

MEP PLANNING MANUAL

(PART – II)

***A Guide to the Project Planning & Installation
related to MEP Works***

PREFACE OF THE FIRST EDITION

This overall methodology for Mechanical, Electrical & Plumbing (MEP) installation in buildings, towers & villa's are include in method statement. This method statement is intended to reflect our understanding of the requirements of the project and the general construction sequences that we will follow. It will provide information of reference documents and equipment required in installation stage.

This MEP method statement has been prepared by HEE professionals and got the approval from the Engineers & the Clients in our previously executed projects. With the help of this method statement it's easy to plan the activity in more professional, technical and smooth manner to maintain the quality of work, safety requirements implementation and time completion.

Each method statement is given unique code number for easy identification i.e.

MS – EL - 01

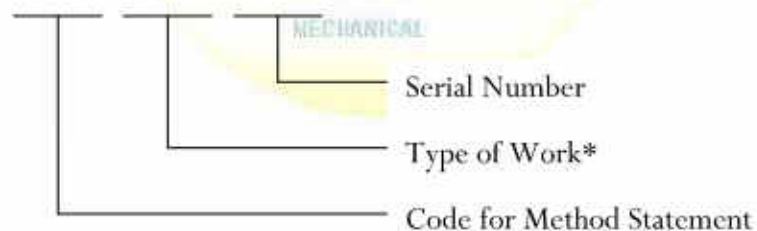

* EL : Electrical

AC : Mechanical – HVAC

PL : Plumbing

FF : Fire Fighting

INTRODUCTION

This Part-II is divided into four sections:-

- Section 9 : Method Statement for Electrical Installation
- Section 10 : Method Statement for Mechanical (HVAC) Installation
- Section 11 : Method Statement for Plumbing Installation
- Section 12 : Method Statement for Fire Fighting Installation

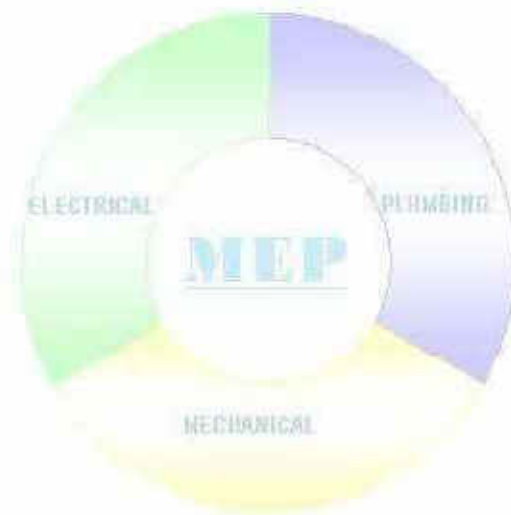

INTRODUCTION

This Part-II is divided into four sections:-

- Section 9 : Method Statement for Electrical Installation
- Section 10 : Method Statement for Mechanical (HVAC) Installation
- Section 11 : Method Statement for Plumbing Installation
- Section 12 : Method Statement for Fire Fighting Installation

Section 9

ELECTRICAL

MEP

MEP

Method Statement for Electrical Installation

Code No. : MS-EL-01

Method Statement

Installation of PVC Conduits Concealed in
Concrete Slab and Columns

MS/EL/01

METHOD STATEMENT FOR INSTALLATION OF PVC CONDUITS IN CONCRETE SLAB & CONCRETE WALLS

SCOPE AND PURPOSE

This method statement covers the site installation of the PVC Conduits in floor slab & concrete wall and the requirements of the checks to be carried out. This procedure defines the method used to ensure that all conduit and associated accessories: bends, tees, couplers, reducers and all accessories associated with systems installed are correct and acceptable.

REFERENCE DOCUMENTS

- Approved Shop Drawings
- Approves Material Submittals

ASSOCIATED WORKS

- Power & Lighting Wiring

RESPONSIBLE PERSONNEL

- Construction Manager
- Project Electrical Engineer
- Site Electrical Engineer
- Site Supervisor
- Technicians Qualified in the trade

METHOD OF PRE INSTALLATION

- Ensure that approved material required to carryout work will be available.
- Prior to commencement of work, area and access will be inspected to confirm that the site is ready to commence the work
- All relevant documentation and material applicable to particular section of works will be checked by site engineer before commencement.
- Physical verification of material will be carried out for any damages prior to taking from stores.
- The site engineer / supervisor will give necessary instruction to tradesman and provide necessary construction / shop drawings.
- The site engineer / supervisor will also check that tools and equipments available are in compliance to contract requirements.
- The site supervisor also explains tradesman regarding safety pre-cautions to be observed.

METHOD OF INSTALLATION

1. Supervisor will ensure that all the grid lines and datum lines are marked by the surveyor and all the route and marking are based on the datum line provided by the surveyor.
2. Supervisor will carryout a site survey and marks the route of conduits as per approved drawings. In the event that there are any discrepancies or difficulties in executing the work, these will be brought to the notice of engineer for corrective action.
3. PVC conduits of correct sizes will be used for concealment of electrical services in the concrete walls & slabs.
4. Cast in conduits are of high impact and of approved make and conform to BS 4607 Part 1, 3 & 5, BS 6099 Parts 1 & 2 and BS 5490.
5. The minimum conduit size used will be 20 mm dia. The conduit size selection is completely as per technical specifications, local statutory authority regulations and as per approved shop drawings.
6. Wherever conduit to be installed in vertical walls the run of conduit will be kept straight,
7. The bending of conduits will be done using proper bending springs and the straight lengths of conduits are coupled using standard couplers glued using good quality PVC sealant.
8. All the cast in conduits will be firmly bended to the steel rebar' and conduits is placed sandwiched between rebars so that future drilling of anchors should not damage cast in conduits and the installed wires.
9. Near DB end conduits are terminated on to thick thermocol placed under concrete so that future alignment of conduit will be easier.
10. Wherever cast in conduits to be terminated on to back boxes standard conduit accessories approved in the material submittal will be used.
11. All the due care will be taken to ensure non blocking of cast in conduits during concreting and contractor's representative will be present at the throughout of concrete period to ensure no conduits gets damaged during casting of concrete slabs.
12. The guide line for conduit size selection will be as per the following table.

Cross Sectional Area of Conductors	Size of Conduit		
	Maximum number of cable drawn		
	20	25	32
1.5 mm ²	7	12	-
2.5 mm ²	5	9	12
4.0 mm ²	3	6	9
6.0 mm ²	-	5	8

QUALITY

- QCE along with Project Engineer and Site Supervisor will monitor that all components are installed as per contract specifications and approved submittals.

- Inspection Request shall be submitted to Consultant after completion of installation of cable tray before pulling of any wires

SAFETY

- Work will commence as per safety regulations laid down in the contract specification and project safety plan.
- Proper safety harness to be used and secured, if required.
- All personal protective equipment shall be used as appropriate according to the nature of job.
- Housekeeping shall be of good standard and all cut lengths and debris shall be removed.



Method Statement
G.I & PVC Conduit on Surface

METHOD STATEMENT FOR G.I. & PVC SURFACE CONDUITING

SCOPE AND PURPOSE

This method statement covers the site installation of the G.I. & PVC Surface Conduiting for small power and lighting and requirements of checks to be carried out.

REFERENCE DOCUMENTS

- Approved Shop Drawings
- Approves Material Submittals
- Approved method statement for wire pulling and earthing.

APPLICABLE LOCATION

- Surface GI Conduiting is generally installed in Electrical rooms and plant rooms, lift motor rooms, substations and outside buildings, partially open ceilings, service areas.
- PVC Conduits are used only the area covered by false ceiling.
- Installation of GI surface conduits shall be done in accordance with the project specifications and drawings.

MATERIALS

- GI conduit and accessories – galvanized conforming to BS 4568 part 1 class 4.
- Metal boxes enclosing electrical accessories conforms to BS 4662.

EQUIPMENT / TOOLS

- Measuring tape
- Drilling machine
- Pipe bending machine
- Threading machine with die-set
- Helical bend springs
- Hammer & Hack saw

RESPONSIBLE PERSONNEL

- QA / QC Engineer
- Project Electrical Engineer
- Site Electrical Engineer
- Site Supervisor

- Electrician
- Helpers

METHOD OF STORAGE

- Conduit shall be lowered not dropped to the ground.
- Conduit shall be given proper support at all times and shall be stacked on flat surface. Manufacturer's instructions shall be followed as applicable.
- Timber support shall be placed at an interval of one meter.
- Conduits shall be protected from direct sunlight and moisture to avoid deterioration.
- Conduits shall be stored with proper end caps.
- Conduits shall be stacked size wise.

METHOD OF PRE INSTALLATION

- Ensure that approved material required to carryout work will be available.
- Proper materials including GI conduits and accessories are with drawn from stores according to approved shop drawing and good engineering practices.
- Physical verification of materials will be carried out for any damages prior to taking from stores and also prior to installation.
- Prior to commencement of work, area and access will be inspected to confirm that site is ready to commence the work.
- All relevant documentation and material applicable to particular section of will be checked by site supervisor prior to commencement of work.
- The site engineer/ site supervisor will give necessary instruction to Electrician and provide necessary approved construction/ shop drawings.
- The site engineer/ site supervisor will also check that proper tools and equipment are available to carry out the work and are in compliance with contract specification
- The site supervisor also explains the electrician regarding safety precautions to be observed.

METHOD OF INSTALLATION

1. Supervisor will carryout a site survey and marks the route of conduit as per approved drawing. In the event that there are any discrepancies of difficulties in executing the work, these will be brought to the notice of project engineer for corrective action.
2. Standard length of conduits shall be cut to the required length.
3. For G.I. conduits threaded shall be done using a threaded machine and correct size die-set. Threaded will be kept to a minimum when showing from coupling and boxes.
4. Cold galvanizing paint is applied to the threaded part of G.I. conduit just before fixing.

5. Where required conduits of size 20mm and 25mm shall be bent to the required radius using manual bending machine. Manufactured bends are used for conduits size 32mm and 50mm.
6. Conduits are fixed to the building fabric by means of distance bars saddle with appropriate metal screws and plugs. A space of 3mm minimum shall be maintained between conduit and the building surface.
7. Check all mechanical connections are internally smooth for pulling wiring in no burrs or sharp edge will be allowed.
8. The route of this steel conduits are restricted to horizontal and vertical runs except for the areas where approved to follow the line of an architecture.
9. Conduit support are fixed in regular interval as mentioned in table:-

Spacing of Conduit Supports

Conduit Size (mm)	Maximum Distance Between Support (M)			
	Rigid Steel		Pliable	
	Horizontal	Vertical	Horizontal	Vertical
20	1.75	2.0	0.4	0.6
25	1.75	2.0	0.4	0.6
32	2.0	2.25	0.6	0.8

10. Ensure the conduit installations are in straight line.
11. Conduits shall be fixed so that no water enters, if it is not practicable a 3mm hole is drilled at the lowest point of the conduit to drain the water out.
12. All terminal boxes are marked on the appropriate location (i.e. wall or ceiling) as per approved shop drawing and fixed with metal screws and plugs. Suitable braze bushes are used where conduit enters the boxes to avoid any damage to the wires.
13. Wherever necessary draw wires shall be pulled into conduit runs and kept at pull boxes for future use.
14. Any rusting of steel conduits occurred during construction shall be removed.

QUALITY

- QCE along with Project Engineer and Site Supervisor will monitor that all components are installed as per contract specifications and approved submittals.
- Inspection Request shall be submitted to Consultant after completion of installation of cable tray before pulling of any wires

SAFETY

- Work will commence as per safety regulations laid down in the contract specification and project safety plan.
- Proper safety harness to be used and secured, if required.
- All personal protective equipment shall be used as appropriate according to the nature of job.

Method Statement
Cable tray & Ladders

EL-03/01/01

MS-EL-03

MS-EL-03

MS-EL-03

METHOD STATEMENT FOR CABLE TRAY & LADDERS

SCOPE AND PURPOSE

This method statement covers the site installation of the cable tray & ladders and requirements of checks to be carried out.

REFERENCE DOCUMENTS

- Approved Shop Drawings
- Approves Material Submittals
- Approved method statement for cable laying and earthing

APPLICABLE LOCATION

- Cable Tray system is generally installed in electrical rooms, plant rooms, service corridors as detailed in approved shop drawings.

MATERIALS

- Cable Trays and associated fittings (Hot dip galvanized conforming to BS 1449 part 1 BS 729)
- Support system (Bracket work, Support Rod, Anchors etc.)

EQUIPMENT / TOOLS

- Drilling machine
- Grinding machine
- Electrician hand tools

RESPONSIBLE PERSONNEL

- Project Electrical Engineer
- Site Electrical Engineer
- QA / QC Engineer
- Site Supervisor
- Electrician & Helpers

METHOD OF STORAGE

- All material received at site shall be inspected and ensure that the material are as per approved material submittal.

- Any discrepancies, damages etc. Shall be notified and reported for further action.
- Materials found not suitable for the project are removed from site immediately.
- Cable tray and ladders are store in horizontal position on flat surface with timber support placed at an interval of one meter and covered to protect from moisture and direct sunlight.

METHOD OF PRE INSTALLATION

- Ensure that approved material required to carryout work will be available.
- Proper materials including cable trays, ladders and associated fittings accessories are with drawn from stores according to approved shop drawing and good engineering practices.
- Physical verification of materials will be carried out for any damages prior to taking from stores and also prior to installation.
- Prior to commencement of work, area and access will be inspected to confirm that site is ready to commence the work.
- All relevant documentation and material applicable to particular section of will be checked by site supervisor prior to commencement of work.
- The site engineer/ site supervisor will give necessary instruction to Electrician and provide necessary approved construction/ shop drawings.
- The site engineer/ site supervisor will also check that proper tools and equipment are available to carry out the work and are in compliance with contract specification
- The site supervisor also explains the electrician regarding safety precautions to be observed.

METHOD OF INSTALLATION

15. After the civil clearance to proceed with MEP installations, ensure the area is clean and ready to start the works.
16. Mark the trays and ladders routes as per approved shop drawing; ensure these are of horizontal & vertical runs only.
17. Co-ordinate the routes, levels and ensure there are no clashes with other services.
18. Maintain enough clearance for cable pulling and any access for future maintenance.
19. Mark the support, fix the threaded rod supports with appropriate metal plugs, and then fix the 'L' angles / Slotted 'C' channels with nuts. A maximum of 1.2 M distance is maintained between the supports to avoid sagging of trays and ladders. Provide adequate supports for bends, branches and offsets.
20. Cut the standard length / ladder to required length with appropriate cutting tools. Use mushroom head screws on the cable route to avoid the cable insulation damage during pulling.
21. All the fittings shall be from manufacturer.
22. Expansion provision shall be provided at all the building expansion joints.
23. Manufacturer's instruction for installation shall be followed.
24. Approved fire sealant shall be provided wherever the installation crosses the fire rated walls.
25. Sleeves shall be provided at all the wall crossing.
26. Copper earth link shall be installed at every joint to maintain continuity throughout the installation.
27. Ensure the installation of tray / ladders are neat, in straight line. Trim the extra projected supports.

28. All sharp edges and burrs shall be cleaned for pulling the cables.
29. Treat the cut & Drilled part with zinc paint rich paint immediately after cutting and before installation.
30. Provide identification labels as specified to identify the service.
31. Inspection shall be offered fro QC verification.
32. The entire installed cable tray to be protected from damages.

QUALITY

- QCE along with Project Engineer and Site Supervisor will monitor that all components are installed as per contract specifications and approved submittals.
- Inspection Request shall be submitted to Consultant after completion of installation of cable tray before pulling of any wires

SAFETY

- Work will commence as per safety regulations laid down in the contract specification and project safety plan.
- Proper safety harness to be used and secured, if required.
- All personal protective equipment shall be used as appropriate according to the nature of job.

Method Statement
Cable Trunking System

REVISION

REVISION

REVISION

REVISION

METHOD STATEMENT FOR CABLE TRUNKING SYSTEM

SCOPE AND PURPOSE

This method statement covers the site installation of the cable trunking system and requirements of checks to be carried out. This procedure defines the method used to ensure that all cable trunking and associated fittings: bends, tees, couplers, reducers, flanges, relevant bracket work, supports rods, anchors and all accessories associated with integrated cable management systems installed are correct and acceptable.

REFERENCE DOCUMENTS

- Approved Shop Drawings
- Approves Material Submittals

EQUIPMENT / TOOLS

- Measuring tape
- Drilling machine
- Grinding machine
- Electrician hand tools

RESPONSIBLE PERSONNEL

- Project Electrical Engineer
- Site Electrical Engineer
- QA / QC Engineer
- Site Supervisor
- Electrician
- Helpers



METHOD OF PRE INSTALLATION

- Ensure that approved material required to carryout work will be available.
- Proper materials including cable trays, ladders and associated fittings accessories are with drawn from stores according to approved shop drawing and good engineering practices.
- Physical verification of materials will be carried out for any damages prior to taking from stores and also prior to installation.
- Prior to commencement of work, area and access will be inspected to confirm that site is ready to commence the work.
- All relevant documentation and material applicable to particular section of will be checked by site supervisor prior to commencement of work.

- The site engineer/ site supervisor will give necessary instruction to Electrician and provide necessary approved construction/ shop drawings.
- The site engineer/ site supervisor will also check that proper tools and equipment are available to carry out the work and are in compliance with contract specification
- The site supervisor also explains the electrician regarding safety precautions to be observed.

METHOD OF INSTALLATION

33. Work will be carried out as per manufacturer's recommendations.
34. Supervisor will carryout a site survey and marks the route of cable trunking as per approved drawings.
35. Dedicated cable trunking of size as approved in the shop drawing will be provided for lighting/ power and extra low voltage (ELV) services.
36. For connection of PVC/GI conduits to GI trunking installation details shown in approved shop drawing will be followed.
37. Cable trunking will be in accordance with BS 4678 Part 1 and made of galvanized steel.
38. Adjoining lengths of trunking will be correctly aligned and the two sides at right angles to the cover will be joined to the corresponding side of the trunking piece by means of an internal fish plate connector.
39. Standard manufacturer's fittings will only be used except when necessitated by site conditions, the consultant engineer's approval will be obtained.
40. All the joints of trunking both at straight lengths or accessories will be fitted with a copper bonding strap and will be secured by screw, nuts and washers. The earth bonding links will be external to trunking and will make good contact with the trunking and continuity will not depend on the contact through screws. Jointing screws will be installed with exposed thread and nut/spring washer external to the trunking.
41. Trunking fixing centers are not to exceed those listed below and only incase of 50x50 trunking there will be a center fixing only. All other sizes will have two fixing at appropriate fixing centers as given below:

Cross Sectional Area of Trunking	Distance between Supports	
	Steel Trunking	
	Horizontal	Vertical
1. Upto 2500 mm ²	1.20 M	1.5 M
2. Above 2500 mm ² and up to 6000 mm ²	1.20 M	1.8 M
3. Above 6000 mm ² and up to 10000 mm ²	2.3 M	2.5 M
4. More than 10000 mm ²	3.0 M	3.0 M

42. All trunking accessory fittings will be secured not more than 150mm from the jointing points.
43. Additional support will be provided if required.

44. Cable tray will be inspected before pulling the wires.
45. Trunking will be installed in such a way that adequate clearance will be provided for access to wiring. Covers will be installed on to the exposed side of trunking. Where trunking installed horizontal plane with lid on to bottom side then conduit connection will be done from top and side.
46. Earth continuity will be available through out the trunking including bends and offsets.
47. Cable trunking crossing the fire rated walls will be provided with fire protection barriers of approved materials according to civil defense regulations and will be by main contractor's scope.
48. Any cuts made to the trunking will be debarred for rough surface and treated with cold galvanized paint.
49. The supervisor in charge and QC inspector will monitor the activities to ensure that all components indicated in the approved construction drawing installed as per the contract requirements and manufacture recommendations.

QUALITY

- QCE along with Project Engineer and Site Supervisor will monitor that all components are installed as per contract specifications and approved submittals.
- Inspection Request shall be submitted to Consultant after completion of installation of cable tray before pulling of any wires

SAFETY

- Work will commence as per safety regulations laid down in the contract specification and project safety plan.
- Proper safety harness to be used and secured, if required.
- All personal protective equipment shall be used as appropriate according to the nature of job.
- Housekeeping shall be of good standard and all cut lengths and debris shall be removed.

Method Statement
Installation of Earthing System

ELECTRICAL

NO. 10

MECHANICAL

METHOD STATEMENT FOR INSTALLATION OF EARTHING SYSTEM

SCOPE AND PURPOSE

This method statement covers the site installation of the Earthing System

REFERENCE DOCUMENTS

- Approved Shop Drawings
- Approves Material Submittals

MATERIAL

- Earth rods, Earth rod clamps, Earth bars and Disconnecting Links

RESPONSIBLE PERSONNEL

- Project Electrical Engineer
- Site Electrical Engineer
- Site Supervisor
- Technicians Qualified in the trade

APPLICABLE LOCATION

- Basement, Ground level, Roof, Mechanical & Electrical rooms at all levels. All mechanical services exposed will be bonded to the earthing system.

METHOD OF PRE INSTALLATION

- Ensure that approved material required to carryout work will be available.
- Prior to commencement of work, area and access will be inspected to confirm that the site is ready to commence the work
- All relevant documentation and material applicable to particular section of works will be checked by site engineer before commencement.
- Physical verification of material will be carried out for any damages prior to taking from stores.
- The site engineer / supervisor will give necessary instruction to tradesman and provide necessary construction / shop drawings.
- The site engineer / supervisor will also check that tools and equipments available are in compliance to contract requirements.
- The site supervisor also explains tradesman regarding safety pre-cautions to be observed.

METHOD OF INSTALLATION

1. As per approved drawing identify location of earth pit.
2. Co-ordinate with civil contractor for installation of earth pits with approved fixing details.
3. The copper earth rod will be driven manually in earth. After achieving a minimum depth of approximate 3 meters, the earth resistance will be measured, If the earth resistance value is not satisfactory, the process of adding further earth electrodes shall be continued till expected resistance value of less than 1 ohm is achieved.
4. Adjacent earth electrodes shall be spread to atleast 1 length of one of the driven electrodes (6 mtrs) to achieve result of less than 1 ohm. Inspection request to be issued.
5. The earth pit shall be installed after completion of installation of earth rods and a clear gap of 50 mm shall be maintained between top of earth electrode and earth pit cover. The top of earth pit shall be in level with the finished floor level in the area.
6. The PVC sheathed single core earthing cables of specified sized as per shop drawing shall be laid between the earth pit and the earth bar inside the building and terminated with approved type lugs/ clamps.
7. The interconnection of earth pit shall be as per approved shop drawing.
8. All earthing connections shall be made after cleaning the surface thoroughly and tightness checks for each connection shall be performed.
9. Continuity of earth connections shall be checked for every link in the network by QA Engineer, Issue Inspection request.
10. The down-stream earthing connections from earth bars shall be made to the panel boards, frames and other equipment as per approved shop drawing.
11. Alongwith all power cables one earth cable of size as per approved shop drawing shall be laid and it shall be terminated to the waarth bat of the panel/ equipment which it feeds, in addition with local earthing from earth bar.
12. On completion of total earthing system and testing, inspection request will be submitted for approval to design consultant.

INSTALLATION OF EQUIPOTENTIAL BONDING

1. The metallic frame of all electrical equipments shall be connected to the nearest earrh bar with a specific size of earth cable.
2. The earthing continuity of cable tray and trunking shall be maintained with earth links on each joints of cable trays and trunking shall be connected to earth bar with specified size of earth cable.
3. Flexible earth cable shall be used for the earthing connections when there is possibility of expansion/ contraction and also where vibrating equipment is installed.
4. The metallic water lines shall be bonded by an earthing cable of size not less than 6mm².
5. All bonding connections shall be checked for correct tightness and cleanliness.
6. Inspection Request will be issued for signature of consultants.

QUALITY CONTROL

- In general, it shall be ensured by site engineer that product manufacturer's recommendations are followed and shall be monitored by QA/QC Engineer. However, the following points shall be ensured, in particular;
 - The appropriate and approved material is used
 - Skilled labor is used for application of the material.
 - Inspection request shall be raised for consultant's inspection.
 - QC inspection shall be carried out as per the installation checklist and manufacturer's instructions.

SAFETY

- Work will commence as per safety regulations laid down in the contract specification and project safety plan.
- Proper safety harness to be used and secured, if required.
- All personal protective equipment shall be used as appropriate according to the nature of job.
- Housekeeping shall be of good standard and all cut lengths and debris shall be removed.

ELECTRICAL

MECHANICAL

MECHANICAL

Method Statement
Installation of Light Protection System

MECHANICAL

METHOD STATEMENT FOR INSTALLATION OF LIGHTNING PROTECTION SYSTEM

SCOPE AND PURPOSE

This method statement covers the site installation of the Lightning Protection System.

REFERENCE DOCUMENTS

- Approved Shop Drawings
- Approves Material Submittals

MATERIAL

- Material used for the system is as per BS 6651 : 1992

RESPONSIBLE PERSONNEL

- Project Electrical Engineer
- Site Electrical Engineer
- Site Supervisor
- Technicians Qualified in the trade

METHOD OF PRE INSTALLATION

- Ensure that approved material required to carryout work will be available.
- Prior to commencement of work, area and access will be inspected to confirm that the site is ready to commence the work
- All relevant documentation and material applicable to particular section of works will be checked by site engineer before commencement.
- Physical verification of material will be carried out for any damages prior to taking from stores.
- The site engineer / supervisor will give necessary instruction to tradesman and provide necessary construction / shop drawings.
- The site engineer / supervisor will also check that tools and equipments available are in compliance to contract requirements.
- The site supervisor also explains tradesman regarding safety pre-cautions to be observed.

METHOD OF INSTALLATION

1. The dedicated rebar is selected from the pile cap and the cable is clamped with the rebar by CR730 clamp and connected to the dedicated rebar of the selected column as per approved shop drawing.

2. Fix G.I. Box 160x80x35 at 500mm from SSL (for testing purpose) on the column. The box shall be tied with reinforcement rod and the box cover will be flush with the finish wall.
3. The dedicated rebars of the column as per shop drawing shall be connected to a 70 sq.mm PVC cable using CR 705 Furuse clamp for the extension till it reaches the roof.
4. Expanded polystyrene shall be applied to seal the hole within the concealed disconnect link box and tied with steel binding wire to prevent concrete / cement entering into the box.
5. Prior to concreting, earth continuity between reinforcement rods and dedicated rods shall be checked with a.d.c. ohm meter.
6. In each tower final test sheet shall be offered to consultant for witness and sign-off.
7. Once rebar has reached up to the height as shown in the drawing for bonding, the work shall be coordinated with Civil Contractor. This is applicable in locations as shown in design drawings.
8. At roof G.I. box 160x80x35mm shall be fixed at 500mm from SSL with fixed of PC116 furuse earth point with pre-welded joint. The box shall be tied with reinforcement rod and box cover shall be flush with finish wall 25x3 copper tape run on roof perimeter as shown in shop drawing bonded with non ferrous bonding point. All mechanical i.e. AHU's , pole structure, petal structure etc. shall be bonded with 25x3 copper tape.
9. 25x3 copper tape shall be fixed on top of parapet wall at 1m intervals as shown in shop drawing with Non-ferrous bonding point.
10. Inspection shall be offered for QC verification in stages.
11. Inspection request shall be raised at least 24 hours in advance for consultant's inspection, prior to concrete pour/ cover-up work.
12. Final inspection shall be carried out collecting all the data from previous inspection requests and finally verified for the anticipated results.

QUALITY CONTROL

- In general, it shall be ensure by site engineer that product manufacturer's recommendations are followed and shall be monitored by QA/QC Engineer. However, the following points shall be ensured, in particular;
 - The appropriate and approved material is used
 - Skilled labor is used for application of the material.
 - Inspection request shall be raised for consultant's inspection.
 - QC inspection shall be carried out as per the installation checklist and manufacture's instructions.

SAFETY

- Work will commence as per safety regulations laid down in the contract specification and project safety plan.
- Proper safety harness to be used and secured, if required.
- All personal protective equipment shall be used as appropriate according to the nature of job.
- Housekeeping shall be of good standard and all cut lengths and debris shall be removed.

Method Statement
Pulling & Testing of Electrical Wires
(Conduits and Trunking)

00000000

METHOD STATEMENT FOR PULLING AND TESTING OF WIRES

SCOPE AND PURPOSE

This method statement covers the on site Pulling and Testing of Electrical wires in PVC/GI conduits and trunking for small power and lighting and the requirement of checks to be carried out.

REFERENCE DOCUMENTS

- Approved Shop Drawings
- Approves method statement for installation of PVC/GI conduits, trunking and earthing
- Authority regulations

GENERAL

Electrical wires shall be enclosed in conduit, trunking and with in short lengths of flexible conduit for final connections to the various items of the equipment. Installation wires will be carried out as per the project specifications and drawings and authority regulations.

MATERIAL

- PVC insulated wires confirming to BS 6004 and IEC-60227 rated at 450/750V
- Heat resisting cables confirming to BS 6007

RESPONSIBLE PERSONNEL

- Project Electrical Engineer
- Site Electrical Engineer
- Site Supervisor
- Technicians Qualified in the trade

METHOD OF PRE INSTALLATION

- Ensure that approved material required to carryout work will be available.
- Prior to commencement of work, area and access will be inspected to confirm that the site is ready to commence the work
- All relevant documentation and material applicable to particular section of works will be checked by site engineer before commencement.
- Physical verification of material will be carried out for any damages prior to taking from stores.
- The site engineer / supervisor will give necessary instruction to tradesman and provide necessary construction / shop drawings.

- The site engineer / supervisor will also check that tools and equipments available are in compliance to contract requirements.
- The site supervisor also explains tradesman regarding safety pre-cautions to be observed.
- The site supervisor and QC engineer will ensure that Calibrated Megger is available at site for testing.

METHOD OF INSTALLATION

1. Where in single core PVC insulated cables are enclosed with in the conduits, care will be taken that no damage will occur to the cables during their installation.

Where conduits is to be installed in damp conditions or out doors rubber sealing gaskets will be installed behind besa/ adaptable box lids.

2. Number of cables to be pulled into the conduit will be as per **TABLE 1 & 2**. The sum of all factors for the cables, as given in **TABLE 1** shall not be greater than the factor for the conduits as given in **TABLE 2**.

TABLE 1 FACTORS FOR SINGLE CORE PVC INSULATED CABLES ENCLOSED IN A CONDUIT

CONDUCTOR SIZE OF CABLES (mm ²)	FACTORS	
	FOR SHORT RUNS	FOR LONG RUNS OR RUNS WITH BENDS
1.5	27	22
2.5	39	30
4.0	58	43
6.0	88	58
10	146	105

TABLE 2 FACTORS FOR THE CONDUITS

Type of run conduit size (mm)		Straight run			Run with 1 bend			Run with 2 bends		
		20	25	32	20	25	32	20	25	32
Length of run	2m	(460)	(800)	(1400)	286	514	900	256	463	818
	3m	460	800	1400	270	487	857	233	422	750
	4m	286	514	900	256	463	818	213	388	692
	5m	278	500	878	244	442	783	196	358	643
	6m	270	487	857	233	422	750	182	333	600
	7m	263	475	837	222	404	720	169	311	563
	8m	256	463	818	213	388	692	159	292	529
	9m	250	452	800	204	373	667	149	275	500
	10m	244	442	783	169	358	643	141	260	474
	11m	238	433	764		-			-	
	12m	233	424	748		-			-	
	13m	228	416	735		-			-	

	14m	223	408	721	-	-
	15m	218	401	708	-	-

- NOTE: 1.** Short run means a straight run not exceeding 3m long. Long run means straight run exceeding 3m long.
2. The conduit factors shown in brackets shall only be used in conjunction with the corresponding cable factors for short runs.
 3. For cables and ro conduits not indicated in Table 1 & 2 the number of cables drawn in to a conduit shall not exceed space factor of 45%.
3. Before pulling wire into cast in conduits, ensure that nylon draw ropes have been installed and the containment system has been found to be clear of any obstruction.
 4. The use of lubricants, grease, graphite or talc will not be used to assist the drawing of cables.
 5. Cables of different circuit categories will not be mixed with in the same conduit.
 6. While preparing cable ends, ensure that conductor stands are not damaged and the strands are twisted together with pliers to ensure neat and firm connection.
 7. While removing the conductor insulation, ensure that no excess exposed conductor shall be left.
 8. Each circuit will incorporate a separate protective conductor selected in accordance with IEEE regulations (TABLE 54 G latest). Earth continuity will be maintained according to authority's regulations.
 9. Final sub circuits will be installed in continuous lengths and no joints will be permitted along the cable run. The final sub circuits will be wired in the loop – in method and all terminations are made will be accessible.
 10. Neutral conductors of lighting will be wired direct to the lighting points and will not pass through switch boxes.
 11. Where PVC insulated sheathed cable enters or exit the trunking system the hole will be lined up with rubber grommets or bushes.
 12. Where cables are enclosed in the same trunking and connected to different distribution boards, they shall be distinguished by separating the cables by insulating taping at an approximate interval of 2.0M and also with an identification labeling indicating circuit type and reference.
 13. Color identification sleeve to denote phase, circuit reference and/or terminal reference and/or terminal number to which it is connected coding of wires will be followed.

QUALITY CONTROL

- In general, it shall be ensure by site engineer that product manufacturer's recommendations are followed and shall be monitored by QA/QC Engineer. However, the following points shall be ensured, in particular;
 - The appropriate and approved material is used
 - Skilled labor is used for application of the material.
 - Inspection request shall be raised for consultant's inspection.
 - QC inspection shall be carried out as per the installation checklist and manufacture's instructions.

SAFETY

- Work will commence as per safety regulations laid down in the contract specification and project safety plan.
- Proper safety harness to be used and secured, if required.
- All personal protective equipment shall be used as appropriate according to the nature of job.
- Housekeeping shall be of good standard and all cut lengths and debris shall be removed.



Method Statement
Commissioning Management

15/01/2013

METHOD STATEMENT FOR COMMISSIONING MANAGEMENT

SCOPE AND PURPOSE

This "Method Statement" describes the methodology regarding planning, organizing and executing, methods to be adopted for Commissioning Management and Verification of MEP services installed at Jumeirah Beach Residence-Sector 4-A Specialist Commissioning validation (duly approved by the consultant) to be appointed to monitor, witness and verify all testing and commissioning of the MEP services.

REFERENCE DOCUMENTS

- Project Specifications Volume III, Division 15, Section: 15010,15100,15400,16005,16010,16050
- Approved shop drawings (latest revision)
- Approved material submittals
- Local authority regulations (DEWA, CIVIL DEFENCE, etc.)

GENERAL

The MEP Services that will be subjected to Commissioning management and validation procedures include the following:

- Chilled water supply and return systems
- Air conditioning and ventilation systems
- Car park Ventilation Systems
- Domestic water supply system
- Firefighting sprinkler & FM 200 extinguisher systems
- LV Power & Small power
- Emergency lighting & control systems
- Fire detection and alarm system
- Intercom system
- Diesel Generator
- BMS & Controls
- Intercom System

MATERIAL

Approved submittals for

- Specialist for testing and commissioning.
- Approved method statements for commissioning.

EQUIPMENT

Calibrated Inspection, Measuring and Test Equipment as outlined in Method Statements.

RESPONSIBLE PERSONNEL

- Specialist Commissioning Team
- Project Engineers (HVAC/ELEC./PLUMBING)
- Manufacturer's authorized representatives(where required)
- Construction In-Charge.
- Site Engineer/Site supervisor.

- QA/QC Inspectors.
- Safety officer
- Site Foremen.
- Tradesmen
- Helpers

COMMISSIONING MANAGEMENT

OVERVIEW OF COMMISSIONING

RESPONSIBILITY:-

1. MEP contractor shall submit prequalification documents for Commissioning Management and Verification to the Consultant for approval.
2. Upon approval of a Specialist Commissioning Company, regular site meetings will be convened, in order to ensure that commissioning of each element proceeds in a logical, systematic and cost effective manner from commissioning design appraisal through installation, site testing, commissioning performance verification, whilst critically satisfying the requirements of overall project programme.
3. Site Meetings, should discuss the following clearly defined activities:
 - Design Commission ability Review
 - Commissioning Method Statements
 - Commissioning logic diagrams and Programmes.
 - Format of final record documentation.
 - Construction installation appraisal and progress assessment.
 - Progress on Pre-commissioning verification
 - Progress on verification of all commissioning works
 - Verification of integrated performance testing.
 - Review of record documentation
 - Test documentation collation.
4. It will be ensured that Specialist Commissioning project team will be experienced enough to carryout commissioning verification activities.
5. Prior to any commissioning and testing taking place, it is essential that a detailed and flexible commissioning plan be available. The initial aim of this stage of works will be to ensure that all necessary provisions have been made in the construction design to allow commissioning to be completed to the requirements of the specification and within the confines of the construction programme.
6. Upon appointment of a specialist commissioning agency, a detailed report will be produced indicating the following:
 - The equipment and system facilities required.
 - The on-site testing procedures required.
 - Testing and commissioning risk assessments.
 - The handover procedures and final witnessing requirements.

COMMISSIONING PLAN

1. Working method statements for each element of the pre-commissioning, commissioning and performance testing will be made available and submitted to the Consultant for approval during planning phase, prior

to the commencement of any testing. A commissioning Management and Verification matrix is attached and will be followed for this purpose.

2. For Progress monitoring purposes a Commissioning programme will be developed and submitted.
3. Throughout the construction period of the project, the specialist commissioning team will undertake detailed appraisals of the installations, to ensure that the systems contain all necessary features that are required for commissioning and performance of the systems, as well as health and safety considerations for those carryout the commissioning works.

COMMISSIONING PHASE

1. During pre-commissioning and commissioning stages of the project the role of specialist commissioning team is out lined as follows:
2. Ensuring that all necessary pre-commissioning has been carried out to the agreed methods and standards, and is approved by the verification team. This must be completed prior to the start up of all plant and equipment
3. Ensuring that the commissioning and testing works are carried out in accordance with agreed methods and standards as per the commissioning plan.
4. Verifying and collating record documentation for all commissioning and testing operations.
5. Reporting / liasing to ensure that commissioning progress is incorporated into overall completion monitoring process and handover.
6. Commissioning Verification system will require specialist-commissioning contractor to ensure that all tests offered for demonstration have been completed successfully and full documentation is available fully.

COMMISSIONING, TESTING AND VERIFICATION

Following clause describes the main elements of test validation PE/CME witnessing to be undertaken.

CHILLED WATER SYSTEM

- Flushing and chemical cleaning
- Pre-commissioning
- Commissioning of Pumps
- Water balancing

AIR CONDITIONING AND VENTILLATION

- Pre-commissioning.
- Air Balancing (distribution balancing)
- Performance and function testing of AHD's
- Performance and function testing of Fans.
- Performance and function testing of Car Park Ventilation system

PLUMBING SERVICES

- Pre-commissioning
- Plant and function performance (Verify Statutory acceptance)

FIRE FIGHTING SPRINKLER AND FM 200 SYSTEM

- Plant function and performance
- Alarms & monitoring interfaces

LV DISTRIBUTION AND SMALL POWER

- Installation test (Include Meggering)
- Commissioning tests (Verification of switching control and indication)
- Performance testing (verify statutory acceptance)

FIRE ALARM SYSTEM

- Device address and operation tests
- Performance testing (verify overall cause and effect testing)- Civil Defence approval required

MISCEEOUS ELECTRICAL SERVICES

- Air craft warning system (by nominated specialist contractor by client)
- Intercom system
- Telecom / Data system
- Diesel Generator
- Emergency lighting (verify function and statutory demonstrations).
- Earthing / bonding & lightning protection (static verification).
- Security system (by nominated specialist sub contractor by client).
- Swimming pools

BMS AND CONTROLS

- Wiring and panel installation tests
- Commissioning tests (Final function and software graphics).
- Performance testing (overall emergency and plant performance).

HANDOVER PHASE

Client and Statutory Demonstrations

Upon satisfactory completion of commissioning of a particular system or sub-system, the Specialist Commissioning Team will issue the relevant test documentation to the MEP Contractor for onward issue to the consultant and statutory authority as necessary.

COMMISSIONING AND TEST DOCUMENTATION

The Specialist commissioning agency/ Equipment supplier will provide test pro-forma for all site wide operations including pre-commissioning, balancing and testing of air and water systems, and testing of electrical distribution system. The same will be submitted along with method statements.

Following successful witness, the final approved commissioning documentation, as approved by the specialist-commissioning agency, will be collated and submitted to main contractor for onward submission to consultant.

MEP contractor for incorporation into final project O & M manuals will retain a copy of it.

MEETINGS REPORTING AND QUALITY MONITORING SYSTEM

MEETINGS

The following meetings would form part of the specialist commissioning team role throughout the course of works on site: -

- Site progress meetings- if requested by job clients for coordination purposes.
- Commissioning meetings-attended by in-charge Specialist commissioning team.

REPORTING

Monthly progress report shall be prepared by the Specialist commissioning agency in addition to individual work tests, performance demonstrations etc.: -

Detailed elemental report on progress.
Updated commissioning activity schedule.

QUALITY MONITORING SYSTEM

The Specialist commissioning team in association with MEP contractor will provide a detailed breakdown of each element of commissioning for each service. A database will be maintained, showing the status of testing and commissioning process, giving all levels of site management a clear and concise breakdown status.

Specialist commissioning team, for comments on site installation and testing will provide site observation reports.

Testing and commissioning documentation will be compiled monitored in generated database format.

Method Statement
BUS BAR TRUNKING SYSTEM

1. OBJECTIVE

2. SCOPE

3. METHOD

METHOD STATEMENT FOR BUS BAR TRUNKING SYSTEM

SCOPE AND PURPOSE

This "Method Statement" covers the on site installation and testing of Bus bar Trunking systems with relevant accessories and the requirements of checks to be carried out.

REFERENCE DOCUMENTS

- Project Specifications Volume III, Division 16, Section: 16010, 16050, 16477
- Approved shop drawings (latest revision)
- Approved material submittals
- Manufacturer's installation instruction
- Local authority regulations (DEWA, CIVIL DEFENCE, etc.)

GENERAL

Bus - bar trunking system generally includes standard straight lengths, special straight lengths (wherever necessary), elbows (vertical and horizontal), offsets, T -joints, standard component tap off boxes, feeder boxes, fixing elements, flanges, support systems and end connections etc; various items of the equipment. Installation of bus ducts will be carried out as per the project specifications and drawings and DEWA regulations.

EQUIPMENT

- Electrician hand tools
- Torque wrenches
- Scaffoldings
- Nylon slings
- Measuring Tape
- Calibrated Megger

RESPONSIBLE PERSONNEL

- Project Engineers
- Construction In-Charge.
- Site Engineer/Site supervisor.
- QA/QC Inspectors.
- Safety officer
- Site Foremen.
- Tradesmen
- Helpers

METHOD OF PRE INSTALLATION

- Ensure that approved material required to carryout work will be available.
- Bus bars complete with accessories received at site will be inspected as per approved material submittal and manufacturer's approved isometric drawings for completeness and physical damages if any. In case of any damage, the same should be brought to the notice of supplier for suitable resolution/replacement.

- Physical verification of materials will be carried out for any damages prior to taking from stores and also prior to installation. Manufacturer's test certificates received will be reviewed and submitted to consultant for approval.
- Prior to commencement of work, area and access will be inspected to confirm that the site is ready to commence the work
- All relevant documentation and material applicable to particular section of works will be checked by site engineer before commencement.
- Physical verification of material will be carried out for any damages prior to taking from stores.
- The site engineer / supervisor will give necessary instruction to tradesman and provide necessary construction / shop drawings.
- The site engineer / supervisor will also check that tools and equipments available are in compliance to contract requirements.
- The site supervisor also explains tradesman regarding safety pre-cautions to be observed.

METHOD OF INSTALLATION

1. Bus bar installation will be carried out as per approved bus bar lay out/isometric drawings. Before starting the installation of bus bar system, proper co ordination shall be done with other trades.
2. Manufacturer's installation instructions attached will be followed for handling, storage, installations and testing.
3. Determine the position of the bus bar supports as per approved construction drawings and mark them on concrete surfaces.
4. Fix the support as per manufacturer's installation instructions.
5. Provide sufficient horizontal and vertical clearance from walls and ceilings to provide easy access to joints, both for permanent installation and possible future removal of section when required.
6. For vertical bus bars, ensure that no joints or expansion joints are installed in the slab thickness.
7. Bus bar will be leveled and mounted at the correct height.
8. Elbows, offset and tap off boxes etc., will be installed as per approved construction drawings and as per manufacturer's instructions.
9. Cable gland plates for tap off boxes and fixing elements shall be installed as per the recommendations of the Manufacturer and as per approved schematics.
10. Cable gland plates for tap off boxes and fixing elements shall be installed as per the recommendations of the Manufacturer and as per approved schematics.
11. Bus bar should be installed so that the orientations of phase from the front side will be GRY&N. The cabling from tap off shall be from side or bottom.

JOINT ASSEMBLY

12. Ensure that all contact surfaces are clean and free of containments.
13. Align the bus bar ends of adjoining sections, verifying proper phase alignment, and slide the sections together (use joints pullers, if required).

14. Expansion joints if required as shown in approved construction drawings will be installed as manufacturer's instructions attached.
15. After completing the jointing of assemblies, torque the joints bolts to the specific value.
16. Where a bus bar extends through a inside block. Shear walls, an internal transverse barrier supplied by manufacturer will be installed.
17. Bus ways to be properly covered during the installation to protect them from moisture or other types of contaminants.
18. All the floor/wall crossing of bus bars is to sealed with approved type of fire sealant.
19. Bus bar enclosure continuity shall be ensured with proper bounding and connected to the main earthing grid through return paths al LV Panel end.

TESTING

After complete installation of Bus bar systems, Bus bars are subjected to following tests as recommended by Manufacturer:

- Checking of all joint connections for tightness.
- An Insulation Resistance test, carried out with a calibrated Megger insulation tester, to ensure that system is free from short circuits and grounds (phase-to-ground, phase -to- neutral and phase-to-phase). It should be noted that readings vary inversely with the length of run and width or number of bars per phase.
- Verify that system phasing matches the busway phasing before reconnecting all connections to switchboards.
- Continuity tester will be used to check electrical continuity of SS/QCE phase bus bars, neutral bus bar and earth bus bar.

QUALITY CONTROL

- QCE along with Project Engineer and site Supervisor will monitor that all components are installed as per the contract specifications and approved submittals.
- Inspection Request (IR) shall be submitted to the Main PE/SS/QCE Contractor/Consultant during the following stages :-
- After completion of installation of bus ducts for a particular area/section.
- For testing of Bus ducts.

SAFETY

- Work will commence as per safety regulations laid down in the contract specification and project safety plan.
- Proper safety harness to be used and secured, if required.
- All personal protective equipment shall be used as appropriate according to the nature of job.
- Housekeeping shall be of good standard and all cut lengths and debris shall be removed.
- Hoisting and handling of bus ducts will be carried out as per manufacturer's installations.

Method Statement
Building Management System

METHOD STATEMENT FOR BUILDING MANAGEMENT SYSTEM

SCOPE AND PURPOSE

This method statement covers the site wiring, termination and commissioning of Building management system installed.

REFERENCE DOCUMENTS

- Approved Shop Drawings
- Approves Material Submittals

GENERAL

The work station controls/ monitor equipments such as Pumps, AHD's / FCU's etc; through cable network, FCU/DDC controllers and various peripheral instruments installed in the system as per approved layouts.

EQUIPMENT / TOOLS

- Calibrated Megger
- Calibrated Multi meter
- Operator terminal (PXM20)
- Electrician hand tools
- Lap top computer

RESPONSIBLE PERSONNEL

- Commissioning Engineer
- Project Electrical Engineer
- Site Electrical Engineer
- QA / QC Engineer
- Site Supervisor
- Electrician
- Helpers

PROCEDURE

Wiring, termination and pre-commissioning procedures:

1. Ensure that locations all Peripheral devices installed in various systems are as per approved layout drawings and suitable for system operation logics.

2. Ensure that installations of DDC panel/FCU Controllers are complete and are acceptable.
3. Ensure that all cable containment and cabling is completed as per approved drawings and As-Built marked up drawings are available reflecting the actual site installations.
4. Siemens will be notified, when the installations are complete to ensure that installations are acceptable.
5. Terminations to DDC panels/ FCU controllers will be carried out as per latest approved drawings and documents.
6. Continuity checks for wiring (for DDC/FCU loops) will be carried and the same are acceptable.
7. Prior to Commencement of Commissioning, areas and access will be inspected to confirm that Site is ready to commence the commissioning.
8. Ensure that all instruments are calibrated and are in proper working condition.

Method of Commissioning

1. Commissioning of Building management system will be carried out as per SIEMENS Method statements attached.
 - MS001- Wiring and termination of DDC Panels
 - MS002- Wiring and termination of LON FCU Controllers
 - MS003- Commissioning of Outstation panels(DDC Panel)
 - MS004- Commissioning of FCU Controller
 - MS005- Commissioning of Central interface panel & BMS Management station.
2. All the test documentation will be recorded on the test sheets attached to the above Siemens Procedures attached.

QUALITY

- QCE in coordination with Commissioning Manager and SIEMENS Engineer notify to Consultants for Wire termination and continuity checks for each building/area.
- QCE in coordination with Commissioning Manager and SIEMENS Engineer notify to Consultants for commissioning of DDC outstation panel, FCU Controller and Central inter face panel & BMS management station.
- QCE in association with Commissioning Manager and Project Engineer will ensure that all the test documentation is complete and signed off.

SAFETY

- Work will commence as per safety regulations laid down in the contract specification and project safety plan.
- Proper safety harness to be used and secured, if required.
- All personal protective equipment shall be used as appropriate according to the nature of job.
- Housekeeping shall be of good standard and all cut lengths and debris shall be removed.

ATTACHMENTS

SIEMENS METHOD STATEMENT FOR BUILDING MANAGEMENT SYSTEM ALONG WITH TYPICAL CHECKLIST ATTACHED.



Section 10

**Method Statement for Mechanical (HVAC)
Installation**

REVISED

Method Statement
Installation of HVAC Ductwork

1.0 INTRODUCTION

2.0 REFERENCES

METHOD STATEMENT FOR INSTALLATION OF HVAC DUCTWORK

SCOPE AND PURPOSE

This "Method Statement" covers the on site installation of HVAC duct work and accessories and the requirement of checks to be carried out.

REFERENCE DOCUMENTS

- Project Specifications
- Approved shop drawings (latest revision)
- Approved material submittals
- Duct work standard DW 144

GENERAL

HVAC duct work generally includes all types of Supply Air Duct, Return Air Duct, Fresh and Exhaust Air Duct and their accessories such as duct elbows, offsets, transformation pieces branch off pieces, tee connections, access doors, Fire Dampers, Volume Control Dampers, Sound Attenuators, flexible ducting and insulation.

EQUIPMENT

- Portable grinding Machine
- Drilling Machine
- Sheet metal cutting tools and bender
- Spirit level
- Scaffolding
- Duct erector hand tools
- Testing instruments
- Air Compressor

RESPONSIBLE PERSONNEL

- Project Engineers
- Construction In-Charge.
- Site Engineer/Site supervisor.
- QA/QC Inspectors.
- Safety officer
- Site Foremen.
- Pipe fitters / Welders
- Helpers

METHOD OF PRE INSTALLATION

- Ensure that approved material required to carryout work will be available.

- Prior to commencement of work, area and access will be inspected to confirm that the site is ready to commence the work
- All relevant documentation and material applicable to particular section of works will be checked by site engineer before commencement.
- Physical verification of material will be carried out for any damages prior to taking from stores.
- The site engineer / supervisor will give necessary instruction to tradesman and provide necessary construction / shop drawings.
- The site engineer / supervisor will also check that tools and equipments available are in compliance to contract requirements.
- The site supervisor also explains tradesman regarding safety pre-cautions to be observed.
- Prior to Leak testing, Site Engineer will ensure that Calibrated test kit is available and are in good condition.

METHOD OF INSTALLATION

1. Prior to commencement of work coordination will be done with other
2. Determine the position of duct supports as per approved construction layouts and specification.
3. Prepare and fix the duct supports as per approved construction drawing and specification.
4. Any cut edges of angles, channels or threaded rods will be touch up with Zinc rich paint.
5. Transport the Duct pieces and fittings to final location.
6. Pre-assemble the Duct pieces " and ' fittings as per approved shop drawing ensuring the alignment.
7. Acoustic insulation will be carried out wherever required.
8. Raise the duct work on to the supports ensuring that each length is aligned with preceding length as per dimensions shown on approved shop drawings.
9. Approved duct sealant shall be applied on the joints. Any excess sealant so that the joint left in clean and tidy condition.
10. Ensure that duct work is clean and no tools/ construction debris exists within duct work before proceeding to next length.
11. All open ends of the duct works shall be temporarily sealed with polythene sheets/ply wood before leaving the job site to prevent moisture and dirt.
12. Ensure that all accessories like Volume control dampers, Fire dampers, Access doors, Test points, Sensors are installed in accordance with approved shop drawings.
13. Install Sound Attenuators according to approved shop drawings
14. Installation of duct work (complete with accessories) shall be checked before applying insulation at joints.
15. Leak test will be carried out for duct work as applicable in DW144 standard.
16. Insulation of duct work will be completed as per manufacturer's recommendations (copy-enclosed).
17. Ensure the duct surface is clean and dry before applying any insulation material.
18. Ensure the thickness of insulation as per approved shop drawing.

19. Ensure that all edge joints are closely butted and ends are flush and seated properly.
20. Apply ALUGLASS Tape (Self Adhesive Aluminium Foil Laminated on Glass fabric) at Joints of insulation.
21. Ensure the continuity of vapor barrier and other protective coatings on insulation surface as well as at connections.
22. Ensure firm adherence of insulation around_ ducting by using approved adhesive between sheet metal and Insulation material.
23. Where insulated duct work passes through fire rated wall/partitions the gap between sleeve and duct work shall be filled with approved fire barrier.

QUALITY CONTROL

- QCE along with Project Engineer and site Supervisor will monitor that all components are installed as per the contract specifications and approved submittals.
- Inspection Request (IR) shall be submitted to the Main Contractor/Consultant during the following stages :-
 - After completion of installation before testing
 - Leak testing of duct work
 - After complete insulation

SAFETY

- Work will commence as per safety regulations laid down in the contract specification and project safety plan.
- Proper safety harness to be used and secured, if required.
- All personal protective equipment shall be used as appropriate according to the nature of job.
- Housekeeping shall be of good standard and all cut lengths and debris shall be removed.
- Good ventilation for duct work insulation shall be ensured.

Method Statement
Installation and insulation of Spiral Round
Ducting and Duct Accessories

MS-AC-02

METHOD STATEMENT FOR INSTALLATION AND INSULATION OF SPIRAL ROUND DUCTING AND DUCT ACCESSORIES

SCOPE AND PURPOSE

This "Method Statement" covers the on site installation of Spiral round ducting and duct accessories and the requirement of checks to be carried out.

REFERENCE DOCUMENTS

- Project Specifications
- Approved shop drawings (latest revision)
- Approved material submittals
- Duct work standard DW 144

GENERAL

GI Spiral round ducting generally installed in for FCU return air, and supply air as shown in approved shop drawing includes spiral round ducting, fittings such as elbows, tees, couplings, reducers, collars etc, volume control dampers, flexible ducting insulation.

EQUIPMENT

- Portable grinding Machine
- Drilling Machine
- Sheet metal cutting tools and bender
- Spirit level
- Scaffolding
- Duct erector hand tools
- Testing instruments
- Air Compressor



RESPONSIBLE PERSONNEL

- Project Engineers
- Construction In-Charge.
- Site Engineer/Site supervisor.
- QA/QC Inspectors.
- Safety officer
- Site Foremen.
- Pipe fitters / Welders
- Helpers

METHOD OF PRE INSTALLATION

- Ensure that approved material required to carryout work will be available.

- Prior to commencement of work, area and access will be inspected to confirm that the site is ready to commence the work
- Check all the GI Spiral ducting received are pre fabricated with tag number labeled and received at site in accordance with specifications and correct dimensions as per approved drawings.
- All relevant documentation and material applicable to particular section of works will be checked by site engineer before commencement.
- Physical verification of material will be carried out for any damages prior to taking from stores.
- The site engineer / supervisor will give necessary instruction to tradesman and provide necessary construction / shop drawings.
- The site engineer / supervisor will also check that tools and equipments available are in compliance to contract requirements.
- The site supervisor also explains tradesman regarding safety pre-cautions to be observed.

METHOD OF INSTALLATION

1. Prior to commencement of work coordination will be done with other services.
2. Determine the position of duct supports as per approved Shop drawings and coordinated layouts and specification.
3. Prepare and fix the duct supports as per approved construction drawing and specification.
4. Any cut edges of angles, channels or threaded rods will be touch up with Zinc rich paint.
5. Transport the duct pieces and fittings to final location.
6. Before assembly ensure that all ducts are free from dirt.
7. Check that ducts and fittings are undamaged. This is specially important with regard to the rubber gaskets.
8. Assemble the Duct pieces and fittings as per approved shop drawing ensuring the alignment.
 - a) Push the fittings into the duct right to the stop. Turning the fitting a little makes insertion easier.
 - b) Fasten fittings to the duct with self tapping screws or centered pop rivets.
 - c) Distribute the screws or pop rivets evenly around the circumference, ensuring the rubber gaskets are not damaged i.e. placing the them approx.10mm from stop and end of the duct. In the event of incorrect assembly, holes caused by screws or pop rivets must be sealed.
9. Raise the duct work on to the supports ensuring that each length is aligned and leveled with preceding length as per dimensions shown on approved shop drawings.
10. Ensure that duct work is clean and no tools/ construction debris exists within duct work before proceeding to next length.
11. All open ends of the duct works shall be temporarily sealed with polythene Sheets/ply wood before leaving the job site to prevent moisture and dirt.
12. Ensure that all accessories like Volume control dampers, Test points, Sensors are installed in accordance with approved shop drawings.
13. Installation of duct work (complete with accessories) shall be checked before applying insulation at joints.
14. Insulation of duct work will be completed as per manufacturer's recommendations (copy enclosed).

- a) Ensure the duct surface is clean and dry before applying any insulation material. Apply thinner /cleaner where necessary to make the area grease free.
 - b) Apply glue recommended by manufacturer with an even spread on complete surface of insulation sheet.
 - c) Once the glue on the sheet gets dry, apply glue on the GI duct and let it dry, then stick the sheet on one end and slowly press the sheet on the duct from one end to the other so as to ensure that the sheet sticks on the GI duct completely avoiding air bubbles between the insulation sheet and GI duct.
 - d) In the areas where the GI duct comes into contact with the duct hangers, rigid support is recommended such as wood. The wood piece should be glued onto the duct hanger and layer of rubber to be glued on the wood, so that there is no direct contact between the duct insulation and the wooden piece thus preventing tearing of the duct insulation. In case the positioning of the support is available in advance, wood by itself can be used. In this case it has to be made sure that insulation will be glued to the wood from both sides accordingly.
15. Where insulated duct work passes through fire rated wall/partitions the gap between sleeve and duct work shall be filled with approved fire barrier.

QUALITY CONTROL

QCE along with Project Engineer and site Supervisor will monitor that all components are installed as per the contract specifications and approved submittals.

- Inspection Request (IR) shall be submitted to the Main Contractor/Consultant during the following stages :-
- Mock up installation of GI spiral round ducting before and after insulation
- After complete insulation

SAFETY

- Work will commence as per safety regulations laid down in the contract specification and project safety plan.
- Proper safety harness to be used and secured, if required.
- All personal protective equipment shall be used as appropriate according to the nature of job.
- Housekeeping shall be of good standard and all cut lengths and debris shall be removed.

Method Statement
Installation, Testing & Insulation of Chilled
Water System

REVISIONS

METHOD STATEMENT FOR INSTALLATION, TESTING & INSULATION OF CHILLED WATER SYSTEM

SCOPE AND PURPOSE

This "Method Statement" covers the on site installation, testing and insulation of the chilled water piping system including risers and the requirements of checks to be carried out.

REFERENCE DOCUMENTS

- Project Specifications
- Approved shop drawings (latest revision)
- Approved material submittals

GENERAL

Chilled water piping system includes chilled water pipes, fittings, valves and accessories used for transportation (supply and return) chilled water for AHU's and FCU's through Chilled water pumps. Pipes and fittings up to 50 NB dia. size shall be threaded type and 65 NB and above shall be either grooved or welded type.

EQUIPMENT

- Electrical grinding Machine
- Scaffolding
- Drilling Machine
- Ladders
- Heavy duty cutter.
- Pipe fitter hand tools
- Grooving machine
- Electrode oven/ Quivers
- Threading machine
- Pressure test pump
- Welding machine
- Test pressure gauges
- Cutting Torch set.

RESPONSIBLE PERSONNEL

- Project Engineers
- Construction In-Charge.
- Site Engineer/Site supervisor.
- QA/QC Inspectors.
- Safety officer
- Site Foremen.
- Pipe fitters / Welders
- Helpers

METHOD OF PRE INSTALLATION

- Ensure that approved material required to carryout work will be available.

- Proper materials including chilled water pipes, fittings and associated accessories are with drawn from stores according to approved shop drawing and good engineering practices.
- Prior to commencement of work, area and access will be inspected to confirm that the site is ready to commence the work
- All relevant documentation and material applicable to particular section of works will be checked by site engineer before commencement.
- Physical verification of material will be carried out for any damages prior to taking from stores.
- The site engineer / supervisor will give necessary instruction to tradesman and provide necessary construction / shop drawings.
- The site engineer / supervisor will also check that tools and equipments available are in compliance to contract requirements.
- The site supervisor also explains tradesman regarding safety pre-cautions to be observed.
- Prior to Hydrostatic Pressure testing, Site Engineer will ensure that Calibrated pressure gauges are available and are in good condition

METHOD OF INSTALLATION

1. All welding activities will be carried out by certified welders only.
2. Supervisor/Foremen will carryout a site survey and mark the route of Chilled water piping as per approved shop drawings. In the event that there are any discrepancies or difficulties in executing the work, these will be brought to the notice of Project Engineer for corrective action.
3. Determine the position of supports and fix the supports using anchor bolts and ensure all fixing are tight and secure.
4. Any cut edges of angles, channels or threaded rods will be touch up with Zinc rich paint.
5. Install the pipes in position by using suitable lifting equipments(If necessary).
6. Assemble the pipes and fittings as per approved shop drawing.
7. After installation of pipe work check for correct leveling, position alignment and proper grooving/threading or welding.
8. Where the pipes of dissimilar materials are to be joined together necessary; dielectric unions shall be used.
9. Sufficient spacing shall be maintained between pipes for insulation.
10. Spacing between supports / hangers will be maintained in accordance with latest approved shop drawings.
11. Ensure all open ends of pipes, fittings and valves are covered with polyethylene sheet before leaving work space.
12. All high point on piping system will be provided with an air vent. Drains ; will be provided at low point with an access. High point vents will be connected nearest drains.

13. INSTALLATION OF VALVES AND ACCESSORIES

- Install system valves and accessories as per latest approved shop drawings.
- Ensure that system equipment, valves and accessories are secure and rigid

- The installation shall be done allowing sufficient access to all Valves/strainers/Gauges as per Manufacturer's recommendations.

14. INSTALLATION OF CHILLED WATER RISERS

- Pipe sizes will be identified first as per latest approved shop drawing and shifted to respective floors.
- Install the supports as per approved shop drawing.
- The pipe shall be thoroughly cleaned prior to joining.
- On completion of joining, install the pipes using necessary equipment / manpower.
- After installation of risers check the pipeline for proper alignment and supports.

HYDROSTATIC PRESSURE TESTING

1. Complete pipe work will be subjected to hydraulic pressure tested as per technical specification. Depending on ongoing Construction activities sectional hydro testing will be under taken to meet the requirements of the programme. Test pressure will not be less than 1.5 times the working pressures but not less than 1035 KPa (for 24 hour period) which ever is greater. Prior to any testing the system pressure will be detailed on the pressure testing documentation.
2. Pressure gauges used for Pressure testing will have valid calibration certificate.
3. After successful Pressure testing ensure that piping system is fully drained and released for chemical cleaning which will be carried out at later date as per approved method statement

INSULATION

1. Before application of thermal insulation, Chilled water pipes will be ; painted with a primer paint as per specification. Painting of welded joints will be carried out after pressure testing.
2. Insulation of chilled water pipe work will be carried out as per details as shown in approved submittals. Thermal insulation of welded joints will be carried out after pressure testing.
3. Ensure thickness of insulation is as per approved drawing

QUALITY CONTROL

- QCE along with Project Engineer and site Supervisor will monitor that all components are installed as per the contract specifications and approved submittals.
- Inspection Request (IR) shall be submitted to the Main Contractor/Consultant during the following stages :-
- After completion of installation before hydrostatic pressure test.
- Pressure testing of piping
- After completion of insulation

SAFETY

- Work will commence as per safety regulations laid down in the contract specification and project safety plan.
- Proper safety harness to be used and secured, if required.
- All personal protective equipment shall be used as appropriate according to the nature of job.
- Housekeeping shall be of good standard and all cut lengths and debris shall be removed.
- Fire Extinguishers will be provided in the near vicinity during welding and cutting operations.
- Where ever required fire blanket will be provided.
- Hot work permit system will be followed.



Method Statement
Installation of Fan Coil Unit (FCU)

SYNOPSIS

OBJECTIVE

SCOPE OF WORK

REFERENCES

METHOD STATEMENT FOR INSTALLATION OF FAN COIL UNIT

SCOPE AND PURPOSE

This "Method Statement" covers the on site installation of FAN COIL UNITS (FCU) and the requirements of checks to be carried out.

REFERENCE DOCUMENTS

- Project Specifications
- Approved shop drawings (latest revision)
- Approved material submittals

GENERAL

Fan Coil Units generally be installed in locations shown in drawings, serving apartments mechanical -rooms etc.-; both in concealed areas and exposed supplying cold dehumidified air conditioned space.

EQUIPMENT

- Drilling Machine
- Spirit Level
- Scaffolding
- Hand tools of Trads men

RESPONSIBLE PERSONNEL

- Project Engineers
- Construction In-Charge.
- Site Engineer/Site supervisor.
- QA/QC Inspectors.
- Safety officer
- Site Foremen.
- Pipe fitters
- Helpers

METHOD OF PRE INSTALLATION

- Ensure that approved material required to carryout work will be available.
- Prior to commencement of work, area and access will be inspected to confirm that the site is ready to commence the work
- All relevant documentation and material applicable to particular section of works will be checked by site engineer before commencement.
- Physical verification of material will be carried out for any damages prior to taking from stores.
- The site engineer / supervisor will give necessary instruction to tradesman and provide necessary construction / shop drawings.

- The site engineer / supervisor will also check that tools and equipments available are in compliance to contract requirements.
- The site supervisor also explains tradesman regarding safety pre-cautions to be observed.

METHOD OF INSTALLATION

1. Prior to commencement of work coordination will be done with other services.
2. Determine the position of Fan Coil Unit on the ceiling and mark the location of supports as per approved shop drawing.
3. Prepare and fix the Fan Coil Unit supports as per approved construction drawing and specification.
4. Ensure that Vibration Isolators of approved make, type and model are installed.
5. Install the Fan Coil Units by lifting it slowly by using suitable lifting aids (if necessary). Manufacturer's recommendations shall be followed during installation.
6. Any cut edges of angles, channels or threaded rods will be touch up with Zinc rich paint.
7. Fan Coil Units will be connected with Piping Connections complete with valves and accessories as indicated in approved shop drawing.
8. Ensure that Dielectric unions are used for piping connection to FCU's.
9. FCU Valve packages shall be provided with drain pan as shown in approved shop drawing
10. Ensure that drain connections are made with adequate slope with running trap.
11. Complete the duct connections to Fan Coil Units as shown in approved shop drawing.
12. Complete the Electrical power connection includes earthing a all respects as per approved electrical drawing and Manufacturer's recommendations.
13. Ensure that adequate space for maintenance of fan coil units and valve package is available.
14. Install the thermostat control units as per shop drawing/ Architectural PE/SS/FM drawing.
15. Complete the BMS interfacing with DDC controllers as per approved BMS drawings.

QUALITY CONTROL

- QCE along with Project Engineer and site Supervisor will monitor that all components are installed as per the contract specifications and approved submittals.
- Inspection Request (IR) shall be submitted to the Main Contractor/Consultant.

SAFETY

- Work will commence as per safety regulations laid down in the contract specification and project safety plan.
- Proper safety harness to be used and secured, if required.
- All personal protective equipment shall be used as appropriate according to the nature of job.
- Housekeeping shall be of good standard and all cut lengths and debris shall be removed.

Method Statement
Installation of Fans

APPROVED
DATE: _____

FILE NUMBER

METHOD STATEMENT FOR INSTALLATION OF FANS

SCOPE AND PURPOSE

This "Method Statement" covers the on site installation of FANS and the requirements of checks to be carried out.

REFERENCE DOCUMENTS

- Project Specifications
- Approved shop drawings (latest revision)
- Approved material submittals

GENERAL

Fans generally are installed in locations shown in drawings. Types of fans used in mainly classified as Toilet extract fans(TEF),Kitchen extract fans(KEF),Refuse fans, Lobby pressure relief fans(LRF),Stairwell pressurization fans(SPF),Car park exhaust fans, Jet fans etc.

EQUIPMENT

- Drilling Machine
- Spirit Level
- Lifting Equipments (Cranes)
- Scaffolding
- Hand tools of Trades men



RESPONSIBLE PERSONNEL

- Project Engineers
- Construction In-Charge.
- Site Engineer/Site supervisor.
- QA/QC Inspectors.
- Safety officer
- Site Foremen.
- Pipe fitters
- Helpers

METHOD OF PRE INSTALLATION

- Ensure that approved material required to carryout work will be available.
- Check the name plate details of Fans as per approved shop, drawing/schedules and material submittals before installation.
- Prior to commencement of work, area and access will be inspected to confirm that the site is ready to commence the work
- All relevant documentation and material applicable to particular section of works will be checked by site engineer before commencement.

- Physical verification of material will be carried out for any damages prior to taking from stores.
- The site engineer / supervisor will give necessary instruction to tradesman and provide necessary construction / shop drawings.
- The site engineer / supervisor will also check that tools and equipments available are in compliance to contract requirements.
- The site supervisor also explains tradesman regarding safety pre-cautions to be observed.

METHOD OF INSTALLATION

1. Prior to commencement of work coordination will be done with other services.
2. Make sure that fans are free from damage and all internal components are complete and in good condition.
3. Fan assemblies will be transported to the nearest point of erection. Care will be taken while handling the units to avoid damage/distortion.
4. Manufacturer's recommendation will be followed for installation of fans.
5. Fans will be installed in location as per approved shop drawing.

INSTALLATION OF FLOOR MOUNTED FANS

1. Ensure that builders work foundation is provided as per approved shop drawing.
2. Ensure the level of Foundation by spirit level.
3. Check the size and orientation of foundation for its suitability to install the fans.
4. Fix the Vibration Isolators to foundation as per approved submittal.
5. Install the Fan assembly mounting brackets on vibration Isolators as per manufacturer's recommendations.
6. Complete the ductwork / damper installation as per approved shop drawing.

INSTALLATION OF IN "LINE MOUNTED FANS(CEILING SUSPENDED)

1. Fans can be mounted either horizontally or vertically as per approved shop drawing.
2. Support the fans by using threaded rods to the fan casing as per manufacturer's recommendations.
3. Provide vibration isolators (approved type) as per manufacturer's recommendations on the mounting brackets/holes.
4. Complete the ductwork/damper connection as per approved shop drawing.
5. Ensure that sufficient space is available to allow removal of access covers and subsequent removal of fan and motor assemblies etc. as per manufacturer's recommendations.
6. Complete all electrical connections as per approved electrical drawing and manufacturer's terminal diagram.
7. Earthing shall be provided as per requirements.
8. Complete the labeling of electrical connections as per schematic drawings.
9. Fan rotation shall be checked before duct connection.

QUALITY CONTROL

- QCE along with Project Engineer and site Supervisor will monitor that all components are installed as per the contract specifications and approved submittals.
- Inspection Request (IR) shall be submitted to the Main Contractor/Consultant.

SAFETY

- Work will commence as per safety regulations laid down in the contract specification and project safety plan.
- Proper safety harness to be used and secured, if required.
- All personal protective equipment shall be used as appropriate according to the nature of job.
- Housekeeping shall be of good standard and all cut lengths and debris shall be removed.
- All lifting operations shall be monitored by Safety Officer.



Code No. : MS-AC-06

Method Statement
Installation of Chilled Water Pumps

10/10/2010

METHOD STATEMENT FOR INSTALLATION OF CHILLED WATER PUMPS

SCOPE AND PURPOSE

This "Method Statement" covers the on site installation of CHILLED WATER PUMPS and the requirements of checks to be carried out.

REFERENCE DOCUMENTS

- Project Specifications
- Approved shop drawings (latest revision)
- Approved material submittals

GENERAL

Chilled water Pumps generally to be installed in locations shown in drawings in the Plant Rooms.

EQUIPMENT

- Drilling Machine
- Spirit Level
- Lifting Equipments (Cranes)
- Scaffolding
- Hand tools of Trades men
- Alignment tools



RESPONSIBLE PERSONNEL

- Project Engineers
- Construction In-Charge.
- Site Engineer/Site supervisor.
- QA/QC Inspectors.
- Safety officer
- Site Foremen.
- Pipe fitters
- Helpers

METHOD OF PRE INSTALLATION

- Ensure that approved material required to carryout work will be available.
- Check the name plate details of Chilled Water Pump as per approved shop, drawing/schedules and material submittals before installation.
- Prior to commencement of work, area and access will be inspected to confirm that the site is ready to commence the work

- All relevant documentation and material applicable to particular section of works will be checked by site engineer before commencement.
- Physical verification of material will be carried out for any damages prior to taking from stores.
- The site engineer / supervisor will give necessary instruction to tradesman and provide necessary construction / shop drawings.
- The site engineer / supervisor will also check that tools and equipments available are in compliance to contract requirements.
- The site supervisor also explains tradesman regarding safety pre-cautions to be observed.

METHOD OF INSTALLATION

1. Prior to commencement of work coordination will be done with other services.
2. Make sure that the Pumps are free from damage and all internal components are complete and in good condition.
3. Chilled Water Pumps assemblies will be transported to the nearest point of erection. Care will be taken while handling the units to avoid Damage/distortion.
4. Ensure that foundations of Chilled Water Pumps are as per approved shop drawing.
5. Install Inertia base assembly on the foundation as per approved shop drawing. Ensure the orientation, axis and level of inertia base is as per approved shop drawing.
6. Fix the vibration isolators to inertia base as per approved shop drawing. Ensure that the locations are matching with Chilled Water Pump base anchoring details.
7. Complete the concrete filling in the Inertia base as per approved shop drawing.
8. Concreting of Inertia bases will be carried out by Main Contractor.
9. Install the chilled water pumps on the inertia base with vibration isolators connected to chilled water pump base frame.
10. Ensure the orientation axis and level of pump as per approved shop drawing.
11. Ensure that pump and motors are properly aligned.
12. Complete the piping connections, including Valves and accessories/flexible connections to pump suction and discharge sides as per approved shop drawing.
13. Piping connections shall be erected to allow access for operation and maintenance of pump motor and valves.
14. Make sure that the piping connections are supported properly and no imposed load of piping is transferred to the pump.
15. Complete all instrument mountings required as approved shop drawing.
16. Complete all electrical connections to pump motor with all necessary electrical protection and controls as per approved electrical shop drawing.
17. Complete the final alignment of pump and motor under manufacturer's representative's supervision.

QUALITY CONTROL

- In general, it shall be ensured by Site Engineer that product manufacturer's recommendations are

followed and shall be monitored by QA/QC Engineer. However, the following points shall be ensured, in particular;

- The appropriate and approved material is used.
- The appropriate pump is used.
- Skilled labour is employed for installation of pumps.

TESTING

- The piping connections to pumps shall be pressure tested to 1.5 times the working pressures.
- Strainer shall be cleaned after initial flushing of Chilled water piping system.
- Insulation of piping to be done after pressure testing.
- Electrical circuits / controls and connections are to be checked.

INSPECTION

- Inspection request (IR) shall be raised for consultant's inspection.
- QC inspection shall be carried out as per the installation checklist and manufacture's instructions.
- Inspection shall be recorded in the approved format.

SAFETY

- Work will commence as per safety regulations laid down in the contract specification and project safety plan.
- Proper safety harness to be used and secured, if required.
- All personal protective equipment shall be used as appropriate according to the nature of job.
- Housekeeping shall be of good standard and all cut lengths and debris shall be removed.
- All lifting operations shall be monitored by Safety Officer.

Method Statement
Installation of Air Handling Unit (AHU's)

REVISIONS

DATE

REVISIONS

METHOD STATEMENT FOR INSTALLATION OF AIR HANDLING UNITS (AHU's)

SCOPE AND PURPOSE

This "Method Statement" covers the on site installation of AIR HANDLING UNITS (AHU's) and the requirements of checks to be carried out.

REFERENCE DOCUMENTS

- Project Specifications
- Approved shop drawings (latest revision)
- Approved material submittals

GENERAL

Air Handling Units generally be installed in locations shown in drawings, serving corridors and supplying treated fresh air to the lobbies and apartments located at various floors.

EQUIPMENT

- Drilling Machine
- Spirit Level
- Lifting Equipments (Cranes)
- Rollers
- Scaffolding
- Hand tools of Trades men

RESPONSIBLE PERSONNEL

- Project Engineers
- Construction In-Charge.
- Site Engineer/Site supervisor.
- QA/QC Inspectors.
- Safety officer
- Site Foremen.
- Pipe fitters
- Helpers

METHOD OF PRE INSTALLATION

- Ensure that approved material required to carryout work will be available.
- Check the name plate details of Air handling Units as per approved shop, drawing/schedules and material submittals before installation.
- Prior to commencement of work, area and access will be inspected to confirm that the site is ready to commence the work

- All relevant documentation and material applicable to particular section of works will be checked by site engineer before commencement.
- Physical verification of material will be carried out for any damages prior to taking from stores.
- The site engineer / supervisor will give necessary instruction to tradesman and provide necessary construction / shop drawings.
- The site engineer / supervisor will also check that tools and equipments available are in compliance to contract requirements.
- The site supervisor also explains tradesman regarding safety pre-cautions to be observed.
- Ensure that all lifting operations are carried out as per approved procedure.

METHOD OF INSTALLATION

6. Prior to commencement of work coordination will be done with other services.
7. Check the foundation of AHU for size, orientation and finishes as approved shop drawing
8. Make sure that AHU's are free from damage and all internal components are complete and in good condition.
9. AHU's will be installed in location as per approved shop drawing.
10. Install the AHU's on concrete foundation by using suitable equipment recommended by manufacturer (eg. Rollers/jacks etc.). Manufacturer's recommendations will be followed during erection of AHU.
11. Multi-section units will be joined as per Manufacturer's instructions. Ensure to remove Shipping Bolts.
12. Ensure the orientation of AHU's as per approved shop drawing during installation.
13. Serrated rubber pads (Neoprene Isolator) will be provided below AHUs.
14. AHU's which are ceiling suspended will be mounted by using threaded rods, spring hangers etc. as per approval.
15. Any cut edges of angles, channels or threaded rods will be touch up with Zinc rich paint for ceiling suspended AHU's.
16. Connect all piping and accessories to AHU's as per approved shop drawing.
17. Ensure that Dielectric unions/Flanges are used for piping connection to AHU's.
18. Ensure that drain connections are made with adequate slope and approved U-trap.
19. Complete the duct connections to Air handling Units as shown in approved shop drawing.
20. Filters of specified sizes will be provided.
21. Check that adequate space for maintenance of Air Handling Units is provided as per approved shop drawing.
22. Complete the Electrical power connection including earthing in all respects as per approved electrical drawing and Manufacturer's recommendations.
23. Complete the BMS interfacing with DDC controllers as per approved BMS 9-drawings.

QUALITY CONTROL

- QCE along with Project Engineer and site Supervisor will monitor that all components are installed as per the contract specifications and approved submittals.
- Inspection Request (IR) shall be submitted to the Main Contractor/Consultant.

SAFETY

- Work will commence as per safety regulations laid down in the contract specification and project safety plan.
- Proper safety harness to be used and secured, if required.
- All personal protective equipment shall be used as appropriate according to the nature of job.
- Housekeeping shall be of good standard and all cut lengths and debris shall be removed.
- All lifting operations shall be monitored by Safety Officer.



Method Statement
HVAC Testing, Adjusting & Balancing

2011 0802 074

METHOD STATEMENT FOR TESTING, ADJUSTING & BALANCING OF HVAC SYSTEM

SCOPE AND PURPOSE

This "Method Statement" covers the on site Testing, Adjusting and Balancing of HVAC systems installed. This Method statement to be read in conjunction with project commissioning plan.

REFERENCE DOCUMENTS

- Project Specifications
- Approved shop drawings (latest revision)
- Approved material submittals

GENERAL

The HVAC system testing, adjusting, and balancing is the process of checking and adjusting all environmental systems in a building to produce the design objectives. This process includes:-

- Balancing air and water distribution systems
- Adjusting the total system to provide design quantities.
- Electrical measurements.
- Establishing quantitative performance of all equipment.
- Sound measurements.

The above procedures are accomplished by

- Checking the installations for conformity to design.
- Measuring and establishing the fluid ' quantities of the system as required to meet design specifications.
- Recording and reporting the results

EQUIPMENT

- Balometer
- Anemometer
- Micromanometer
- Pitot Tubes
- Tachometer
- Sound Meter Tester
- Water gauges (dual/single)
- Multimeter/ Tong Tester
- Hand tools of Trades men

RESPONSIBLE PERSONNEL

- Commissioning Manager
- Seder (Specialist commissioning agency) personnel

- Equipment/ system supplier (as applicable)
- Project Engineers
- Construction In-Charge.
- Site Engineer/Site supervisor.
- QA/QC Inspectors.
- Safety officer
- Site Foremen.
- Electrician
- Helpers

METHOD OF PRE INSTALLATION

- Ensure that approved material required to carryout work will be available.
- Ensure that As-Built marked up drawings are available reflecting the actual site installations.
- Prior to commencement of work, area and access will be inspected to confirm that the site is ready to commence the work
- Commissioning Manager along with representatives of Sender will carryout Visual inspection of all installations in order ensure that installations are in accordance with approved documents? In case of any discrepancy observed the same shall be brought to the notice of the Project engineer and Consultant for resolution of same.
- Ensure that all instruments are calibrated and are in proper working condition.
Prior to start commissioning that it will be ensured that all chilled water pipe work is hydrostatically pressure tested satisfactorily and all documentation is available.
- Prior to Commissioning of chilled water system, it will be ensured that all piping is satisfactorily flushed chemically cleaned. And all the pipe work is reinstated to original positions.
- Accessibility of all valves, VCD's will be ensured before start of commissioning. Where required temporary access shall be provided for VCD's.

METHOD OF INSTALLATION

1. Testing, adjusting and balancing of HVAC systems installed will be CM/SP/PE carried out as per the specialist commissioning procedures attached by specialist commissioning agency.
2. Commissioning Manager ensures that all manpower deployed by Specialist agency is competitive and sufficient to complete the TAB work.
3. All the test documentation will be recorded on the test sheets attached to the Specialist commissioning procedures.
4. Manufacturer's Representative will be associated for start equipment and as required.
5. Status of Testing and commissioning will be maintained and reported periodically to Project Managers. Consultant.

QUALITY CONTROL

- QCE in coordination with Commissioning Manager and Project CM//PE/QCE Engineer notify to Consultants for testing and commissioning of HVAC systems area wise for witnessing the same.

- QCE in association with Commissioning Manager and Project Engineer will ensure that all the test documentation is complete and signed off.

SAFETY

- Work will commence as per safety regulations laid down in the contract specification and project safety plan.
- All personal protective equipment shall be used as appropriate according to the nature of job.
- Housekeeping shall be of good standard and all cut lengths and debris shall be removed.

ATTACHMENTS:-

SEDER HVAC TAB METHOD STATEMENT ALONG WITH REPORT FORMS.



Method Statement

Flushing & Chemical Treatment Chilled Water
System

METHOD STATEMENT FOR FLUSHING & CHEMICAL TREATMENT CHILLED WATER SYSTEM

SCOPE AND PURPOSE

This "Method Statement" covers the on site flushing and chemical cleaning of the Chilled Water System installed in JBR-Sector4 including towers and podium should be read in conjunction with approved material submittal

REFERENCE DOCUMENTS

- Project Specifications
- Approved shop drawings (latest revision)
- Approved material submittals

GENERAL

Chilled water system includes pipes, fittings and valves used for transportation of chilled water to FCU's, AHU's through chilled water pumps. Flushing of system ensures removal of all contamination that may occur during manufacturing, storage and installation of piping. Chemical cleaning ensures the removal of oxides, oils and greases by using chemicals such as acids, alkalis, complexing agents etc;. Continuous monitoring of the condition of the cleaning solution by the cleaning specialist will be necessary throughout the chemical cleaning process.

EQUIPMENT

- Chilled Water Pumps
- Temporary hoses for filling/ drainage
- Temporary water tanks for disposal of chemical/ flushing water

RESPONSIBLE PERSONNEL

- AHEE MEP Coordinator
- Sr. Project Engineer HVAC
- Construction In-Charge.
- Site Engineer/Site supervisor.
- Personnel from specialist supplier
- QA/QC Inspectors.
- Safety officer
- Site Foremen.
- Electrician
- Helpers

PROCEDURE:

PRE REQUISITES FOR FLUSHING:

1. Chemical cleaning of the system will not be undertaken until the system installation has been completed, pressure tested and approved by consultant, vented and filled with clean water, static and dynamic flushing completed and circulating (system) pumps are available for operation.
2. Full access to all parts of system to be available, including access panels in ceilings, to enable access to valves, drains and vents etc.
3. Flushing will be carried out for each tower & each chilled water circuit (secondary and tertiary) separately. A detailed procedure is indicated here, which is common for all the circuits. Marked up schematic drawings for each secondary and tertiary chilled water circuit for each tower, for flushing are enclosed for reference. Following points are identified and marked in the enclosed schematic drawings for each circuit:

Note: At present only one marked up schematic drawing for CO 2 TO 2 tower, secondary circuit is attached for review & comments.

- a) Number of floors covered in the circuit.
 - b) Number of Terminal units (Heat exchangers, AHUs, FCUs) at various levels.
 - c) Fresh water filling point.
 - d) Drain point from where the system water will be drained out.
 - e) Number of terminal units at various levels, where temporary bypass loops shall be provided.
4. Before flushing work commences ensure that:
 - a) All pipe ends are looped/ closed prior to filling the water.
 - b) All valves except drain valves (gate/butterfly/globe/DRV/commissioning set valves) are fully open. Drain valves will be closed. All 2 way control valves are fully isolated. Inlet and outlet valves for terminal units, where bypass loops are not provided will be closed to avoid flushing water passing through the coils. Water will be drained from these units at the final stage of flushing before adding final chemical.
 - c) All necessary temporary bypasses installed around terminal units (heat exchangers, AHU's and FCU's) to be verified as fully open.

- d) Sufficient fresh and clean water supply is available continuously with adequate pressure at water filling point.
 - e) Drain points are properly connected / kept ready for connection to nearest drain point. Drain points will be decided in consultation with plumbing / drainage department and will be approved by Consultants.
 - f) Portable storage tanks to store drained water will be arranged, as required.
5. The objective of the flushing and cleaning treatment process is to provide acceptable water quality (defined in 6.0) and internal pipe conditions that will permit the commissioning of the systems and provide a foundation from which an effective ongoing regime of water treatment and system management can commence.
6. At all stages of the flushing and cleaning process the system will be offered for witnessing by the Consultant. The witnessing will include water quality, water quality, water analysis, pressure readings and strainer, deposits. The witnessing will be a continuous exercise and the full involvement of all witnessing parties will be required. During every stage of flushing process, for each circuit, samples of water will be taken from top & bottom level of each stage and tested an after satisfactory report next sage of flushing will commence.

FLUSHING PROCESS:

Generally flushing will be carried out in following steps for each secondary an I d tertiary chilled water circuit.

A. STATIC FLUSHING:

1. Complete system to be filled with clean water from bottom most point of the system AND vented through air vents at various locations and at the high points of the system
2. System pumps to be operated for a period of 1.2 hours to agitate any debris within the system
3. With pumps switched 'off, drain system at lowest point(s) of system all drains and air vents to be opened at same time to expedite the flushing. It is to be ensured that drain point ~is,,b&40d maximum to dram any: large sized debris in side the system. Ensure that all system is &aiii6d & no, water is remained inside the pipes
4. Check quality of drained water. Water be drained shall be collected in a separate tank (as required) and then disposed off safely or will be drained in nearest manhole available.
5. Upon completion of draining, system to be re-filled and vented with cleans water

B. DYNAMIC FLUSHING

6. Once the entire system is full of water, then valves at the branch connection to the riser at each level/floor will be closed & only valves of top five levels/floors in the circuit and the plant room floor will be opened for water circulation

The flushing velocities will be achieved by utilizing the installed circuit pumps. The number of pumps running will depend on the amount of the circuit being flushed. Prior to starting the pumps, direction, alignment and installation will be checked.

The removal of general contaminant from the system will be achieved by using a dynamic balanced flushing procedure.

System pumps will run and draw water to drain, but only at the rate at which clean water is introduced. At all times the system pressure will be maintained at such a level so as to exceed the static head. The system will not be drained during the dynamic flushing, to prevent the induction of air, which could accelerate the rate of corrosion, and also lead to air locks.

During this process, water will be drained from the lowest point at the rate fresh water is introduced in to the system. Also during this process, all the strainers in each level/floor will be opened & cleaned. Also water will be drained from the end points to ensure that dirt is not settled in the system. After every 8 to 10 hours, valves at the branch connection from the riser of the top five levels/floors will be closed & valves of next five (lower side) levels/floors will be opened for flushing. Same procedure will be followed till all the levels/floors for the entire circuit are completed. After that finally, valves at the branch connection from the riser for all the levels/floors, for the entire circuit will be kept open for water circulation for 3 to 5 hours. During this process, all the strainers in each level/floor will be once again opened & cleaned as required. At all the time during the entire process, water samples from top level & bottom level of each stage in the system will be checked for water quality.

7. The aim of the flushing process will be to initially remove all large debris from the pipe work. The pumps will be continually rotated during this process so the strainers can be cleaned. The flow in the pipes will be measured (through commissioning sets) and accordingly velocities will be recorded. These will be monitored and the strainers shall be cleaned if flow decreases. The main isolating valves may be set to create a balanced flush.
8. All strainer screens within the system will be checked and cleaned at regular intervals during the flushing process, until the screens no longer show any signs of contaminant.
9. Drain point will be kept as near to the filling point as possible to ensure that water is circulated completely in the system. Water will be drained (and make up water is introduced at the same rate), until it is as clean as the make up water. Dynamic Flushing will continue until water quality is at acceptable levels (defined in 6.0),

CHEMICAL CLEANING:

1. Cleaning chemical M-235 will be introduced into the system. Refer to the attached table. M235 to be remained in system for 24 hours and not to exceed 72 hours.
2. The chemical will be circulated throughout the system to establish an even concentration. Water samples will be taken at the lowest point, highest point and intermediate floors (if necessary) and far points of the system (locations will be identified in chilled water riser diagram and to be approved prior to proceed with flushing) and tested at regular intervals.
3. The dynamic flushing process will then be carried out again for the entire circuit, until it is free of contaminants. The parameter for acceptance of the system will be:
 - TDS (total dissolved solids) - within 10% of incoming mains water.
 - Iron - below 1 ppm.
 - Visual - clear, bright and free from particulate matter.
4. Upon successful completion of the cleaning and flushing process, system to be re- filled with clean water and vented completely. Long term corrosion inhibitors (M-381) and a chemical biocide (M-403) will be introduced into the system, in proportion to the system volume. Refer to the attached table for each building.
5. The corrosion inhibitor and biocide will be circulated throughout the system and tests undertaken to establish full circulation and correct concentration.
6. All temporary bypass loops will be removed and all Heat exchangers, AHUs & FCU coils will be back flushed. Heat exchangers, FCU / AHU coil connections will be completed for normal working conditions.

ACCEPTANCE CRITERIA

The acceptance criteria for the results of the witnessed measurements carried out in Clause 5.2.4 & 5.3.3. are that:

Static Flushing

- (1) The TDS levels achieved at the end of each high velocity flush are not greater than 10% above the incoming mains water.

Dynamic Flushing

a) Before Cleaning Chemical Addition -

Water appearance : Clear, Yellowish.

Iron Level : Less than 10ppm.
TDS : within 10% of incoming mains water.

b) After Cleaning Chemical Addition - Water

appearance : Clear.

Iron Level : Less than 1 ppm.

TDS : within 10% of incoming mains water.

(2) The velocities during each high velocity flushing stage are in excess of 1.36 m/s in the largest pipe in the system

DISPOSAL OF EFFLUENT:

The chemically treated water shall be discharged in to mobile tankers and discharged properly as per local authority regulations.

QUALITY CONTROL

- Project Engineer along with Specialist supplier will monitor the flushing process and ensures that same is in full compliance as per approved submittals.
- Quality Control Engineer will coordinate with Consultant for all witnessing activities during chemical cleaning process

SAFETY

- Where chemical cleaning is being carried adequate notices will be displayed for " NO SMOKING" and Warning Signs.
- All tradesmen engaged will be given proper safety orientation for chemicals being used. And appropriate personnel protective equipments will be provided.
- Continuous monitoring will be carried out by trained operatives for any emergency actions.
- Ensure that good house keeping at all times.

Section 11

Method Statement for Plumbing Installation

NOTES: 1. 2. 3. 4. 5. 6. 7. 8. 9. 10. 11. 12. 13. 14. 15. 16. 17. 18. 19. 20. 21. 22. 23. 24. 25. 26. 27. 28. 29. 30. 31. 32. 33. 34. 35. 36. 37. 38. 39. 40. 41. 42. 43. 44. 45. 46. 47. 48. 49. 50. 51. 52. 53. 54. 55. 56. 57. 58. 59. 60. 61. 62. 63. 64. 65. 66. 67. 68. 69. 70. 71. 72. 73. 74. 75. 76. 77. 78. 79. 80. 81. 82. 83. 84. 85. 86. 87. 88. 89. 90. 91. 92. 93. 94. 95. 96. 97. 98. 99. 100.

Method Statement
Concealed Drainage Piping

MECHANICAL

METHOD STATEMENT FOR CONCEALED DRAINAGE PIPING

SCOPE AND PURPOSE

This "Method Statement" provides the detailed account of the installation and testing of concealed drainage pipes in toilets from Level 1 and up in all towers.

REFERENCE DOCUMENTS

- Project Specifications
- Approved shop drawings (latest revision)
- Approved material submittals

GENERAL

Installation of drainage pipes within the concrete slab in toilets, garbage rooms, balconies etc from level 1 and up in towers, shall be done in accordance with the project specifications and drawings.

EQUIPMENT

- Spirit Level, Water Level
- Measuring tape, Nylon twine
- Pipe cutter, Hack saw, Files, Trimmers etc
- Marking tools, Plumbers tool box, Hammers

RESPONSIBLE PERSONNEL

- Project Engineers
- Site Engineer/Site supervisor
- QA/QC Inspectors
- Safety officer
- Site Foremen
- Plumbers
- Helpers

METHOD OF PRE INSTALLATION

1. Approved materials shall be purchased in accordance with the approved shop PE / SS drawings and For Construction Contract Specifications.

2. Proper materials including pipes and fittings are to be selected and used PE / SS according to approved shop drawing and good engineering practices.
3. Adequate stock of material, tools and tackles, testing equipments and PE / SS consumables along with sufficient man power shall be arranged to carry out the work.
4. Site supervisors are to be provided with the civil work schedules for the following works:
 - a. Shuttering works
 - b. Bottom Reinforcement fixing works
 - c. Top Reinforcement fixing works and
 - d. Concreting works
5. Site supervisors are to be provided with the finished floor level as well as structural floor level by the civil surveyors at site before starting marking of pipe line route on shuttering.
6. Ensure that the location of masonry walls, concrete walls, shafts, grid lines etc are marked by the main civil contractor on slab shuttering.
7. Thickness of plastering, tiling etc with tile modules and thickness of screed and flooring are to be finalized and produced at site before execution of piping work.
8. Ensure that the construction power and water for testing of pipes are provided by the main contractor near to the work place
9. Safe and tidy work place, clear access to the work place, modes to shift material, tools and tackles etc are to be ensured.
10. Civil works including reinforcement schedules should be designed to accommodate the drainage pipes with proper slope and level.

PIPING :

1. Main Contractor's Surveyor to mark the locations of Floor gullies, sanitary fittings etc as per approved shop drawing and revised architectural drawing on shuttering before putting the reinforcement. Information regarding completion of marking to be given to VL Supervisors etc.
2. Main Contractor to fix bottom reinforcement and inform VL supervisors. VL to install all pipes and fittings as per approved shop drawing and as follows.
 1. Ensure that the pipes are cut square before they are placed inside the reinforcement.
 2. Use cleaning fluid on both surfaces to be joined. This removes all dirt and machine

release agents for the chemical solvent weld. Failure to do this can result in joint failure.

3. Apply solvent cement evenly over mating surfaces of both pipe and socket.
4. Insert pipe into socket with slight twisting action to full socket depth.
5. Surplus cement should be removed with a cloth.
6. The joint should be firm enough to handle in 5 minutes.
7. Pipe runs are to be placed and tied to reinforcement considering proper slope and gradient as per approved shop drawings.

3. Pipes and fittings which are push fit types are to be connected as follows

1. Lubricate the pipes cut in square and chamfered as well as fittings with rubber lubricant and push fit to full socket depth.
 2. Withdraw pipe 5 mm on waste system and 10 mm on soil system to allow for expansion.
 3. Soil fittings with spigot ends should be inserted into sockets to depth marks engraved on spigot.
 4. This procedure automatically allows for expansion.
 5. Pipe runs are to be placed and tied to reinforcement considering proper slope and gradient as per approved shop drawings.
4. Main Contractor to install Top reinforcement in the slab taking adequate care to ensure that drainage pipes / fittings are not damaged / disturbed etc. VL to ensure that pipes are tied securely to bottom, top reinforcement and stirrups so that they are not displaced at the time of concreting.
5. All Fire Stopping related works to MEP services viz. pipes entering / exiting Fire rated Walls etc to be done by Main Contractor.

W/ CHANDRAN

TESTING :

1. Hydraulic testing of the pipes jointed with solvent cement should be done after 1 hours of jointing.
2. Check for gradient and slope before filling water.
3. Extend one of the pipe ends to attain the required head of 1.5 m for hydraulic testing.
4. Compression type rubber plugs are to be used to plug all open pipe ends.
5. Fill the entire pipe network with fresh clean water up to the required height of 1.5 m from the highest point.
6. Keep the water with the head required for 6 hours for testing.
7. Check the joints for any leakage also the fall in water level in the Vertical Pipes. Any leakage found is to be rectified immediately and tested again.

8. Concreting to be done only after hydraulic testing of pipes has been successful and witnessed by the engineer.
9. Concreting to be poured over the pipe using mortar pans and compacting to such that needles do not touch the hydraulically tested pipes. Main Contractor to ensure that the pipes / fittings etc are not disturbed during concreting operations. This is critical to ensure alignment of pipe work is maintained as well as preventing damage.
10. Water filled into pipes to be retained and monitored for the entire duration of concreting so that at any displacement of joints and, subsequent leakages can be monitored.
11. If the above mentioned situations arise, concreting over that particular area is to be stopped, 'and rectification of displaced, pipes,' sealing of joints etc to be taken up immediately. Main contractor to wait until the rectification is carried out properly to VL Supervisor/Foreman's satisfaction.
12. Follow items 1-8 above after rectification.

POST INSTALLATION PROCEDURE

1. Ensure to prepare As-Built Drawings as soon as possible after the work is completed.
2. Location of the concealed drainage piping will be marked on the suffix as per As-built or redline (As-built marked up) drawings to avoid any drilling or related activity to prevent damage to the concealed drainage piping.

QUALITY CONTROL

- OCE along with Project Engineer and site Supervisor will monitor that all components are installed as per the contract specifications and approved submittals.
- Inspection Request (IR) shall be submitted to the Main Contractor/Consultant during the following stages of work have been completed :-
 - Inspection of Piping installation and hydraulic testing

SAFETY

- Work will commence as per safety regulations laid down in the contract specification and project safety plan.
- Proper safety harness to be used and secured, if required.
- All personal protective equipment shall be used as appropriate according to the nature of job.
- Housekeeping shall be of good standard and all cut lengths and debris shall be removed.

Method Statement

Installation of Above Ground Drainage Piping

REVISIONS

METHOD STATEMENT FOR INSTALLATION OF ABOVE GROUND

DRAINAGE PIPING

SCOPE AND PURPOSE

This "Method Statement" covers the on site installation of above ground drainage piping and the requirements of checks to be carried out.

REFERENCE DOCUMENTS

- Project Specifications
- Approved shop drawings (latest revision)
- Approved material submittals

GENERAL

Above Ground drainage piping is generally be installed in podium, risers and lobby areas as per locations shown in approved shop drawings.

EQUIPMENT

- Drilling Machine
- Spirit Level
- Measuring Tape
- Nylon twine
- Pipe Cutter, Hack Saw, Files Trimmers etc
- Hammers
- Ladders
- Scaffolding
- Hand tools of Tradesmen

RESPONSIBLE PERSONNEL

- Project Engineer (Plumbing)
- MEP Coordinator(Main Contractor)
- Construction In-Charge
- Site Engineer/Site supervisor
- QA/QC Engineer
- Safety Officer
- Site Foremen
- Helpers

METHOD OF PRE INSTALLATION

- Ensure that Above Ground Drainage Piping Material received are inspected and found acceptable as per approved material submittal, are available to carry out the work.
- Proper Material including pipes and fittings are to be selected and used in accordance with approved shop drawings.
- Ensure that all related material (Supports/Solvent Cement/Lubricants) of approved make is available before carrying out any work.
- Prior to Commencement of work, areas and access will be inspected to confirm that site is ready to commence the work and all relevant shop drawings dully approved for construction.
- All relevant documentation (Drawings) and Material applicable to particular section of works will be checked by Site Supervisor prior to commencement of work.
- The Site Engineer/ Site Supervisor will give necessary instructions to tradesman (Plumber) and provide necessary approved construction/ shop drawings to latest revision along with coordinated lay outs.
- Ensure that location of grid lines, reference levels are marked by Main Contractor.

• ***INSULATION OF HORIZONTAL RUNS***

- 3.1 Mark the route of above ground drainage piping on the soffit of slab.
- 3.2 Determine the position of support and fix the supports using anchor bolts and ensure that all fixings (threaded rods, angles, clamps etc.) are straight and secure.
- 3.3 Install the Drainage pipes on to the supports. Ensure proper slope and gradient is maintained for all horizontal runs of Drainage piping.
- 3.4 Install all pipes and fittings as per the following procedure .
 - Ensure that the pipes are cut square before they are joined.
 - Use cleaning fluid on both surfaces to be joined. This removes all dirt and machine release agents for chemical solvent weld. Failure to do this can result joint failure.
 - Apply solvent cement evenly on mating surfaces of both pipes and socket.
 - Insert pipe into socket with slight twisting action and full socket depth.
 - Surplus cement should be removed with a cloth.
 - The joint should be firm enough to handle in 5 minutes.

3.5 Pipes and fittings which are push fit types are to be connected as follows:

- Lubricate the pipes cut in square and chamfered as well as fittings with rubber lubricant and push fit to full socket depth.
- With draw pipe 5mm on waste system and 10mm on soil system to allow it for expansion.
- Soil fittings with spigot ends should be inserted into sockets to depth marks engraved on spigots. This procedure automatically allows for expansion.

• **INSULATION OF VERTICAL RISERS**

- 3.1 Ensure that the shafts are clear and through up to maximum 6 floors above.
- 3.2 Ensure that the required provision for maintenance of shaft piping is provided in the block work as per approved drawing.
- 3.3 The inside faces of shaft to be finished before fixing of the vertical riser pipes.
- 3.4 Make sure that proper working platforms are made for safe working inside the shaft.
- 3.5 Make sure that all pipes protruding out from the slab of the corresponding toilets are in plumb.
- 3.6 Mark the location of vertical riser and fix the supports (as per approval) at intervals as specified.
- 3.7 Fix the pipe fittings on the outlet pipes protruding from the slab and align to the plumb of the vertical riser.
- 3.8 Joining of pipes and fittings will be carried out as per clause 2.4 & 2.5 above.
- 3.9 Fix the clamps (as per approval) to vertical riser pipes at specified intervals of 1.6M which are already fixed to the structural members.
- 3.10 At every five (5) levels additional support with U- Clamp will be provided. Anchor supports to be provided for vertical loads at each directional change.
- Each directional change or water testing of riser pipes will be carried out after completing the installation of riser pipe.
 - Riser to be tested with minimum 1.5m water head at eight point / air tested. While testing risers all horizontal floor toilets / WP's etc. will be disconnected / isolated.

QUALITY CONTROL

- QCE along with Project Engineer and site Supervisor will monitor that all components are installed as per the contract specifications and approved submittals.
- Inspection Request (IR) shall be submitted to the Main Contractor/Consultant after completion of installation of riser pipes along with testing.

SAFETY

- Work will commence as per safety regulations laid down in the contract specification and project safety plan.
- Proper safety harness to be used and secured, if required.
- All personal protective equipment shall be used as appropriate according to the nature of job.
- Housekeeping shall be of good standard and all cut lengths and debris shall be removed.
- Ensure that proper scaffolding/ ladders are available.
- Ensure that shafts are adequately blocked above and below the working level, so that no fall of debris/ materials takes place.

Code No. : MS-PL-03

Method Statement
Domestic Water (Hot & Cold) Supply Piping

MS-PL-03

METHOD STATEMENT FOR DOMESTIC WATER (HOT & COLD) SUPPLY

PIPING

SCOPE AND PURPOSE

This "Method Statement" covers the on site installation, testing and insulation of the Domestic Water Supply Piping including Secondary risers and the requirements of checks to be carried out.

REFERENCE DOCUMENTS

- Project Specifications
- Approved shop drawings (latest revision)
- Approved material submittals

GENERAL

Domestic Water Supply Piping System includes Hot Water Supply Piping, Cold Water Supply Piping, Risers, fittings, valves and accessories used for supply of water to Toilets, Kitchen and Utility rooms.

EQUIPMENT

- Drilling Machine
- Cutter for PVC Pipes
- Welding machine for PP-R
- Pressure Test Pump
- Hammers
- Ladders
- Scaffolding
- Hand tools of Tradesmen

RESPONSIBLE PERSONNEL

- Project Engineer (Plumbing)
- MEP Coordinator(Main Contractor)
- Construction In-Charge
- Site Engineer/Site supervisor
- QA/QC Engineer
- Safety Officer
- Site Foremen
- Helpers

METHOD OF PRE INSTALLATION

1. Ensure that approved materials are available to carry out the work.

2. Proper materials including pipes, fittings and associated accessories are with drawn from stores according to approved shop drawing and good engineering practices.
3. Physical verification of materials will be carried out for any damages prior to taking from stores.
4. Prior to Commencement of work , areas and access will be inspected to confirm that Site is ready to commence the work.
5. All relevant documentation (Drawings) and Material applicable to particular section of works will be checked by Site Supervisor prior to commencement of work.
6. The Site Engineer/ Site supervisor will give necessary instructions to tradesmen (Pipe fitters/welders) and provide necessary approved Construction/Shop Drawings along with coordinated layouts.
7. The Site Engineer/Foremen will also check that proper tools and equipment are available to carry out the work and are in compliance with contract specification.
8. The Site Engineer also explains the tradesmen regarding safety precautions be observed.
9. Prior to Hydrostatic Pressure testing, Site Engineer will ensure that calibrated pressure gauges are available and are in good condition.

METHOD OF INSTALLATION

1. Foremen will carryout a site survey and mark the route of water supply Piping (Hot & Cold) as per approved shop drawings. In the event that there are any discrepancies or difficulties in executing the work, these will be brought to the notice of Project Engineer for corrective action.
2. Co-ordination with other trades will be carried out while marking the route of piping.
3. Determine the position of support and fix the supports using anchor bolts and ensure all fixing are tight and secure. While drilling the soffits, ensure that there is no damage to embedded services in the slab.
4. Any cut edges of angles, channels or threaded rods will be touch up with Zinc rich paint.
5. Install the pipes in position on the supports. Wherever possible pre-assembly of pipes and fittings at ground level will be carried out.
6. Assemble the pipes and fittings as per approved shop drawing.
7. Assemble of U-PVC pipes and Fittings by using Solvent cement. Ensure that joints are clean before applying solvent cement.
8. For joining of PP-R Pipes and Fittings manufacturer's recommendations will be followed (Copy enclosed).

9. For fixing PEX pipes, ensure that wall chases are done properly by Main Contractor as per locations shown in approved shop drawing.
10. Fix the female elbow with cover to be located at proper height as per approved shop drawing. Ensure the line and alignment with wall tiling.
11. Install the PEX pipes with sleeves (Conduit) in the wall chases. Ensure that joint between PEX pipe and female elbow is proper and leak free.
12. Fix the PEX pipe to Water supply lines by using male adaptors.
13. Spacing between supports / hangers will be maintained in accordance with latest approved shop drawings/ manufacturer's recommendations
14. Ensure all open ends of pipes, fittings and valves are covered with polyethylene sheet before leaving work space.

15. INSTALLATION OF VALVES AND ACCESSORIES

- 15.1 Install system valves and accessories as per latest approved shop drawings.
- 15.2 Ensure that system equipment, valves and accessories are secure and rigid.
- 15.3 The installation shall be done allowing sufficient access to all valves/ strainers/ gauges as per Manufacturer's recommendations.

16. INSTALLATION OF WATER SUPPLY RISERS

- 16.1 Pipe sizes will be identified first as per latest approved shop drawing and shifted to respective floors.
- 16.2 Install the supports as per approved Shop drawing/ Manufacturer's recommendations.
- 16.3 Joining of pipes will be carried out as per above procedure (refer clause 6.2.7 & 8).
- 16.4 After installation of risers check the pipeline for proper alignment and supports.

17. HYDROSTATIC PRESSURE TESTING

- 17.1 Complete pipe work will be subjected to hydraulic pressure tested as per technical specification. Depending on ongoing Construction activities sectional hydro testing will be under taken to meet the requirements of the programmed. Test pressure will not be less than 1.5 times the working pressures but not less than 1035 KPa (for Two hour period) which ever is greater. Prior to any testing the system pressure will be shown on the pressure testing documentation.

- 17.2 Pressure gauges used for Pressure testing will have valid calibration certificate.
- 17.3 After successful Pressure testing ensures that piping system is fully drained and released for insulation and other related activities.

18 INSULATION

- 18.1 Insulation of water pipe work will be carried out as per details as shown in approved submittals. Thermal insulation of joints will be carried out after pressure testing.
- 18.2 Make sure that Pipes are clean before applying any insulation. Follow manufacturer's recommendation for insulation of water supply piping (copy enclosed).
- 18.3 Ensure thickness of insulation is as per approved drawing.
- 18.4 Identification Bands/ Labeling will be located at is at access panel locations.

QUALITY CONTROL

- QCE along with Project Engineer and site Supervisor will monitor that all components are installed as per the contract specifications and approved submittals.
- Inspection Request (IR) shall be submitted to the Main Contractor/Consultant for the following stages:-
 - After completion of installation prior to Hydrostatic Pressure Test.
 - Pressure testing of piping
 - After completion of insulation before ceiling clousure.

SAFETY

- Work will commence as per safety regulations laid down in the contract specification and project safety plan.
- Proper safety harness to be used and secured, if required.
- All personal protective equipment shall be used as appropriate according to the nature of job.
- Housekeeping shall be of good standard and all cut lengths and debris shall be removed.

Method Statement
Installation of Water Heaters

REVISION

METHOD STATEMENT FOR INSTALLATION OF WATER HEATER

SCOPE AND PURPOSE

The scope and purpose of this method statement is to define the method of storage, handling, installation and inspection of the Water Heaters as per specification and manufacturers instructions

REFERENCE DOCUMENTS

- Project Specifications
- Approved shop drawings (latest revision)
- Approved material submittals

EQUIPMENT

- Drilling Machine
- Cutter for PVC Pipes
- Gloves
- Spirit Level
- Measuring Tape
- Ladders
- Scaffolding
- Hand tools of Tradesmen



RESPONSIBLE PERSONNEL

- Project Engineer
- Site Engineer/Site supervisor
- QA/QC Engineer
- Safety Officer
- Site Foremen
- Plumbers
- Helpers

METHOD OF PRE INSTALLATION

4.1 Receiving

- When received at site, heaters shall be checked for quantities, model numbers and physical damages, if any discrepancies are noticed, inform supplier for replacement of the same.
- P&T Valves shall be checked for size, model and quantity.
- Check for Test Certificates, Country of Origin Certificate, Spares (if any) and Operation and Maintenance Manual for the supplied heaters.
- Request for Inspection shall be raised for Consultants inspection.

- The storekeeper, engineer and QC Engineer of ETA shall conduct receiving inspection.
- Any items found damaged or not found suitable as per the project requirements shall be quarantined, non-compliant materials shall be clearly marked and stored separately to prevent any inadvertent use until returned to vendor.

4.2 Storage

- Upon completion of receiving QC inspection the heaters will be segregated model / size wise and stored accordingly for easy retrieval.
- Water heaters shall be stored on a flat surface in ventilated and covered area and protected from dust.
- Inlet, outlet and return point's blanks shall not be removed until ready for connection to pipe work.
- Manufacturer's instruction shall be strictly followed as applicable.
- Storekeeper will be responsible for proper storage and maintenance of records, as required

4.3 Preparation

- Check and ensure that the shop drawings used are latest and approved for construction.
- Check coordination with other services prior to the installation.
- Check the piping supports locations and power supplies routing locations in coordination water heater and piping layout and ensure it does not obstruct the space around water heater for removal and maintenance.
- Ensure easy access and sufficient clearance for servicing and maintenance i.e. for replacement of water heaters, thermostat, heating elements.

METHOD OF INSTALLATION

16. Ceiling Suspended Water Heaters

- Install the fabricated water heater support as per approved details.
- Install the water heater on the support.
- Remove the end caps on the inlet, outlet points. Complete the piping and valve package installation as per approved drawings. .
- Install the electrical power connections as per approved drawings.
- Check and ensure availability of adequate access for removal and maintenance of water heater.
- Provide grounding wiring as per approved drawings / suppliers instruction.
- Ensure compliance to the manufacturers instructions while installing the water heaters.
- After completion of the installation, Inspection Request shall be raised for Consultants approval.

17. Floor Mounted Water Heaters

- Mark the locations of the Water Heater base frame and hole locations on the foundation.
- Drill the suitable size holes in the foundations.
- Install the water heater on the foundation.
- Remove the end caps on the inlet, outlet points. Complete the piping and valve package installation as per approved drawings.
- Install the electrical power connections as per approved drawings.
- Connect the P&T valve to the nearest floor drain.
- Check and ensure availability of adequate access for removal and maintenance of water heater.
- Provide grounding wiring as per approved drawings / suppliers instruction.
- Ensure compliance to the manufacturers instructions while installing the water heaters.
- After completion of the installation, Inspection Request shall be raised for Consultants approval.

EXCEPTION

DISPENSE

QUALITY CONTROL

- QCE along with Project Engineer and site Supervisor will monitor that all components are installed as per the contract specifications and approved submittals.
- Inspection Request (IR) shall be submitted to the Main Contractor/Consultant after completion and water heater installation and pipe connection.

SAFETY

- Work will commence as per safety regulations laid down in the contract specification and project safety plan.
- Proper safety harness to be used and secured, if required.
- All personal protective equipment shall be used as appropriate according to the nature of job.
- Housekeeping shall be of good standard and all cut lengths and debris shall be removed.

Method Statement
Installation of Domestic Water Supply Pumps

1001-011-001

METHOD STATEMENT FOR INSTALLATION OF DOMESTIC WATER

SUPPLY PUMPS

SCOPE AND PURPOSE

The scope and purpose of this method statement is to define the method of storage, handling, installation and inspection of the Domestic Water Supply Pumps and the controller as per specification and manufacturers instructions.

REFERENCE DOCUMENTS

- Project Specifications
- Approved shop drawings (latest revision)
- Approved material submittals

EQUIPMENT

- Drilling Machine
- Cutter for PVC Pipes
- Gloves
- Spirit Level
- Measuring Tape
- Fork Lift, Crane
- Scaffolding
- Hand tools of Tradesmen

RESPONSIBLE PERSONNEL

- Project Engineer
- Site Engineer/Site supervisor
- QA/QC Engineer
- Safety Officer
- Site Foremen
- Plumbers
- Helpers

METHOD OF PRE INSTALLATION

4.4 Receiving

- When received at site, each pump, valves, control panels, float switches shall be checked for quantities, Model Nos., physical damages etc. and notify supplier of any discrepancies for suitable rectification or replacement
- Check for Test Certificates, Country of Origin Certificate, Spares (if any) and Operation and Maintenance Manual for the supplied pumps.

- Request for Inspection shall be raised for Consultants inspection.
- Valves shall be segregated as per sizes/models and stored on racks within a covered store.
- Any items found damaged or not found suitable as per the project requirements shall be quarantined. Non-compliant material shall be clearly marked and stored separately to prevent any inadvertent use until returned to vendor.

4.5 Storage

- Pump shall be stored on a flat surface in well ventilated storage area.
- Inlet and outlet flange blanks shall not be removed until ready for connection to pipe work.
- Manufacturer's instructions shall be strictly followed as applicable.
- If the pumps are stored for longer periods the shaft shall be periodically rotated and lubricated, if required.
- The stored pump should be inspected periodically for obvious conditions such as' . standing water, parts theft, excess dirt buildup or any other abnormal condition.
- Storekeeper will be responsible for proper storage and maintenance of records, as required.

4.6 Preparation

- Civil Contractor (AHEE) shall provide the foundations designed to meet the vibration and sound control requirements.
- Check and ensure that the shop drawings used are latest and approved for construction.
- ETA shall co-ordinate the location of foundation as per approved shop drawings.
- The foundation surface shall be flat and level and smoothly finished top surface.
- Check the piping support locations and cable tray routing locations in co-ordination with pump and piping layout and ensure they are not obstructing the space around pump.
- Ensure easy access and sufficient clearance for servicing and maintenance i.e for replacement of pump, motor, pressure vessel.

METHOD OF INSTALLATION

- Mark the locations of the pump base frame and hole locations.
- Drill the suitable size holes in the foundations.
- The pump and the other associated accessories including the piping manifold are pre-assembled on a base frame. Shift the pumps to the place of installation in safe manner. Use hand trolley / folk-lift/ crane as applicable/ required as per site conditions.
- Check and ensure free rotation of the shaft.
- Position the pump frame assembly on the foundation and fix the anchor fasteners.

- Water level the pump assembly by placing the shim plates below the base frame as required. After the installation the pump supplier shall recheck the gap between ' motor and pumps before testing as applicable.
- Position the pressure vessel and do the interconnecting pipe work as per approved drawings.
- Ensure proper coupling guards are provided if required.
- Complete the piping and valve package installation as per approved drawings. Remove the end caps fixed on the inlet flange.
- Install the electrical control panel and power connections as per approved 'r drawings.
- Provide grounding wiring as per approved drawings / manufacturers instruction.
- Follow the manufacturer's instructions while installing the pump.
- After completion of the installation, it shall be checked and certified by the local p supplier.

QUALITY CONTROL

- QCE along with Project Engineer and site Supervisor will monitor that all components are installed as per the contract specifications and approved submittals.
- Inspection Request (IR) shall be submitted to the Main Contractor/Consultant after completion and water heater installation and pipe connection.

SAFETY

- Work will commence as per safety regulations laid down in the contract specification and project safety plan.
- Proper safety harness to be used and secured, if required.
- All personal protective equipment shall be used as appropriate according to the nature of job.
- Housekeeping shall be of good standard and all cut lengths and debris shall be removed.

Method Statement
Installation of Sanitary Fixtures

REVISIONS

METHOD STATEMENT FOR INSTALLATION OF SANITARY FIXTURES

SCOPE AND PURPOSE

This "Method Statement" covers the on site installation of sanitary fixtures, fittings and various accessories associated with sanitary ware.

REFERENCE DOCUMENTS

- Project Specifications
- Approved shop drawings (latest revision)
- Approved material submittals

EQUIPMENT

- Drilling Machine
- Spirit Level
- Nylon twine
- Hand tools of Tradesmen

RESPONSIBLE PERSONNEL

- Project Engineer
- Site Engineer/Site supervisor
- QA/QC Engineer
- Safety Officer
- Site Foremen
- Plumbers
- Helpers

METHOD OF PRE INSTALLATION

1. Ensure that all Sanitary Ware and associated accessories supplied by Main Contractor are as per approved material submittals and are inspected and found acceptable as per approved material submittals and are available to carry out the work.
2. On receiving the Sanitary Ware for installation, careful inspection of material will be done for damage to the material. Such damaged material will be returned to supplier through the Main Contractor after making a proper inspection report..
3. The Sanitary Ware will be stocked in properly ventilated stores as per the recommendations of the manufacturer. Care will be taken that no heavy material will be kept in overhead locations above the storage space for Sanitary Ware to avoid any damages. While storing the Sanitary Ware metal to ceramic contact will be avoided as.-possible. While storing sufficient spacing will be ensured for easy lifting and loading. Storage will be provided by the Main Contractor.

4. Prior to commencement of work, areas and access will be inspected to confirm that the Site is ready to commence the work.
5. All relevant documentation (drawings) and Material applicable to particular section of works will be checked by Site Supervisor prior to commencement of work.
6. The Site Engineer/ Site Supervisor will give necessary instructions to tradesmen and provide necessary approved construction/shop drawings of the latest revision along with coordinated layouts.
7. The Site Engineer/Foremen will also check that proper tools and equipment are available to carry out the work and are in compliance with the contract specification.
8. The Site Engineer will also explain to the tradesmen regarding safety precautions to be observed.

METHOD OF INSTALLATION

1. Prior to starting the installation of Sanitary fixtures, fittings and accessories it will be ensured that all pipe work in the toilets/kitchens are installed properly and tested according to approved methods, and there is no damage to the pipe work. In short all first fix and second fix of the plumbing services will be completed before sanitary wares are installed.
2. All pipe supports, valves, floor drains, floor clean out will be checked for accuracy of installation.
3. The locations and sizes of piping and drainage outlets will be checked for their compatibility with sanitary fixtures.
4. All other works, especially floor and wall tile work painting are completed prior to installation of sanitary ware.
5. Ensure that all drainage pipe work is flushed out and debris removed from the pipe work.
6. Identify the models of Sanitary Ware to be installed as per approved drawings/submittals.
7. **WATER CLOSET**
 - Ensure that no damage has occurred due to transport to site, and all fittings, fixing screws are available inside the packing.
 - Fix the water supply angle valve to the pipe connection on the wall with escutcheon plate.
 - Cut the soil drain pipe to the required length to fit the W.C. bowl outlet.
 - Install the approved sealing flange connector supplied by the manufacturer on the drainage outlet.
 - Place the closet in the locations and adjust to the dimensions as per Approved shop drawing. Follow manufacturer installation instructions.
 - Mark the holes for fixing screws on the floor, and drill with correct size drill bit to the required depth. Place the anchors in the drill holes.
 - Clean the floor under the W.C. closet and put in place fixing studs carefully observing the levels at all times.
 - Seal the base of the water closet unit with approved sealant and allow it to dry.
 - Assemble the flushing mechanism of the water cistern ensuring that all rubber seals for the screws and water connecting pipes are in place.
 - Connect the cistern with water supply angle valve using a connecting piece of pipe of appropriate

length supplied along with Sanitary ware.

- Fix the seat and cover to the W.C. bowl using fixing screws provided by the manufacturer.
- Secure the W.C. unit against misuse/damage by using proper protection.

8. BIDET

- Check the location and position of bidet based on approved shop drawings.
- Re-examine the rough in connections for hot and cold water supply and waste outlet trap connection.
- Fix the angle valves with escutcheon plate on the rough in pipe connections for the cold and hot water supply and tighten till flush to the wall.
- Cut the waste outlet pipe to the required length and fix the waste coupling provided on the pipe end as per manufacturer recommendations.
- Fix the mixer on the bidet and tighten the underside nut, connect the plug lever arm to the waste coupling.
- Place the bidet in position and mark the holes for the fixing screws ensuring that waste opening is aligned with waste piping.
- Drill the holes with correct size of drill bit to the required depth and anchor fasteners. On completion clean the floor in position of the bidet.
- Place the bidet in position and insert the fixing screws in the holes and tighten them carefully.
- Connect the Bidet mixer and the angle vales by using a connection piece of pipe supplied and tighten them with coupling nuts.
- Place the waste strainer in the drain opening of bidet.
- Apply sealant around the base of the bidet.
- Secure bidet against misuse/ damage by using proper protection.

9. BATH TUB

- Check the location and type of bath tub and mixer according to approved shop drawing.
- Examine the rough in piping connections for hot and cold water supply and waste out let. Check the distances and tolerances as per approved shop drawing, and manufacturer's recommendations.
- Mark the position of the bath tub and ensure the waste connection is centered with the waste coupling and the height from the floor is correct as per approved drawing.
- Place the bath tub on block work as recommended by manufacturer.
- Adjust the level of the tub using s spirit level and fix the waste strainer on the waste opening and tighten the screws.

- Fix the bath tub Make by placing the concrete, mortar under and around it as recommended by manufacturer. Ensure that there is no damage to the bath tub while carrying out civil works around it. Civil works by Main Contractor.
- After civil works are completed and location is clean and ready, fix the bath tub mixer and hand shower, shower rail as per approved drawing.
- Protect the bath tub against any misuse/ damage by appropriate methods.

10. SHOWER TRAY

- Examine the location and position of the shower tray according to the approved shop drawing.
- Check in rough in piping connections for hot and cold water supply to the shower mixer and waste piping connections for their locations according to approved shop drawing.
- Place the shower tray in position and align the waste opening. Adjust the level of shower tray using spirit level.
- Fix the waste strainer on the waste opening and tighten the screws.
- Place the concrete mortar under the shower tray according to manufacturer's instructions and complete the finishing works regarding tiling and wall finishes shower cubicles etc. as per approved shop drawing.
- Place the protective coverings over shower tray and mixer.

11. WASH BASIN

- Examine the location and place of wash basin as per approved shop drawing.
- Identify the model of the wash basin, check all dimensions, tolerances, and levels of the rough in water and drainage piping are matching with the wash basin to be installed as per approved shop drawing.
- Mark the holes for fixing stud on the walls, using template provided by the manufacturer.
- Drill the holes with the correct size of drill bit to the required depth and anchor fasteners in position.
- Place the threaded studs in the holes and fix the wash basins with washer and nuts.
- Check the level of the wash basin by spirit level and coordinate the levels with counter top position.
- Install bottle trap on waste out, fix the strainer on wash basin and tighten the strainer screw.
- Connect to the waste pipe on the wall and fix the escutcheon plate supplied by manufacturer to conceal piping joint.
- Fix the angle valves for cold and hot water supply flush to the wall, using escutcheon plates.
- Install water mixer on the wash basin and connect the mixer and angle valves by using tubes. Tighten the coupling nuts ensuring that installation is tidy.

- After complete installation protect the wash basins from any misuse/damage.

12. KITCHEN SINK

- Check the rough in dimensions for cold and hot water supply and waste pipe ensuring that all pipe sizing and positions are as per approved shop drawings.
- Identify the model of kitchen sink as per approved shop drawing and carefully transfer the unit to installation location to match with counter top.
- Install the angle valves for hot and cold water supply. Place the kitchen sink in place and adjust its level and location to match with counter top. Support the sink on counter top and apply silicon sealant around sink edges with the counter top.
- Connect the mixer with flexible hose to the angle valve and tighten them with coupling nuts.
- Connect the bottle trap assembly to the sink bowl and fit with the drain pipe in wall and seal the joint with rubber sealing connector of appropriate size.

QUALITY CONTROL

- QCE along with Project Engineer and site Supervisor will monitor that all components are installed as per the contract specifications and approved submittals.
- Inspection Request (IR) shall be submitted to the Main Contractor/Consultant after completion of Installation of sanitary fixtures.

SAFETY

- Work will commence as per safety regulations laid down in the contract specification and project safety plan.
- Proper safety harness to be used and secured, if required.
- All personal protective equipment shall be used as appropriate according to the nature of job.
- Housekeeping shall be of good standard and all cut lengths and debris shall be removed.

Section 12

SECTION

SECTION

SECTION

Method Statement for Fire Fighting Installation

Method Statement
Installation of Pipes & Fittings

METHOD STATEMENT FOR INSTALLATION OF PIPES & FITTINGS

SCOPE AND PURPOSE

This "Method Statement" covers the Installation of Pipes and Fittings. This will also ensure workmanship and conforms to Contract documents.

REFERENCE DOCUMENTS

- Project Specifications
- Approved shop drawings (latest revision)
- Approved material submittals

GENERAL

Installation of Sprinkler and Fire Fighting Pipes and Fittings for the Podium and the Towers, shall be done in accordance with the project specifications and drawings.

EQUIPMENT

- Electric Pipe Cutter
- Threading Machine
- Grooving machine
- Welding machine
- Grinding Machine
- Chain Block
- Electric Drill and Extension Cable
- Pipe Wrenches & Spanners
- Spirit Level
- Plumb Bob
- Trolley
- Mobile Scaffolding and Aluminum 'A' Ladders

RESPONSIBLE PERSONNEL

- Project Manager
- Project Engineers
- Site Engineer/Site supervisor
- QA/QC Inspectors
- Safety officer
- Site Foremen

- Pipe Fitter
- Helpers

METHOD OF PRE INSTALLATION

11. Approved materials shall be purchased in accordance with the approved shop drawings and For Construction Contract Specifications.
12. Proper materials including pipes and fittings are to be selected and used according to approved shop drawing and good engineering practices.
13. Adequate stock of material, tools and tackles, testing equipments and consumables along with sufficient man power shall be arranged to carry out the work.
14. Prior to start of activity, area and access will be inspected to ensure that the area is ready for the work to start.
15. Ensure that all openings are in correct location and as per approved drawings.
16. Ensure that the construction power and water for testing of pipes are provided by the main contactor near to the work place
17. Safe and tidy work place, clear access to the work place, modes to shift material, tools and tackles etc are to be ensured.
18. Gauges used for testing to be calibrated.

INSTALLATION PROCEDURES

1. Ensure that all tools needed for Installation are ready.
2. Layout for Pipe Supports locations based on the approved drawings are by means of a chalk line to ensure straightness & run parallel to alignment of adjacent building surfaces.
3. Measure locations of Supports and drill concrete slab and fix anchor bolts, continuous thread rod and ring hangers.
4. Pipe Risers will be supported by means of angle supports anchored to the floor slab or shear wall with u-bolts, nuts and washers.
5. Cross mains will be supported by means of ring hangers with nuts and washers suspended continuous threaded rod anchored to the concrete ceiling slab.

6. Cross mains will also be supported by rigid supports using steel angles with u-bolts which will be anchored to the concrete ceiling slab.
7. Pipe work will rest freely on supports and aligned properly before final connection.
8. Valves and other in line equipment will be installed where indicated in the approved drawings and as per Manufacturer's recommendation.
9. Install Automatic Air Release Valve at high point of the system as required.
10. All Fire Stopping related works on Fire Protection sleeves are to be done by Main Contractor.
11. Pipe ends and Equipment to be covered with polyethelene cover ensuring that no dirt will go inside.

JOINTING METHOD:

1. By using Electric Pipe Cutter, cut the desired length of pipe to be joined and ensure the cut end of pipe is square and burr free.
2. For 65mm dia. and larger pipes, cut the pipe to suitable length and roll groove and bevel both ends by grooving machine.
3. For 50mm dia. and smaller, cut the pipe to suitable length and thread both ends by threading machine for fixing threaded fittings.
4. On threaded pipes apply Boss White and Teflon Tape, fix and tighten pipe and fitting using pipe wrenches.
5. Remove all dirt and moisture from pipe ends.

POST INSTALLATION PROCEDURE

3. Ensure to prepare As-Built Drawings as soon as possible after the work is completed.

QUALITY CONTROL

- QCE along with Project Engineer and site Supervisor will monitor that all components are installed as per the contract specifications and approved submittals.
- Inspection Request (IR) shall be submitted to the Main Contractor/Consultant during the following stages of work have been completed :-
 - Inspection of Piping installation and hydraulic testing

SAFETY

- Work will commence as per safety regulations laid down in the contract specification and project safety plan.
- Proper safety harness to be used and secured, if required.
- All personal protective equipment shall be used as appropriate according to the nature of job.
- Housekeeping shall be of good standard and all cut lengths and debris shall be removed.



Method Statement
Installation of Sprinklers

METHOD STATEMENT FOR INSTALLATION OF SPRINKLERS

SCOPE AND PURPOSE

This "Method Statement" covers the Installation of Sprinklers. This will also ensure workmanship and conforms to Contract documents.

REFERENCE DOCUMENTS

- Project Specifications
- Approved shop drawings (latest revision)
- Approved material submittals

GENERAL

Installation of Sprinklers shall be done in accordance with the project specifications and drawings.

EQUIPMENT

- Sprinkler Wrench
- Pipe Wrenches & Spanners
- Spirit Level
- Mobile Scaffolding and Aluminum 'A' Ladders

RESPONSIBLE PERSONNEL

- Project Manager
- Project Engineers
- Site Engineer/Site supervisor
- QA/QC Inspectors
- Safety officer
- Site Foremen
- Pipe Fitter
- Helpers

METHOD OF PRE INSTALLATION

1. Approved materials shall be purchased in accordance with the approved shop drawings and For Construction Contract Specifications.

2. Proper materials which include all types of Sprinklers are to be selected and used according to approved shop drawing and good engineering practices.
3. Adequate stock of material, tools and tackles, testing equipments and consumables along with sufficient man power shall be arranged to carry out the work.
4. Prior to start of activity, area and access will be inspected to ensure that the area is ready for the work to start.
 - ❖ Installed False Ceiling Grids is a pre-requisite for Pendent Sprinkler Droppers to be installed, without Ceiling reference Sprinkler Droppers cannot be installed.
 - ❖ Installed Bulk Head Frames is a pre-requisite for Sidewall Sprinklers to be installed.
 - ❖ Final Elevation of Air Grilles as per Site Condition is a pre-requisite for Sidewall Sprinklers to be installed.
5. Ensure that all openings are in correct location and as per approved drawings. Properly coordinated Approved Sprinkler Drawings and Approved Reflected Ceiling Plan Drawings is required
6. Ensure that construction power and water for testing of pipes are provided by the Main Contactor near to the work place.
7. Safe and tidy work place, clear access to the work place, modes to shift material, tools and tackles etc. are to be ensured.

INSTALLATION PROCEDURES

1. Ensure that all tools needed for Installation are ready.
2. Apply necessary Teflon Tapes and Shellac on the Sprinkler thread.
3. For Standard Upright and Pendent Sprinklers, mount the Sprinkler into the 25mm x 15mm reducer finger tight, after ensuring alignment; tighten by using Sprinkler Wrench and Pipe Wrench. Install Sprinkler Guard where required.
4. For Concealed Pendent Sprinklers, mount the Sprinkler into the 25mm x 15mm reducer finger tight, after ensuring alignment; tighten by using Sprinkler Wrench and Pipe Wrench.
5. For Sidewall Sprinklers, mount the Sprinkler (with the inner escutcheon plate in place) into the 25mm x 15mm reducer finger tight, then tighten by using Sprinkler Wrench and Pipe Wrench, ensure alignment by using Spirit Level mounted on the deflector.
 - After Sprinkler is properly installed wrap Sprinkler with masking tape to protect from being painted when Bulkhead and walls are painted.

6. Upon False Ceiling, Bulkheads and Walls are finally painted, Concealed Sprinkler Head Covers shall be installed and Sidewall Sprinklers wrapping shall be removed and install Wall Escutcheon plates.

JOINTING METHOD:

6. Remove all dirt and moisture from pipe ends.
7. Apply Teflon Tapes on Sprinkler thread, fix and tighten and by using Sprinkler Wrench and Pipe Wrench.

POST INSTALLATION PROCEDURE

4. Ensure to prepare As-Built Drawings as soon as possible after the work is completed.

QUALITY CONTROL

- QCE along with Project Engineer and site Supervisor will monitor that all components are installed as per the contract specifications and approved submittals.
- Inspection Request (IR) shall be submitted to the Main Contractor/Consultant during the following stages of work have been completed :-
 - Inspection of Piping installation and hydraulic testing

SAFETY

- Work will commence as per safety regulations laid down in the contract specification and project safety plan.
- Proper safety harness to be used and secured, if required.
- All personal protective equipment shall be used as appropriate according to the nature of job.
- Housekeeping shall be of good standard and all cut lengths and debris shall be removed.

Method Statement
Installation of Fire Hose Cabinets

METHOD STATEMENT FOR INSTALLATION OF ~~SPRINKLERS~~ FHC

SCOPE AND PURPOSE

This "Method Statement" covers the Installation of Fire Hose Cabinets. This will also ensure workmanship and conforms to Contract documents.

REFERENCE DOCUMENTS

- Project Specifications
- Approved shop drawings (latest revision)
- Approved material submittals

GENERAL

Installation of Fire Cabinets shall be done in accordance with the project specifications and drawings.

EQUIPMENT

- Hole Saw
- Electric Drill and Ext. Cable
- Spanners
- Pipe Wrenches & Spanners
- Spirit Level

RESPONSIBLE PERSONNEL

- Project Manager
- Project Engineers
- Site Engineer/Site supervisor
- QA/QC Inspectors
- Safety officer
- Site Foremen
- Pipe Fitter
- Helpers

METHOD OF PRE INSTALLATION

1. Approved materials shall be purchased in accordance with the approved shop drawings and For Construction Contract Specifications.

2. Proper materials which include all types of Sprinklers are to be selected and used according to approved shop drawing and good engineering practices.
3. Adequate stock of material, tools and tackles, testing equipments and consumables along with sufficient man power shall be arranged to carry out the work.
4. Prior to start of activity, area and access will be inspected to ensure that the area is ready for the work to start.
5. Ensure that all openings are in correct location and as per approved drawings.
6. Ensure that construction power and water for testing of pipes are provided by the Main Contactor near to the work place.
7. Safe and tidy work place, clear access to the work place, modes to shift material, tools and tackles etc. are to be ensured.

INSTALLATION PROCEDURES

1. Ensure that all tools needed for Installation are ready.
2. Drill the holes for fixing anchors and bolts. Ensure that the Bottom of the Cabinet is mounted 300mm above the finished floor.
3. Mount the Cabinet, ensuring vertical and horizontal alignments.
4. Mount the Fire Hose Reel into the Cabinet and connect the 25mm dia. Hose to the lock shield valve.
5. Wind the 25mm dia. Hose into the reel
6. Mount the Fire Rack into the Cabinet and connect the 65mm dia. Hose and Nipple to the Pressure Reducing Valve.
7. Hang the 65mm dia. Fire Hose and Nozzle in the Hose Rack properly.
8. Powder Fire Extinguishers beside the 65mm dia Fire Hose in the lower compartment of the Cabinet.

JOINTING METHOD:

1. Remove all dirt and moisture from pipe ends.

2. Apply necessary Boss White and Teflon tape on Threads and install the water supply pipe nipple, pressure reducing valve and lock shield valve by using pipe wrenches.

POST INSTALLATION PROCEDURE

1. Ensure to prepare As-Built Drawings as soon as possible after the work is completed.

QUALITY CONTROL

- QCE along with Project Engineer and site Supervisor will monitor that all components are installed as per the contract specifications and approved submittals.
- Inspection Request (IR) shall be submitted to the Main Contractor/Consultant during the following stages of work have been completed :-
 - a. Inspection of Piping Installation
 - b. Witness Hydrostatic Testing
 - c. Final Painting Touch-up

SAFETY

- Work will commence as per safety regulations laid down in the contract specification and project safety plan.
- Proper safety harness to be used and secured, if required.
- All personal protective equipment shall be used as appropriate according to the nature of job.
- Housekeeping shall be of good standard and all cut lengths and debris shall be removed.

Method Statement
Hydro-Static Testing of Sprinklers

01/01/2014

METHOD STATEMENT FOR HYDRO-STATIC TESTING OF SPRINKLER

SCOPE AND PURPOSE

This "Method Statement" covers the Hydro-static Testing of Sprinkler & Fire Fighting Piping Network. This will also ensure workmanship and conforms to Contract documents.

REFERENCE DOCUMENTS

- Project Specifications
- Approved shop drawings (latest revision)
- Approved material submittals

GENERAL

Hydro-static Testing of Sprinkler & Fire Fighting Piping Network shall be done in accordance with NFPA 13 & 14 requirements & Project Specifications & Drawings.

EQUIPMENT

- Pressure Pump
- Pressure gauge with Isolating Ball Valve
- Air Release Valve
- 25mm dia. Water Hose
- Aluminum 'A' Ladder & Complete Pipe Fitter's Tools

RESPONSIBLE PERSONNEL

- Project Manager
- Project Engineers
- Site Engineer/Site supervisor
- QA/QC Inspectors
- Safety officer
- Site Foremen
- Pipe Fitter
- Helpers

METHOD OF PRE INSTALLATION

1. Ensure that all Sprinkler & Fire Fighting Piping Networks are inspected and accepted by Consultant prior to

conducting Hydro-static Test.

2. Ensure all Equipment such as Pressure Pump, Tools and tackles, testing equipments and consumables along with sufficient Manpower shall be arranged to carry out the work.
3. Prior to start of activity, area and access will be inspected to ensure that the area is ready for the work to start.
4. Ensure all open ended pipes of the Piping Network to be Pressure tested shall be properly plugged. Install the Pressure Gauge, Air Release Valve and Isolating Ball Valve at the Remotest Point for Pressure reading and Flushing. Connect the Pressure Pump to the System
5. Connect the 25mm dia. Water Hose to the source of Water, with the Isolating Valve at the remotest open, fill the Piping Network with Water and flush the Piping Network until water is satisfactory clear.
6. Shut-off the Isolating Valve, remove the water hose and plug the valve.
7. Safe and tidy work place, clear access to the work place, modes to shift material, tools and tackles etc. are to be ensured.
8. Ensure that Pressure Gauges are calibrated with valid certificates.

INSTALLATION PROCEDURES

1. Ensure that all Equipment / Tools and Water are ready.
2. Fill up the Piping Network with Water, then with the use of the Pressure Pump slowly build up the pressure in the System and ensure trapped air is released thru the Air Release Valve. Check for leaks, inspect all Fittings while building-up the pressure.

Disconnect the Pressure Pump from Piping Network and keep away from Testing Area.

3. Repair leaks and defects, if any, and re-test the Piping Network as follows;
 - a. Low Pressure Line at 200 psi (13.8 bar) pressure for 2 hours.
 - b. High Pressure Line at 456 psi (31.4 bar) pressure for 2 hours.
4. Ensure that during Hydro-testing, calibrated Pressure Gauges are used as follows;
 - a. Range at 300 psi for low pressure line.
 - b. Range at 600 psi for high pressure line.
5. Pressure testing documentation shall be submitted along with Inspection request.

6. Fill up the Inspection Request and ensure that all Signatures above Names of Witnesses are taken after satisfactory result is completed.

QUALITY CONTROL

- QCE along with Project Engineer and site Supervisor will monitor that all components are installed as per the contract specifications and approved submittals.
- Inspection Request (IR) shall be submitted to the Main Contractor/Consultant during the following stages of work have been completed :-
 - d. Inspection of Piping Installation and Hydraulic Testing.

SAFETY

- Work will commence as per safety regulations laid down in the contract specification and project safety plan.
- Proper safety harness to be used and secured, if required.
- All personal protective equipment shall be used as appropriate according to the nature of job.
- Housekeeping shall be of good standard and all cut lengths and debris shall be removed.

Method Statement
Installation of Fire Alarm System

1111111111

METHOD STATEMENT FOR INSTALLATION OF FIRE ALARM SYSTEM

SCOPE AND PURPOSE

This "Method Statement" covers the site installation of Fire alarm system complete with all relevant devices and accessories and the requirements of checks to be carried out.

REFERENCE DOCUMENTS

- Project Specifications
- Approved shop drawings (latest revision)
- Approved material submittals

GENERAL

Fire alarm system integrated with voice alarm system include fire/smoke detection, smoke damper monitoring, emergency voice evacuation system with paging system and firefighter's emergency telephone system. It will be ensure that complete system shall meet the requirements of Local Civil Defence Authority Regulations.

EQUIPMENT

- Electrician hand tools
- Scaffoldings
- Nylon slings
- Measuring Tape
- Calibrated Megger

RESPONSIBLE PERSONNEL

- Project Manager
- Project Engineers
- Manufacturer's authorized representative
- Site Engineer/Site supervisor
- QA/QC Inspectors
- Safety officer
- Site Foremen
- Electrician
- Helpers

METHOD OF PRE INSTALLATION

1. Ensure that approved Materials are available to carry out the work.
2. Fire alarm system components with accessories received at site will be inspected as per approved material submittal. In case of any damage, the same should be brought to the notice of supplier for suitable resolution/replacement.
3. Physical verification of materials will be carried out for any damages prior to taking from stores and also prior to installation.
4. Prior to Commencement of work, areas and access will be inspected to confirm that Site is ready to commence the work.
5. All relevant documentation (Drawings and Materials) and Material applicable to particular section of work will be checked by site Supervisor prior to commencement of work.
6. The site Engineer/ site Supervisor will give necessary instructions to tradesmen (Electricians) and provide necessary approved construction/shop drawings.
7. The site Supervisor/Foremen will also check that proper tools and equipment are available to carry out the work and are in compliance with the contract specification.
8. The site Supervisor will also explain to the tradesmen regarding safety precautions to be observed.
9. The site Supervisor and QC Engineer will ensure that calibrated Megger is available at site for testing.

INSTALLATION PROCEDURES

1. General

All installations shall be carried out as per the Project specifications and CI/SS/FM the applicable wiring practices as per BS 5839

2. CABLE INSTALLATION

- 2.1 Ensure that cable containment (where applicable) as per approved shop drawing is installed, inspected and cleared for wire pulling.
- 2.2 Fire alarm cables will be directly cleated to soffit where there is no separate ELV containment is available in the areas covered by false ceiling, in private / core lobbies and car park areas.
- 2.3 Cable pulling through conduits from the drum end to the other end of the duct manually by using spring wire.
- 2.4 Ensure sufficient length of cable is maintained to connect to the device as per the approved shop drawings, before cutting the cable on both sides of conduit.

- 2.5 Upon completion of cable pulling. Inspection Request(IR) will be raised to Main contractor/Consultant.
- 2.6 Perform insulation resistance test for each segment of cable and ensure the continuity of all cable cores.

3. INSTALLATION OF FIELD DEVICES AND CONTROL PANEL

2.1 Manual call points, Smoke detectors, Heat detectors, Strobe light / Sounders:

- Install Manual call points as per approved construction drawings and manufacturer's instructions.
- Terminate cable to the device.
- Check the soundness of installation and alignment of devices.
- Device addressing by software using auto addressing feature. So separate labeling is not required. This will be carried by Manufacturer's authorized representative.

2.2 Monitor Module:

- Install Monitor Module as per approved construction drawings and manufacturer's instructions.
- Check the soundness of installation and alignment of the device.
- All the monitor modules to be installed near by the system from where it gets the input.
- Terminate the cabling to the device.

2.3 Line isolator and interface unit for flow switch:

- Install the device as per approved construction drawings and manufacturer's instructions.
- Terminate cable to the device.
- Check the soundness of installation and alignment of devices.

2.4 Fire alarm control panel:

- Check the control panel and its internal components before installation for any damage.
- Install the device as per construction drawings and manufacturer's instructions.
- Check the soundness of installation and alignment of panel.
- Check the battery and its terminals.
- Complete the Cabling terminations (except power supply and battery connection).
- Clean inside the control panel.

4. Power Separation:

- Fire detection cables shall not be placed along side power cables or share the same conduit, channel or sleeve with electrical apparatus.
- Cable runs shall be installed at least 450mm from the nearest source of electromagnetic interference.

5. Labelling :

- Labels for all cables will be attached according to the specifications. Concealed cabling, due to space restrictions will be tagged with device address at the termination end.

6. Cable Records:

- Correct conductor polarity shall be maintained during connection to devices.
- Identification at the Main fire Alarm Panel and associated connector blocks shall be in accordance with standard industrial Practices.
- Prepare as -built drawings after completion of installations to allow Commissioning team to work.

7. Cable Testing:

- All cables shall be insulation tested using calibrated instruments.
- Any defects in the cabling system installation shall be replaced in order to ensure complete performance under installed conditions.
- All test results shall be recorded as per the format given and shall be signed by Main contractor and consultant.

QUALITY CONTROL

- QCE along with Project Engineer and site Supervisor will monitor that all components are installed as per the contract specifications and approved submittals.
- Inspection Request (IR) shall be submitted to the Main Contractor/Consultant during the following stages of work have been completed :-
 - e. After completion of installation of Fire alarm cable for a particular area/section.
 - f. For testing of Fire alarm cables.
 - g. Installation of Field devices particular area or section of works.
 - h. Installation of Fire Alarm Panel.

SAFETY

- Work will commence as per safety regulations laid down in the contract specification and project safety plan.
- Proper safety harness to be used and secured, if required.
- All personal protective equipment shall be used as appropriate according to the nature of job.
- Housekeeping shall be of good standard and all cut lengths and debris shall be removed.
- Use of proper scaffolding while installing devices on soffit to be ensured.

Method Statement
Installation of Zone Control Valve Assembly

11-11-2013

METHOD STATEMENT FOR INSTALLATION OF ZONE CONTROL VALVE

ASSEMBLY

SCOPE AND PURPOSE

This "Method Statement" covers the Installation of Zone Control Valve Assembly. This will also ensure workmanship and conforms to Contract documents.

REFERENCE DOCUMENTS

- Project Specifications
- Approved shop drawings (latest revision)
- Approved material submittals

GENERAL

Installation of Zone Control Valve Assembly shall be done in accordance with the project specifications and drawings.

EQUIPMENT

- Chain Block
- Electric Drill
- Hole Saw and Extension Cable
- Pipe Wrenches & Spanners
- Torque Wrench
- Spirit Level
- Plumb Bob
- Trolley
- Mobile Tower Scaffolding & Aluminum "A" Ladders

RESPONSIBLE PERSONNEL

- Project Manager
- Project Engineers
- Site Engineer/Site supervisor
- QA/QC Inspectors
- Safety officer
- Site Foremen
- Pipe Fitter
- Helpers

METHOD OF PRE INSTALLATION

1. Approved materials shall be purchased in accordance with the approved shop drawings and For Construction Contract Specifications.
2. Proper materials such as Butterfly Valves, Water Flow Switches, Pressure Gauges, Isolating Gate Valves, Inspectors Test Connections & Drains including pipes and fittings are to be selected and used according to approved shop drawing and good engineering practices.
3. All material, tools and tackles, testing equipments and consumables along with sufficient man power shall be arranged to carry out the work.
4. Prior to start of activity, area and access will be inspected to ensure that the area is ready for the work to start.
5. Ensure that all openings are in correct location and as per approved drawings.
6. Ensure that the construction power and water for testing of pipes are provided by the Main Contactor near to the work place.
7. Safe and tidy work place, clear access to the work place, modes to shift.

INSTALLATION PROCEDURES

1. Ensure that all tools needed for Installation are ready.
2. Mount the Butterfly Valve on the grooved pipes and fix the couplings and then tighten the bolts and nuts by torque wrench.
3. Measure and mark then drill hole (by hole saw) where the Water Flow Switch is mounted then tighten the bolts & nuts by torque wrench.
4. Before mounting the switch clean inside pipe either side of hole.
5. Measure and mark then drill holes (by hole saw) where the outlet tee for the Inspector Test Connection piping is connected then tighten bolts & nuts by torque wrench. Apply Boss White and Teflon Tapes on the threads and install the Inspector Test Connection & Drain and Union.
6. Measure and mark then drill hole (by hole saw) where the outlet tee for the pipe nipple is connected then tighten bolts & nuts by Torque Wrench. Apply Boss White and Teflon Tapes on the pipe nipple threads and install the Isolating gate Valve and Pressure Gauge.

POST INSTALLATION PROCEDURE

1. Ensure to prepare As-Built Drawings as soon as possible after the work is completed.

QUALITY CONTROL

- QCE along with Project Engineer and site Supervisor will monitor that all components are installed as per the contract specifications and approved submittals.
- Inspection Request (IR) shall be submitted to the Main Contractor/Consultant during the following stages of work have been completed :-
 - i. Inspection of Piping Installation and Hydraulic Testing

SAFETY

- Work will commence as per safety regulations laid down in the contract specification and project safety plan.
- Proper safety harness to be used and secured, if required.
- All personal protective equipment shall be used as appropriate according to the nature of job.
- Housekeeping shall be of good standard and all cut lengths and debris shall be removed.

Method Statement
Installation of Pressure Reducing Valve Station

REVISION

METHOD STATEMENT FOR INSTALLATION OF PRESSURE REDUCING VALVE STATION

SCOPE AND PURPOSE

This "Method Statement" covers the Installation of Pressure Reducing Valve Station.. This will also ensure workmanship and conforms to Contract documents.

REFERENCE DOCUMENTS

- Project Specifications
- Approved shop drawings (latest revision)
- Approved material submittals

GENERAL

Installation of Pressure Reducing Station shall be done in accordance with the project specifications and drawings.

EQUIPMENT

- Grinding Machine
- Chain Block
- Electric Drill and Extension Cable
- Pipe Wrenches & Spanners
- Torque Wrench
- Spirit Level
- Plumb Bob
- Trolley
- Grooving Machine

RESPONSIBLE PERSONNEL

- Project Manager
- Project Engineers
- Site Engineer/Site supervisor
- QA/QC Inspectors
- Safety officer
- Site Foremen
- Pipe Fitter
- Helpers

METHOD OF PRE INSTALLATION

8. Approved materials shall be purchased in accordance with the approved shop drawings and For Construction Contract Specifications.
9. Proper materials such as PRV's, OS&Y Gate Valves, Pressure Gauges, Isolating gate valves including pipes and fittings are to be selected and used according to approved shop drawing and good engineering practices.
10. All material, tools and tackles, testing equipments and consumables along with sufficient man power shall be arranged to carry out the work.
11. Prior to start of activity, area and access will be inspected to ensure that the area is ready for the work to start.
12. Ensure that all openings are in correct location and as per approved drawings.
13. Ensure that the construction power and water for testing of pipes are provided by the Main Contactor near to the work place.
14. Safe and tidy work place, clear access to the work place, modes to shift.

INSTALLATION PROCEDURES

9. Ensure that all tools needed for Installation are ready.
10. Mount the Gate Valve on the flange with the gasket and all bolts in place then tighten all nuts by fingers.
11. Mount the pipe Spool with pipe nipple for Pressure Gauge with the gasket and all bolts in place then tighten nuts by fingers.
12. Mount the Pressure Reducing Valve on the flange with the gasket and all bolts in place then tighten nuts by fingers.
13. Mount the Pipe Spool with Pipe nipples for pressure gauge and safety relief valve with gasket and all bolts in place then tighten nuts by fingers.
14. Install the By-pass by repeating items 2 to 5.
15. Tighten all bolts and nuts alternately to ensure alignment by using a torque wrench.

16. Apply Boss White and Teflon Tapes on pipe nipples and install Isolating Valves and Pressure Gauges and Pressure Relief Valve.
17. Support the Pressure Reducing Station properly as specified.

POST INSTALLATION PROCEDURE

5. Ensure to prepare As-Built Drawings as soon as possible after the work is completed.

QUALITY CONTROL

- QCE along with Project Engineer and site Supervisor will monitor that all components are installed as per the contract specifications and approved submittals.
- Inspection Request (IR) shall be submitted to the Main Contractor/Consultant during the following stages of work have been completed :-
 - a. Inspection of Piping Installation and Hydraulic Testing

SAFETY

- Work will commence as per safety regulations laid down in the contract specification and project safety plan.
- Proper safety harness to be used and secured, if required.
- All personal protective equipment shall be used as appropriate according to the nature of job.
- Housekeeping shall be of good standard and all cut lengths and debris shall be removed.

Building Automation ,Networking & Communication

We are Interested to visit and meet Electrical , MEP Consultants Building Infra Developers, Solar Power Developers and Solar Project Handling EPC Companies .

Link Vue System is Known Professional Team of Technical believes on Offering Genuine and Right Products.(www.linkvuesystem.com)

We Offer Design Engineering Supply and Installation Supports by Professionals

Scope Of Products

Earthing for DC Arrays

Surge Protection Devices

MC 4 Connectors with and Without Fuses

Networking LAN Fiber , Wireless and GSM Solutions, Liu's Patch Cord

Smart Data Loggers , Protocol Converters , Protocol to FO Converters

Lithium Battery Package for High Energy Storage System

Weather Monitoring Stations

DRONE Survey for Project and Maintenance of Panel Health

CCTV ,Fire Alarm ,Access Controls , Security Systems, PIDS Fencing ,Smart Parking Management Solution.

AMC for Above

Special Project for Electric Vehicles

Connectors CCS ,GBT and CHAdeMO ,

Cables for Electric Vehicles

Cable Harness for Electric Vehicle's and Charging UNIT.

Electric Vehicle Charger 3KW -250KW AC Charging , DC Charging

CAE Power Connectors 16Amps -400 Amps

Free Dom Connectors for Low Voltage Cables

Plz Confirm your Availability and Place for meeting in Advance

Mail : manav.chandra@linkvuesystem.com , manish@linkvuesystem.com

Sydney Australia

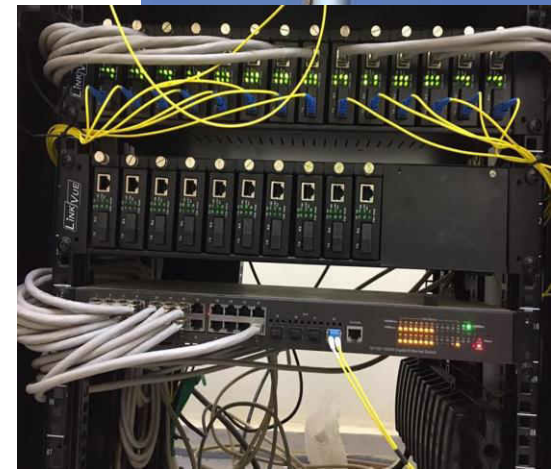

Right Solution Partner for your Problems A Genuine Approach Latest Technologies Adoption

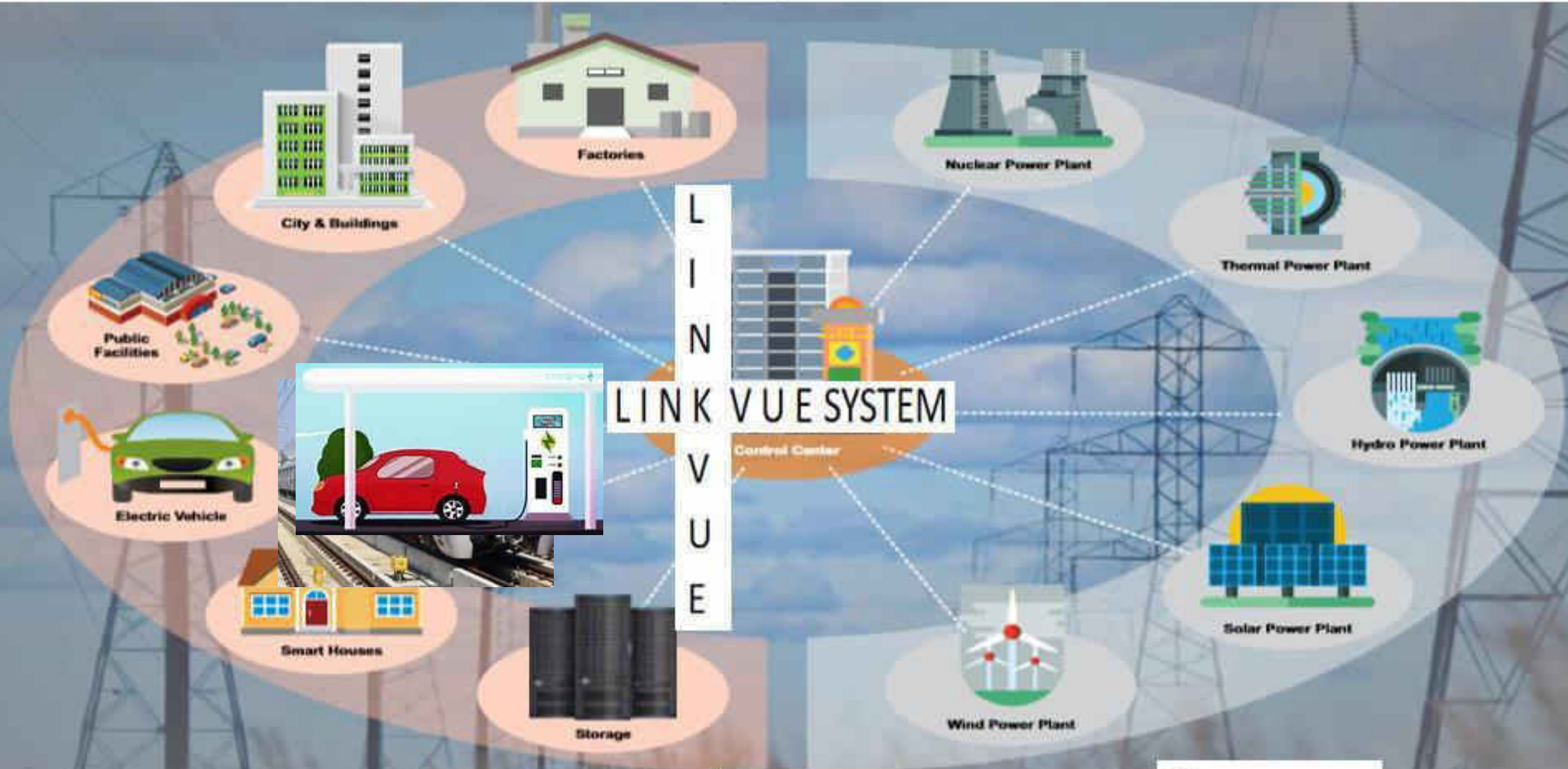

Australia

India

Singapore

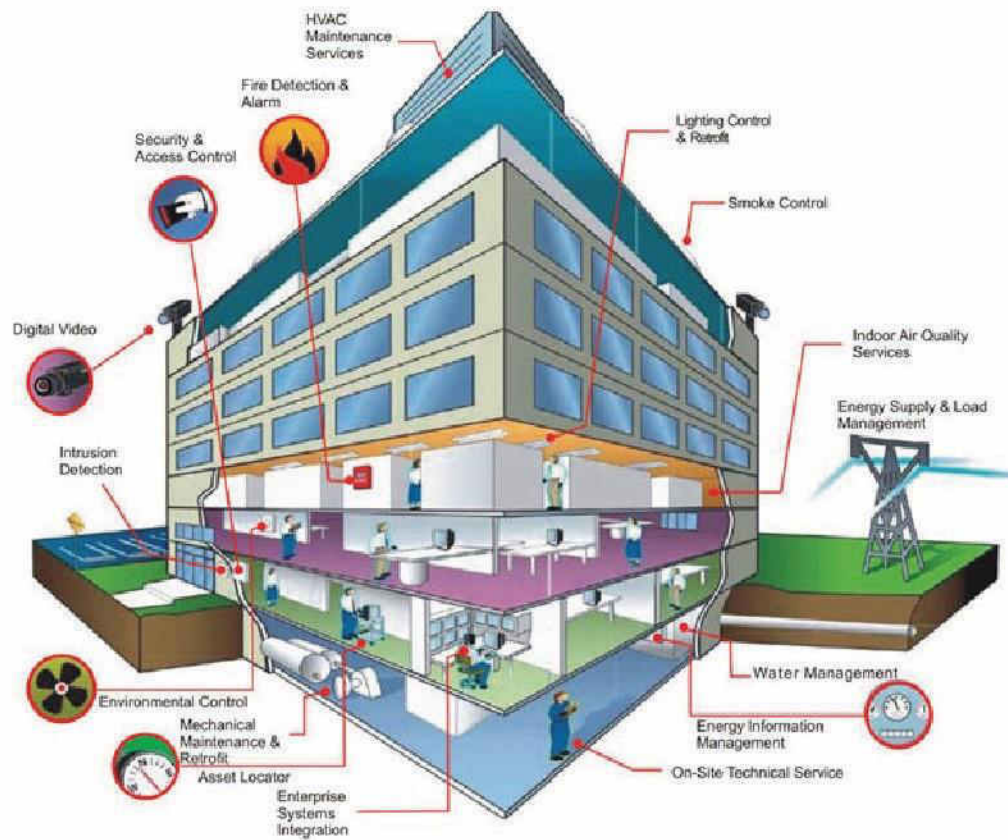

Link Vue System Pvt Ltd

Electrical Safety

Earthing, Lightning & Surge Protection

Net Working Product Supply & Installation

Ethernet SW, Fiber Optics & Wire Less

Automation Products

**Data Logger, RTU's Digital & Analog I/O's
Protocol Converter, Media Converter,
Cables Connectors & LIU's
Perimeter Intrusion Detection System CCTV,
Fire Alarm, Access Controls & Security System
Cable & Connectors, Plug & Sockets for
Electrical Vehicles, Solar PV, Building Wiring**

**I
N
D
I
A**

**A
U
S
T
R
A
L
I
A**



Our Mission

To provide finest security services and customized innovative solutions through our extensive complement of high quality products and services, we will enable our clients to run their operations with minimal effort and concern for their safety and security.



Our Vision

To be the best in class by creating long-term strategic relationship with our clients and leveraging our technological acumen and industry expertise to provide innovative , quality and cost effective solutions. To attract, engage, develop and retain the best talent and to create an environment in which our employees grow personally and professionally"



Our Goal

To become a leader in the technological edge to improve organizational security, profitability & Reliability through intelligent office automations, quality control automations, biometrics and security solutions!

Dedication: We are continuously committed towards serving our customers. All our employees have full allegiance towards our motto 'customer comes first'

Performance: We believe in continuously raising the bar of performance, allowing us to meet and exceed client expectations every time.

Integrity: We walk the talk, delivering what we promise. We stand by our commitments providing our customers utmost satisfaction.

Teamwork: We believe in working together, staying together. We encourage open and effective communication and interaction. Our organizational culture patronizes unfettered and integrated teamwork among different departments allowing seamless, fruitful operations.

Transparency: We work with lucid thoughts and actions, ensuring equality among our employees, customers and suppliers.

Accountability: We take responsibilities for our decisions and actions. We allow our empowered employees to honour their commitments and do what is necessary to gratify our clients and meet the organizational goals and objectives

Power Supply is very Important for all Infrastructure

SMART GRID

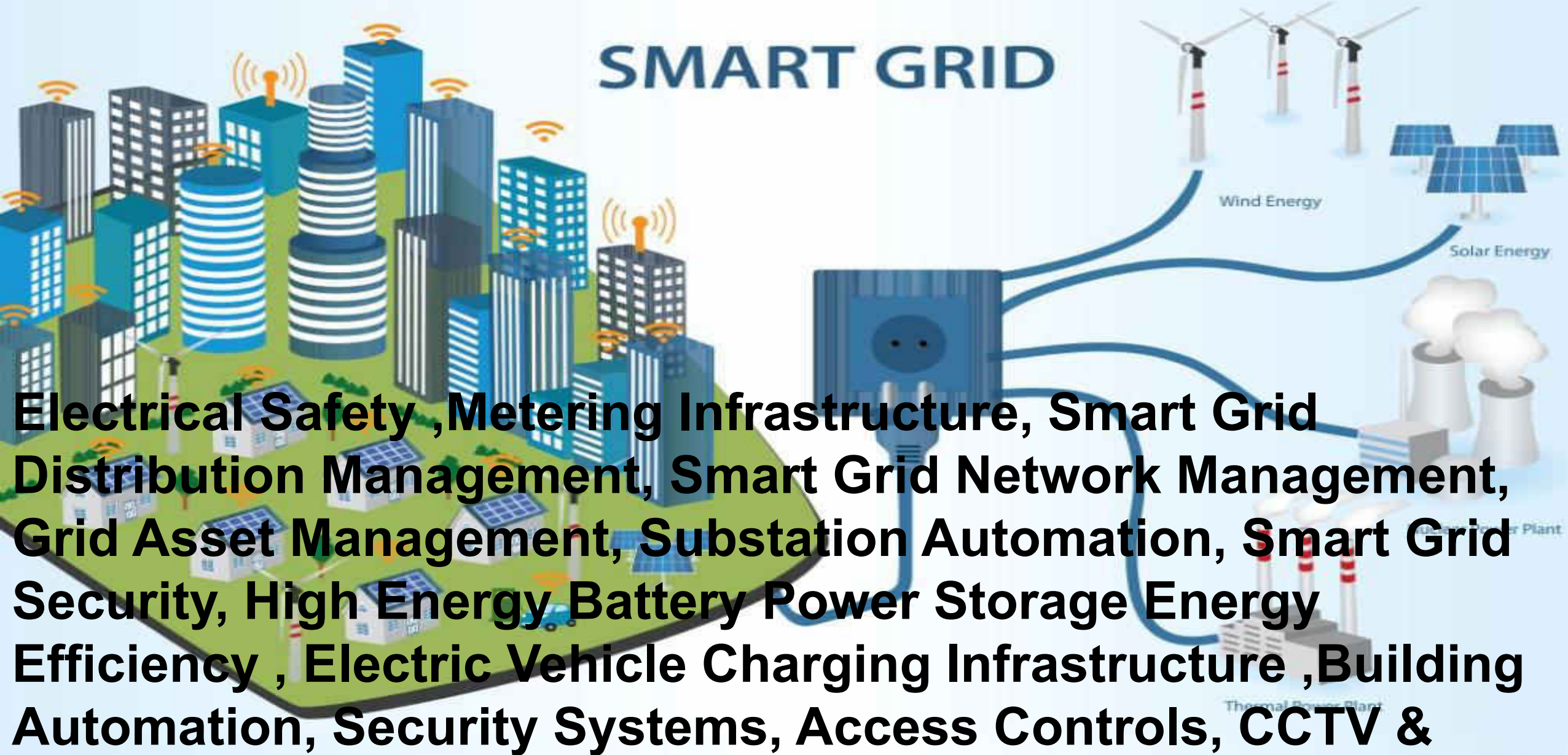

Electrical Safety , Metering Infrastructure, Smart Grid Distribution Management, Smart Grid Network Management, Grid Asset Management, Substation Automation, Smart Grid Security, High Energy Battery Power Storage Energy Efficiency , Electric Vehicle Charging Infrastructure , Building Automation, Security Systems, Access Controls, CCTV &

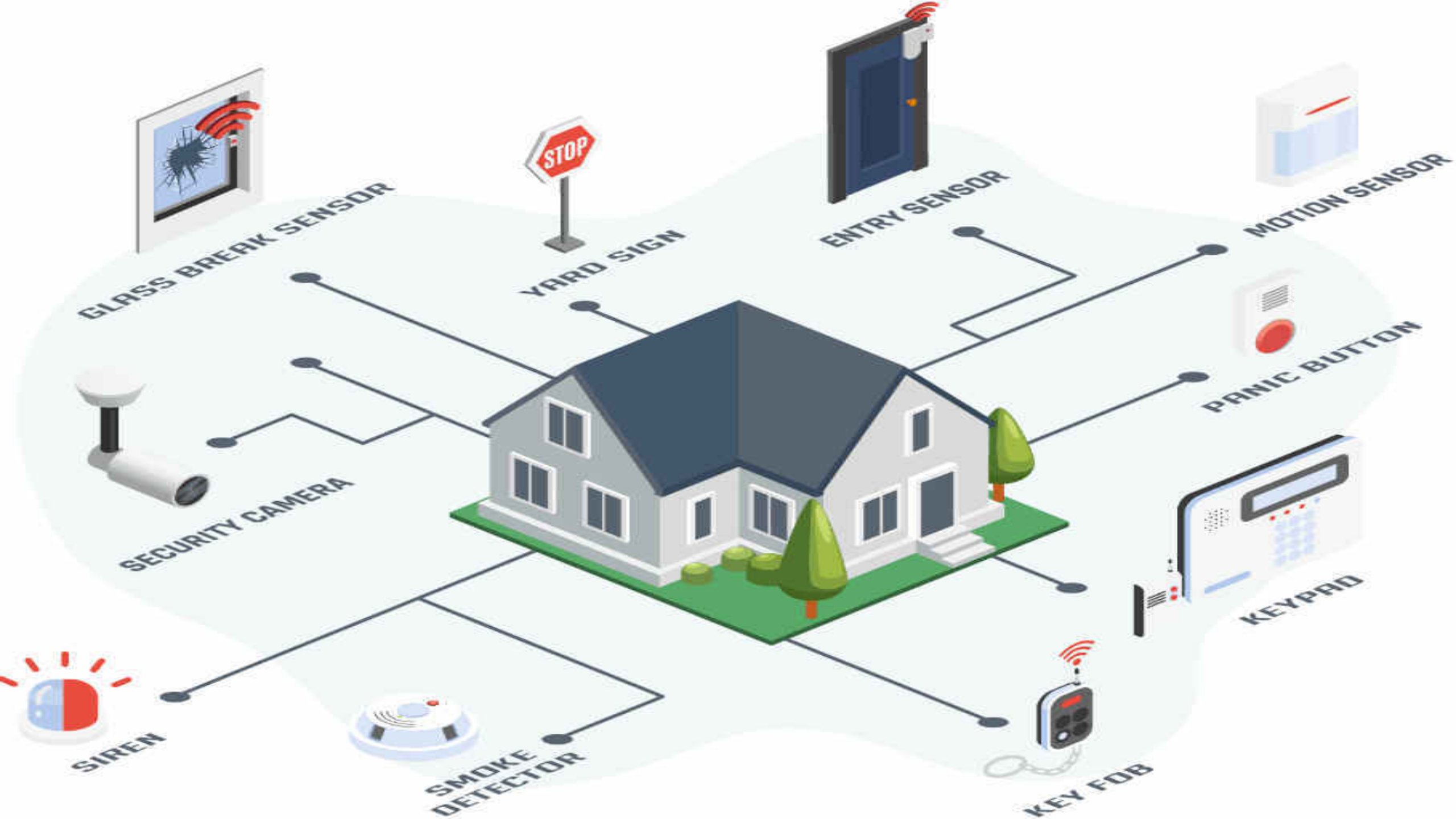

With Link-vue Freedom to Monitor ,Access and Control Remotely

Take your equipments online

The next generation IIoT platform



marc is our next generation GSM/LAN based IIoT platform with built in apps for assets and equipment for managing efficiency, uptime, productivity, condition monitoring, control, preventive & predictive maintenance.

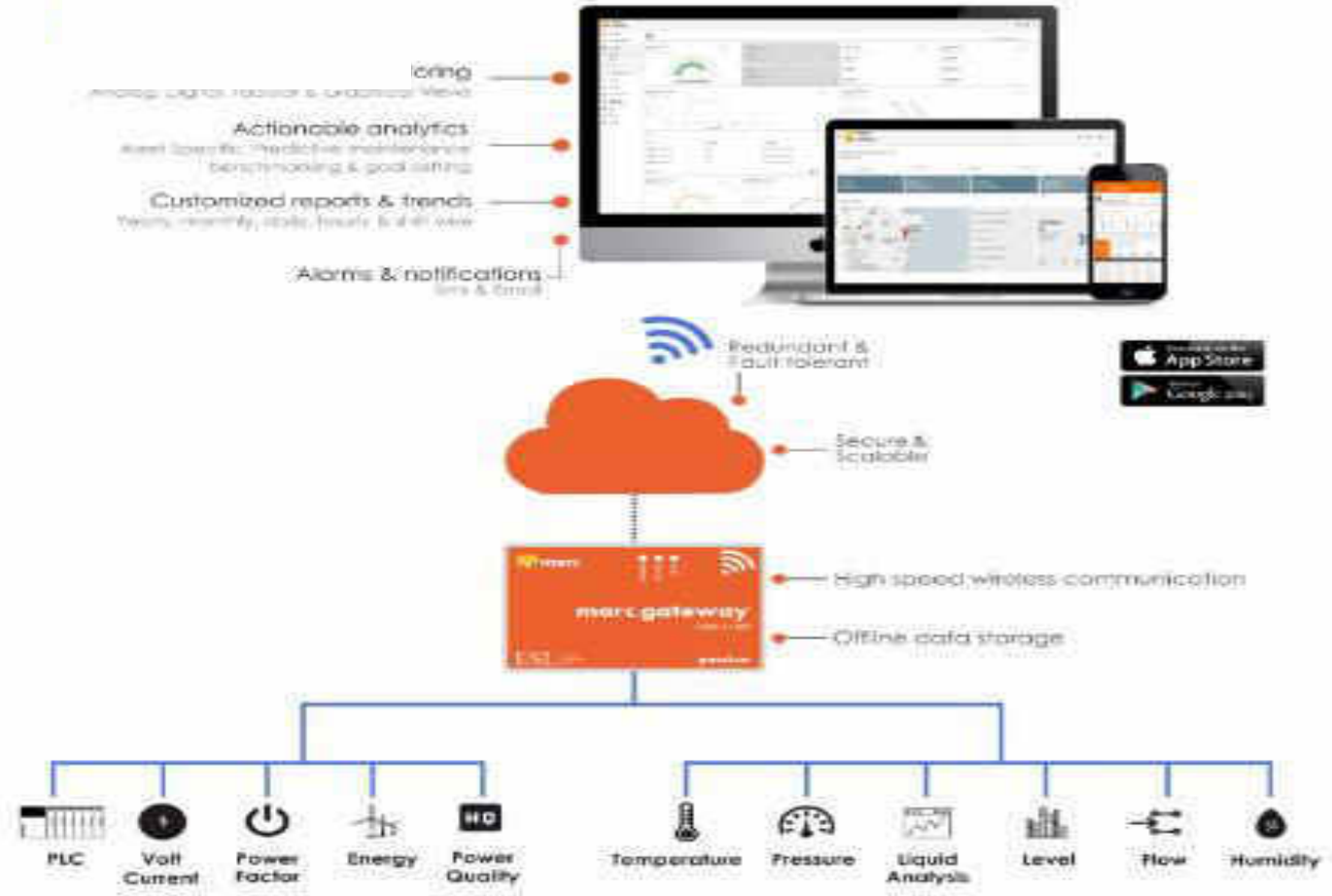

Supported Protocols - Modbus TCP/IP, Modbus RTU, MQTT, Https

Applications		Why IIoT?
Energy & Utility <ul style="list-style-type: none"> Energy Management Transformer Monitoring Industrial Motor NVAC Monitoring Solar Energy 	Plant & Process <ul style="list-style-type: none"> Equipment or Asset Monitoring Process Monitoring Machine Monitoring OEE Other Agriculture, Vehicle Weather Smart City Custom Application development 	<ul style="list-style-type: none"> Efficiency Uptime Productivity Availability Service Condition Alert Prevention Prediction
Audit <ul style="list-style-type: none"> Energy Audit Water Management Water Audit 		

Link Vue System Offer Safety for Human and Assets (ALERT 24X7)

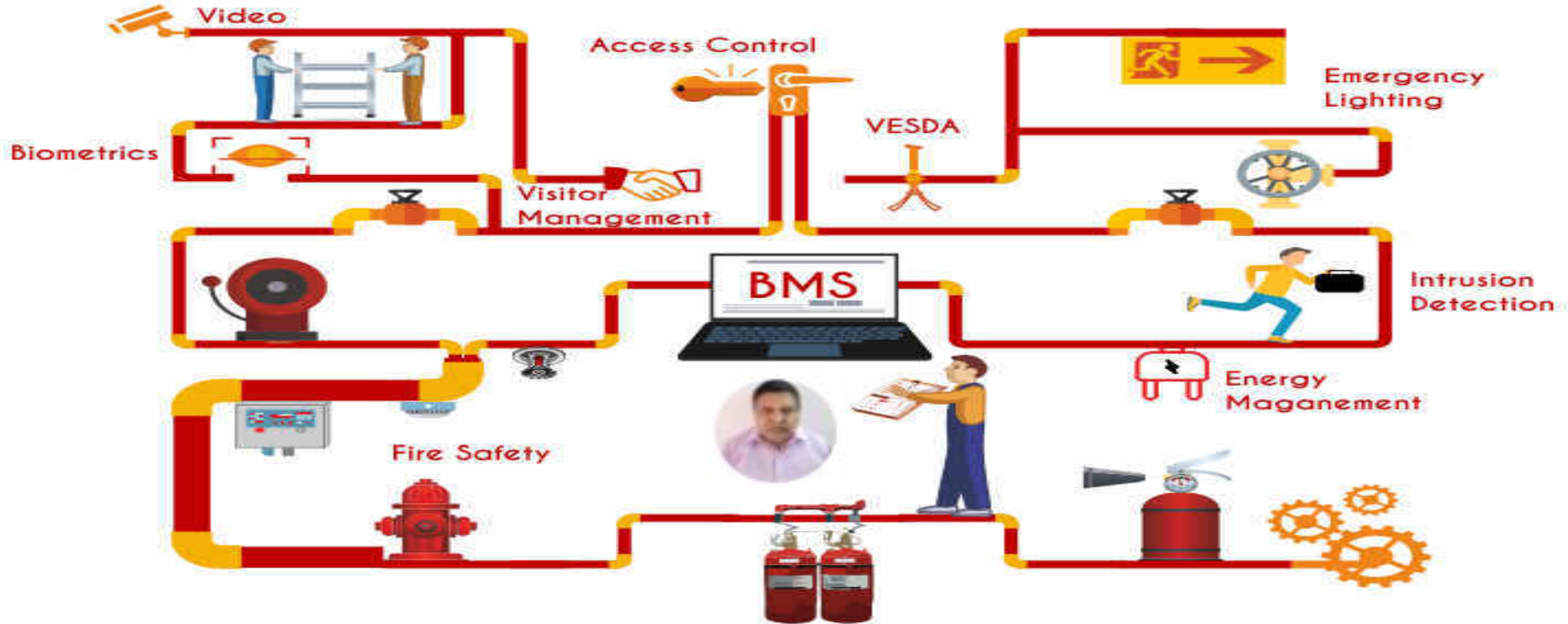

One Stop Solution for
FIRE SAFETY, SECURITY & IBMS

DAY NIGHT 24X7 Monitor Solar PV Plant Through CCTV Network

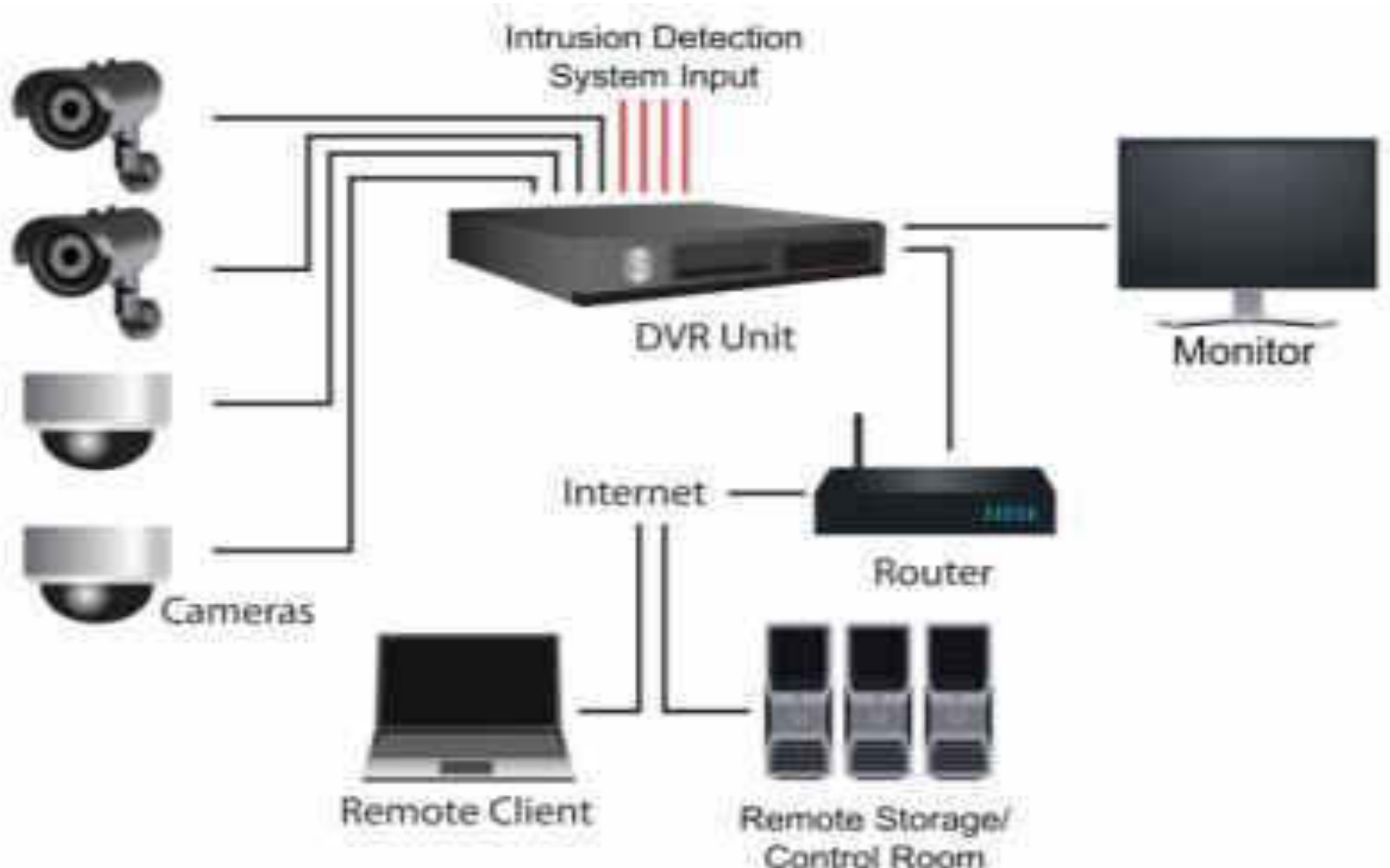

CCTV Installation for Indoor & outdoor

IP Based Surveillance Camera Systems

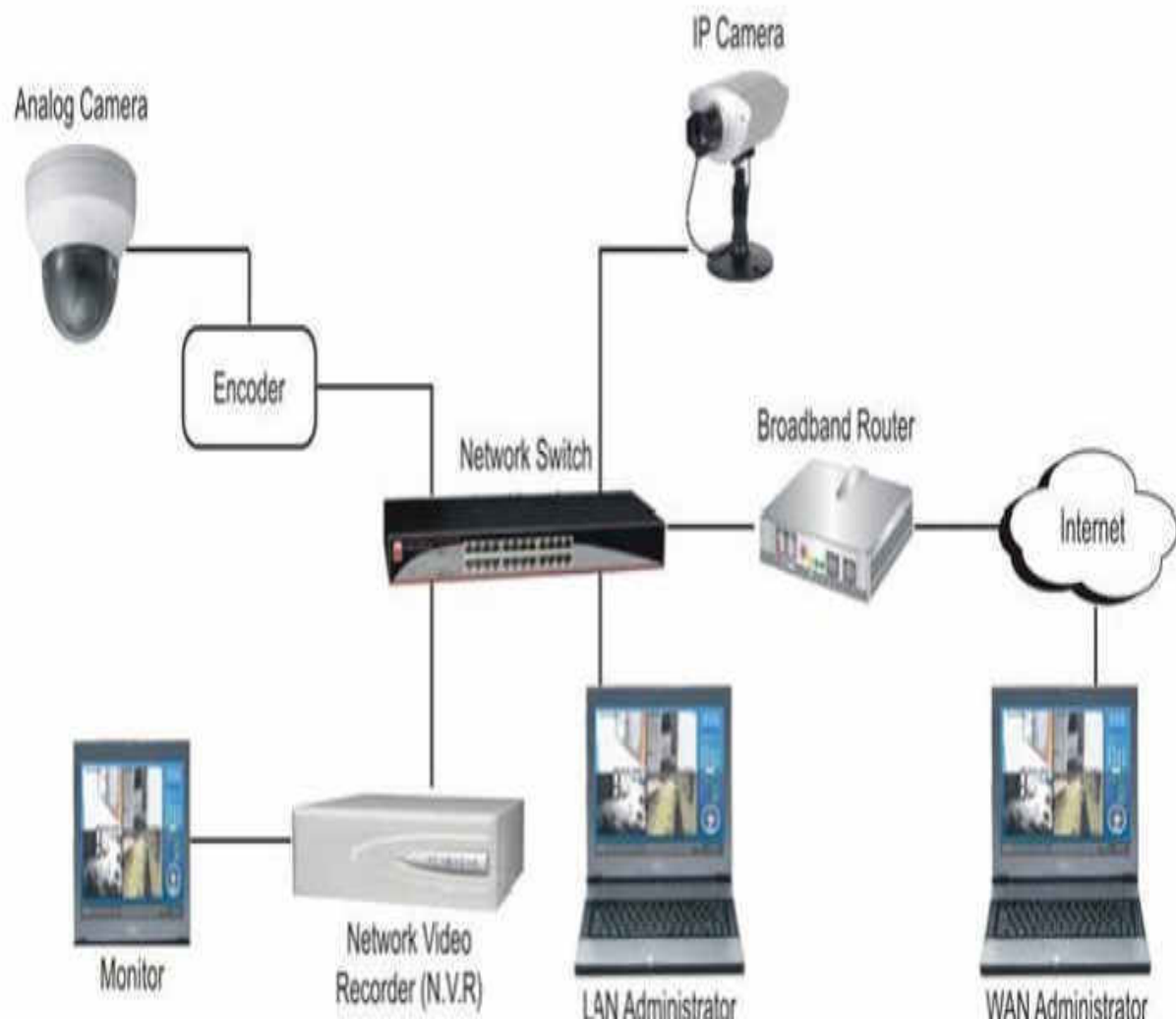

Surveillance is the monitoring of behaviour, many activities, or information for the purpose of information gathering, influencing, managing or directing. This can include observation from a distance by means of electronic equipment, such as closed-circuit television (CCTV), or interception of electronically transmitted information like Internet traffic. It can also include simple technical methods, such as human intelligence gathering and postal interception.

Surveillance is used by citizens for protecting their neighbourhoods. And by governments for intelligence gathering - including espionage, prevention of crime, the protection of a process, person, group or object, or the investigation of crime. It is also used by criminal organizations to plan and commit crimes, and by businesses to gather intelligence on criminals, their

Addressable Fire Alarm System

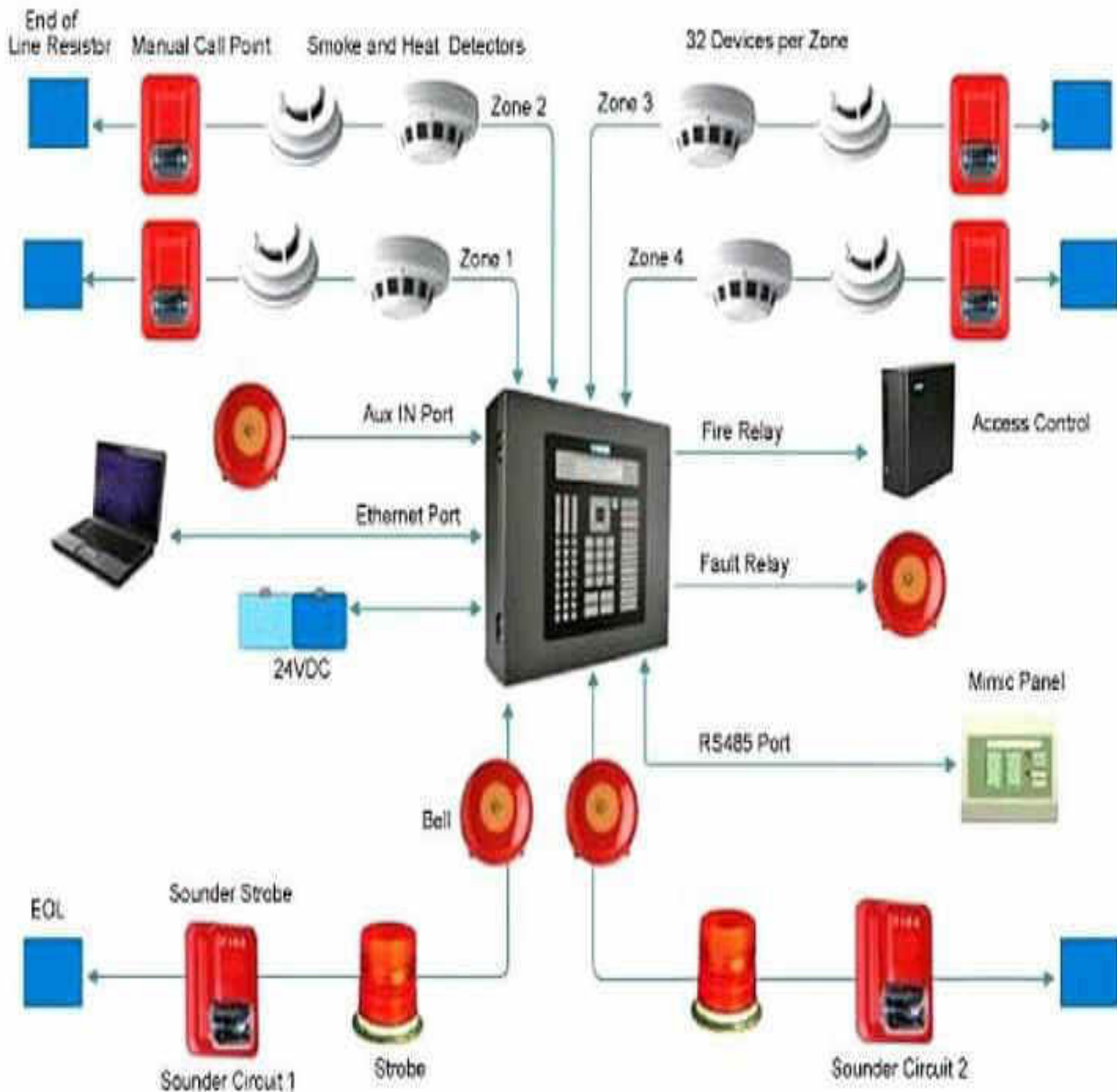

Provides Conventional and Addressable Fire Alarm and Detection system to warn and help people when smoke, fire, carbon monoxide or other fire-related emergencies are detected. These alarms may be activated automatically from smoke detectors, and heat detectors or may also be activated via manual fire alarm activation devices such as manual call points or pull stations. Alarms can be either motorized bells or wall mountable sounders or horns. They can also be speaker strobes which sound an alarm, followed by a voice evacuation message which warns people inside the building not to use the elevators. Fire alarm sounders can be set to certain frequencies and different tones including low, medium and high, depending on the country and manufacturer of the device. Most fire alarm systems in Europe sound like a siren with alternating frequencies. Fire alarm electronic devices are known as horns in the United States and Canada, and can be either continuous or set to different codes.

Public Address Systems for Intelligent Buildings Management

16 Zone IP PA System with BGM/Zone Paging with Zone Monitoring

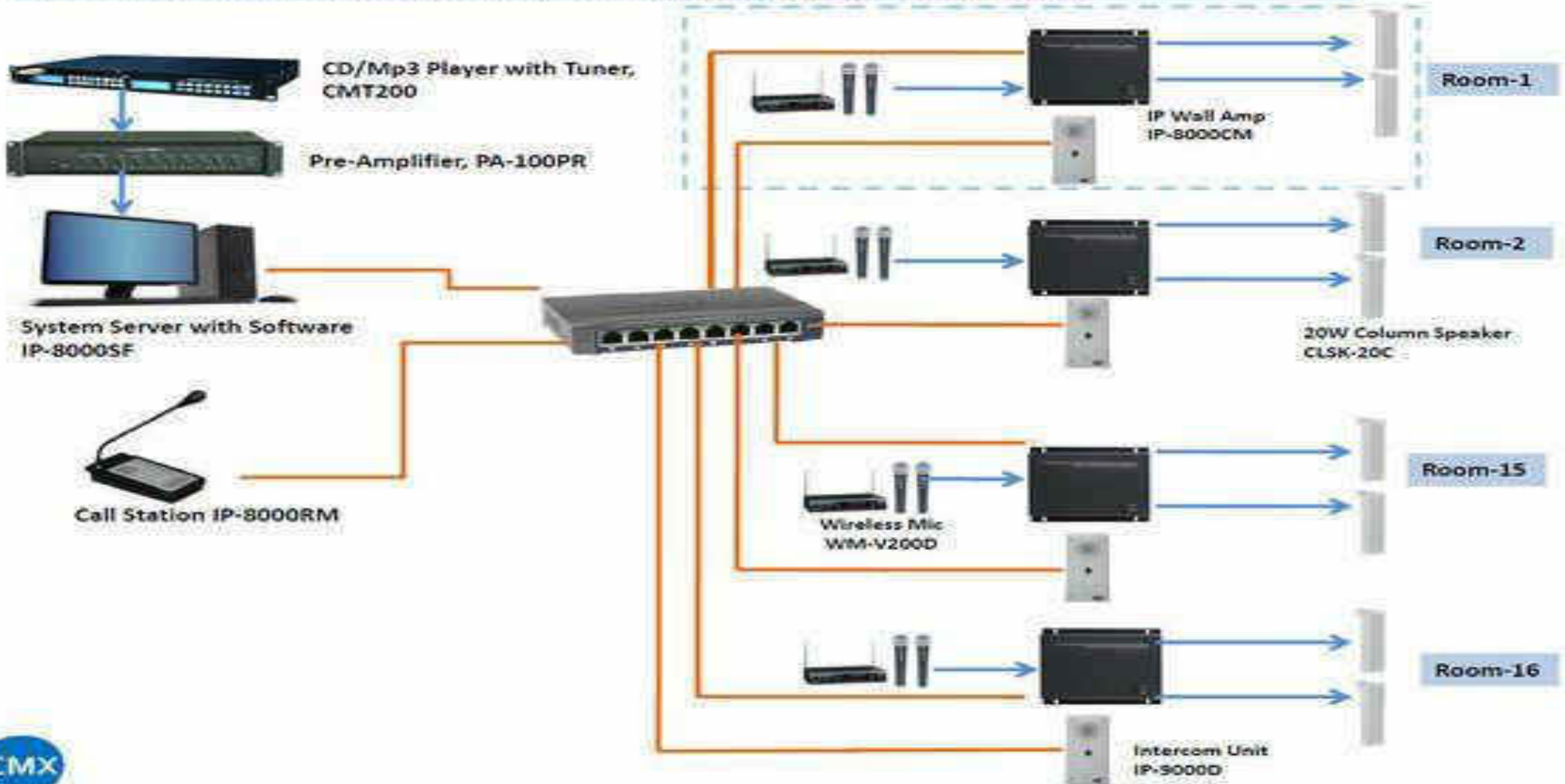

Public Address Systems

PA system is an electronic system comprising microphones, amplifiers, loudspeakers, and related equipment. It increases the apparent volume (loudness) of a human voice, musical instrument, or other acoustic sound source or recorded sound or music. PA systems are used in any public venue that requires that an announcer, performer, etc. be sufficiently audible at a distance or over a large area. Typical applications include sports stadiums, public transportation vehicles and facilities, and live or recorded music venues and events. A PA system may include multiple microphones or other sound sources, a mixing console to combine and modify multiple sources, and multiple amplifiers and loudspeakers for louder volume or wider distribution.

Simple PA systems are often used in small venues such as school auditoriums, churches, and small bars. PA systems with many speakers are widely used to make announcements in public, institutional and commercial buildings and locations—such as schools, stadiums, and passenger vessels and aircraft.

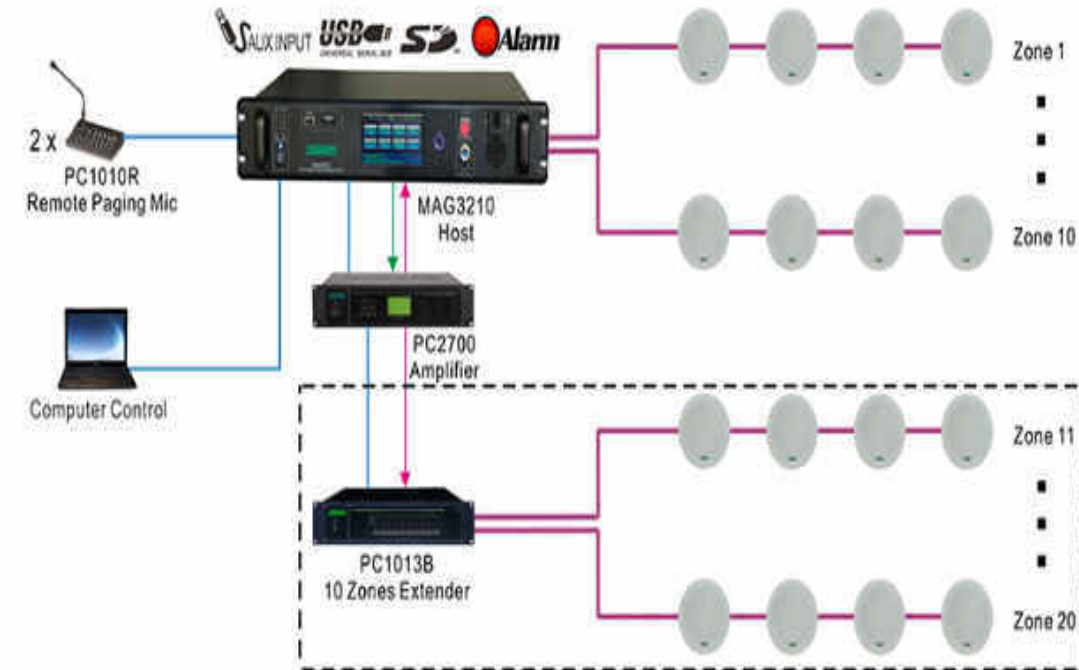

Parking Management Systems

Parking Management System

Brothers Secure Provides a parking management system automates a car parking system. It optimizes parking space and make processes efficient. It gives real-time car parking information such as vehicle & slot counts, available slots display, reserved parking, pay-and-park options, easy payments, reports, and a host of other features.

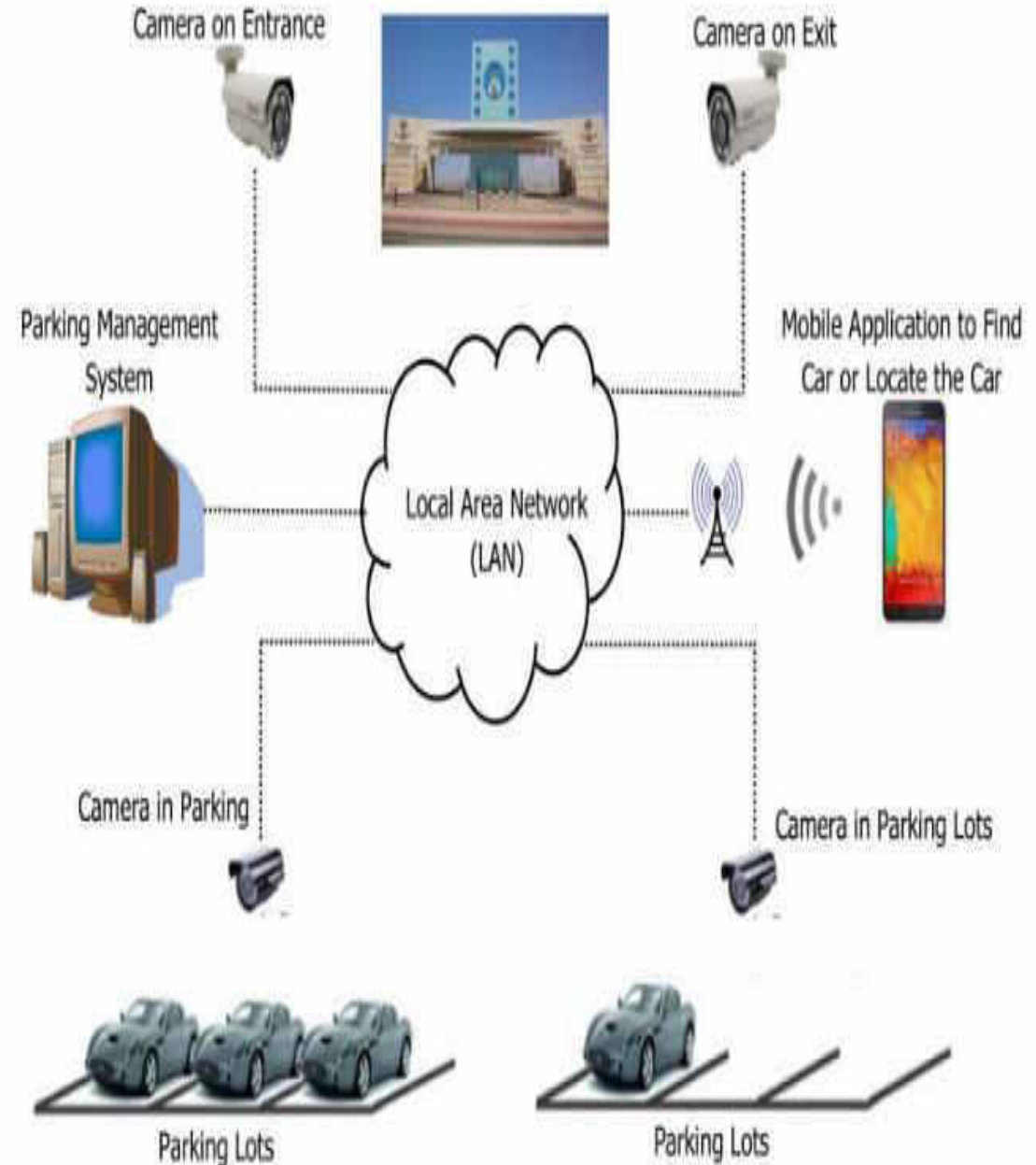

Access Control Systems

Ip access control systems

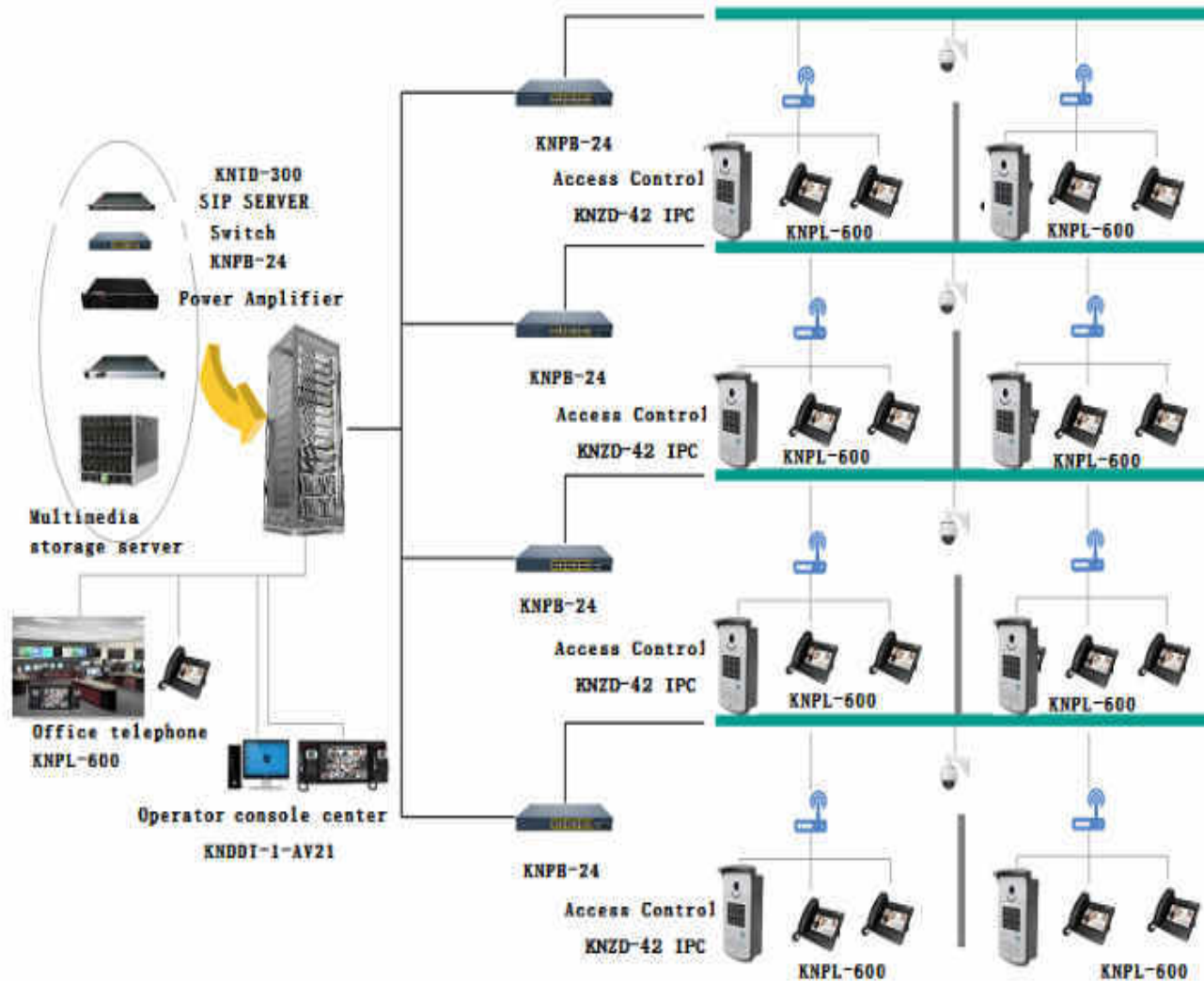

Access control systems which is electronic systems that facilitate automated approval for authorized personnel to enter through a security portal without the need for a security officer to review and validate the authorization of the person entering the portal, typically by using a credential to present to the system to verify their authorization. A security portal is a door or passageway that creates an entry point in a security boundary. Access control systems are based on the premise that issuing keys to all employees who need them is generally not cost-effective. Another premise of an access control system is that it would be cost prohibitive to rekey the facility should a key be lost. Finally, an access control system can limit employee access; allowing them entry only to areas in which they are authorized, or granting entry during certain times of day. An access control system uses a means of verification, known as a credential, to allow a person to enter an area. The credential can be something that is known, generally a personal identification number; something that is carried, such as a card or token; or something that the authorized person has, such as a fingerprint or iris (the coloured part of the eye). The credential is entered, swiped, presented, or scanned, and, after some level of verification, access is granted or denied.

BMS

HVAC

Chillers/Heat Pumps
Air Handling Units
VAV Systems
VRF Systems
Precision ACs
Ventilation & Exhaust
Kitchen Exhaust
BTU Metering
Tenant Billing

Electrical

Energy Metering
Elevators
HT/LT Panels
Transformers
EPMS
Lighting Management
UPS & Battery

PHE

Fire Fighting
STP/WTP
PHE Pumps
Chemical Dosing
Water Tanks
Water Meters
RO Systems

3rd Party Systems

Fire Alarm Systems
Security Systems
VESDA System
Basement Vent System
BTU Meters
Water Leak Detection
Rodent Repellent Systems

Through Hardwiring and Soft Integration

ARCHITECTURE FOR BUILDING MANAGEMENT SYSTEM

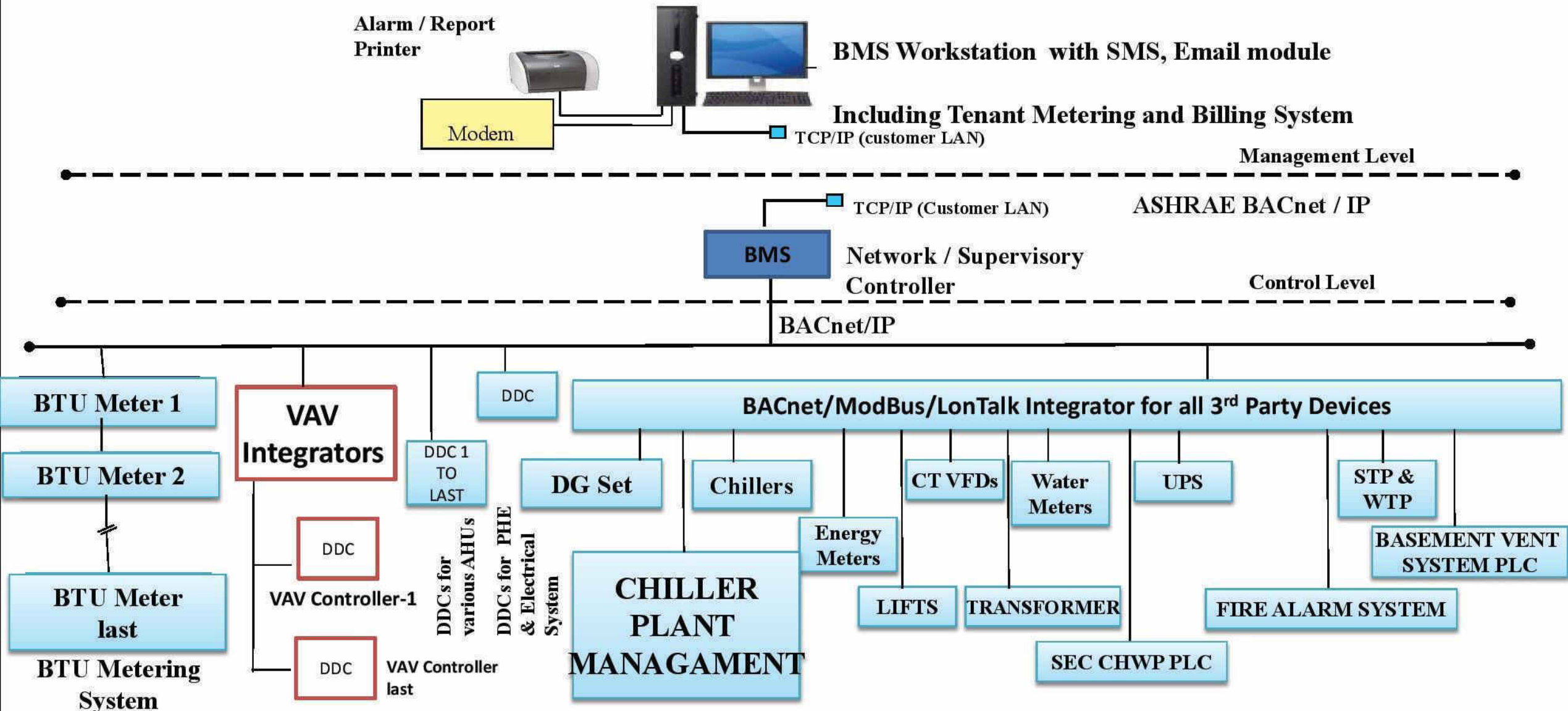

DRAWING: BMS Architecture

DATE:

REV : 0

BMS System Architecture

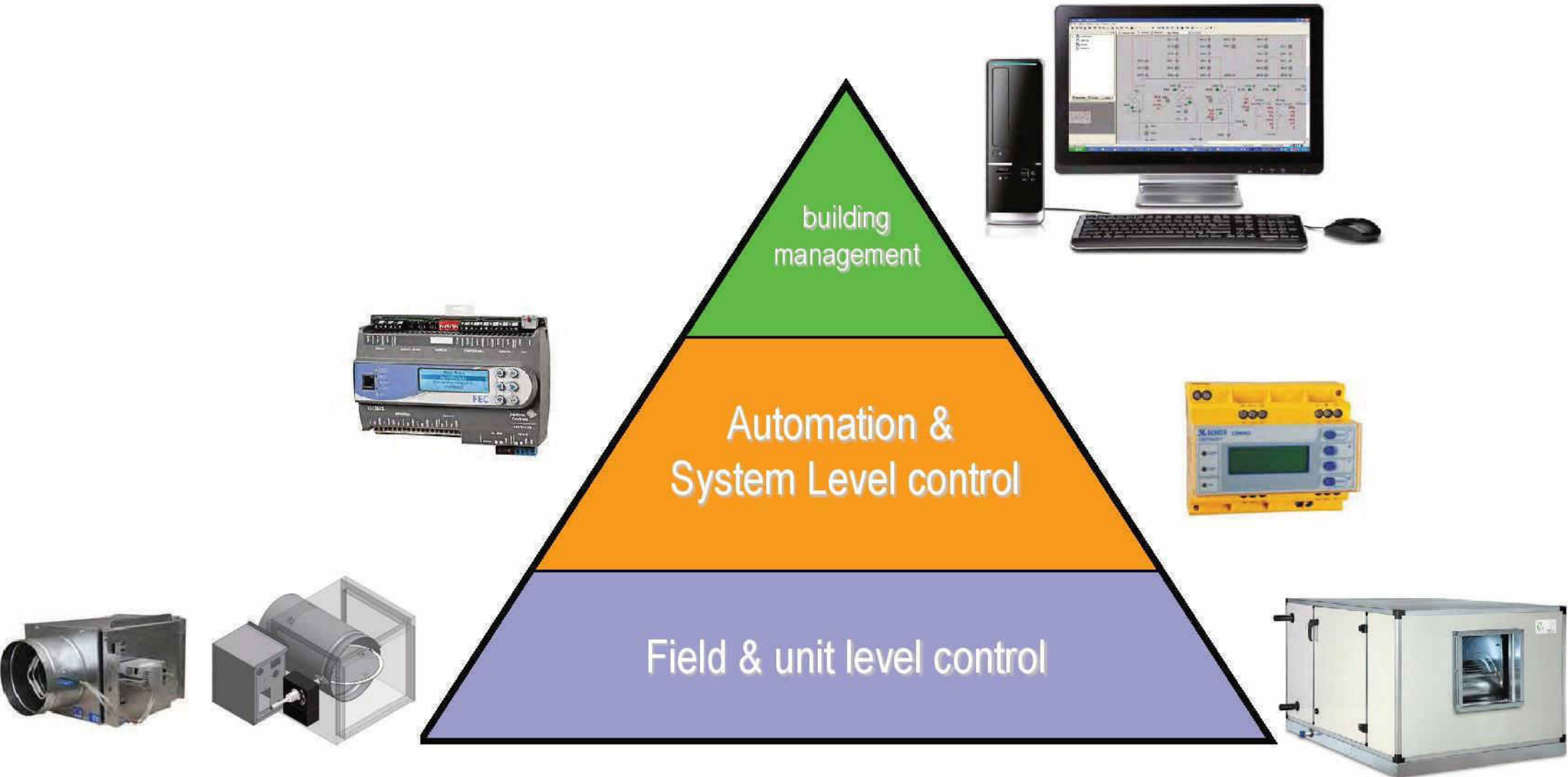

- **Centralized WorkStation Computer**

- With powerful user-friendly software.
- Used for everyday building operation.

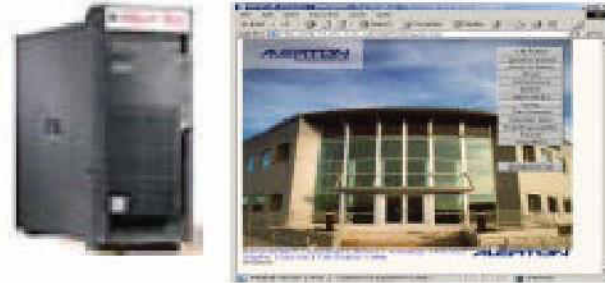

- **DDC Controllers**

- Micro-processor based
- Pre-configured / Freely programmable
- Controls the HVAC equipment of the building and other electromechanical equipment



- **Field devices**

- Temperature, Humidity, Pressure sensors
- Valves, Actuators



Typical System Components – Field Devices & DDCs

What Does Intelligent Microprocessor Control Mean?

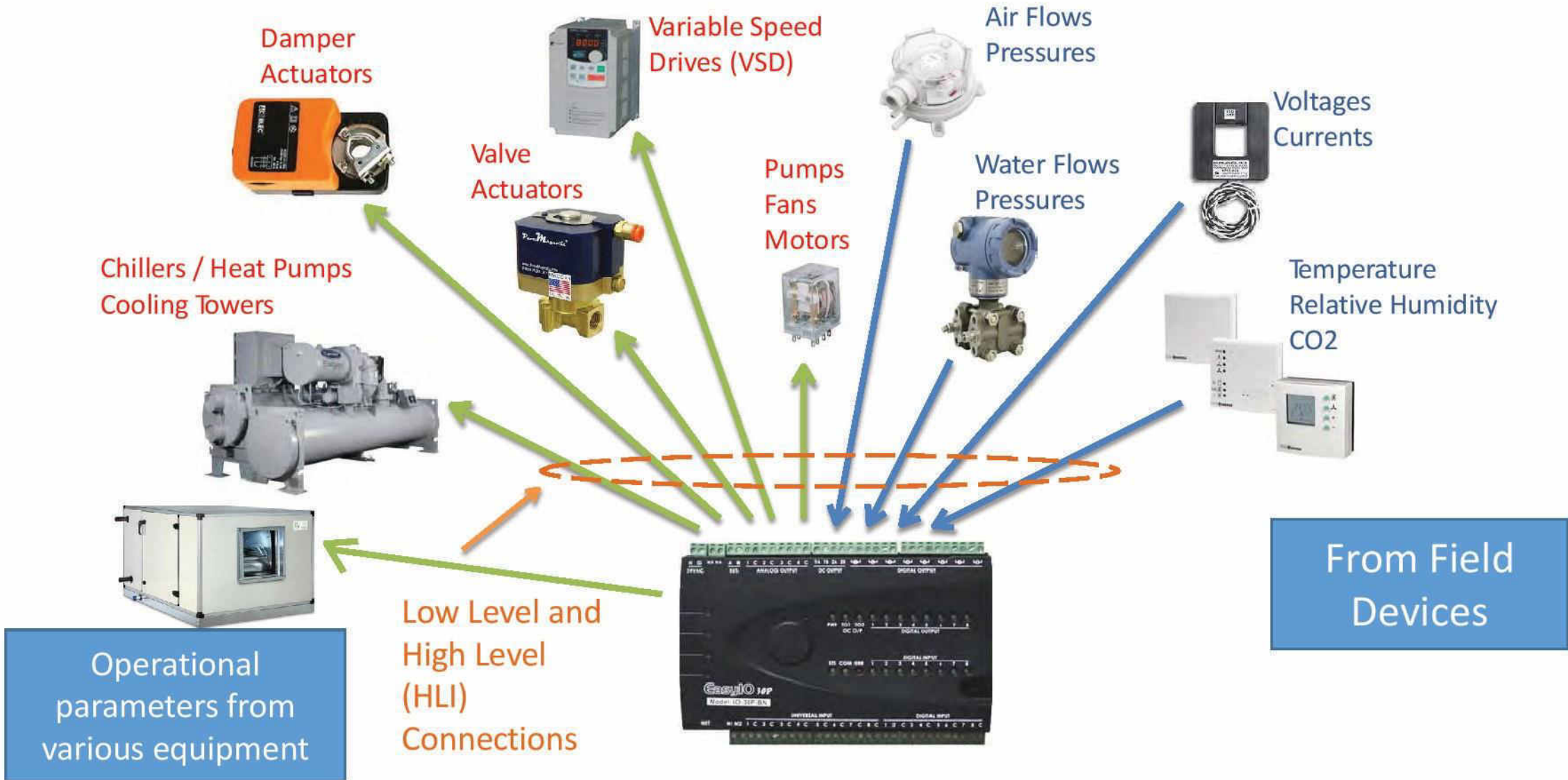

Typical System Components – BMS Hardware

Range to Suit Applications

Operator Workstations

High Point



Built In Displays



Factory programmed



Application Specific



IO Point Counts

Commands to controllers

Based on the programs and sequence of operation

Building the DDC Controllers with Input / Output Points

AI (analog input)

- Inputs to the DDC; For Monitoring purpose
- Inputs from Temperature/Pressure Sensor/ Analog Devices
- Signal:- 0-10 V or 4-20mA

DI (digital input)

- Inputs to the DDC; For Monitoring Purpose
- Inputs from Switches/ Digital devices/ Starter Panels

AO (analog output)

- For Control purpose
- Outputs to Actuating devices like Valves, VFDs etc.,
- Signal:- 0-10 Vdc or 4-20mA

DO (digital output)

- For Control Purpose
- Outputs to MCC Panels/ Isolation Valves, Fans, pumps etc to start/stop or open/close

Field Devices – Sensors & Switches

Temperature Sensor

- Immersion/Duct/ Room Type

Pressure Sensor

- Static Pressure/ Differential pressure Type

Humidity Sensor

- Duct/ Wall Type

CO₂ Sensor

- Duct/ Wall Type

BTU Meters

- Ultrasonic/ Magnetic Type

Level Sensor

- Ultrasonic / Capacitance Type

Air Flow Measurement Station

- Duct/ Pitot Type

Diff Press Switch/Tranducer

- Air / Water Type

Level Switch

- Single Level/ Bi Level Type

Cabling and Communication

Signal Cable

- For Monitoring and Controlling
- 0-10 Vdc or 4-20mA
- Usually 2C x 1 Sqmm Shielded Cable

Power Cable

- To provide power to Sensors
- Usually 3C x 1.5 Sqmm Cable

Communication Cable

- Communication between DDC and Supervisory Controllers
- Depends on System to System

BMS
Wiring

BMS Integration - Typical

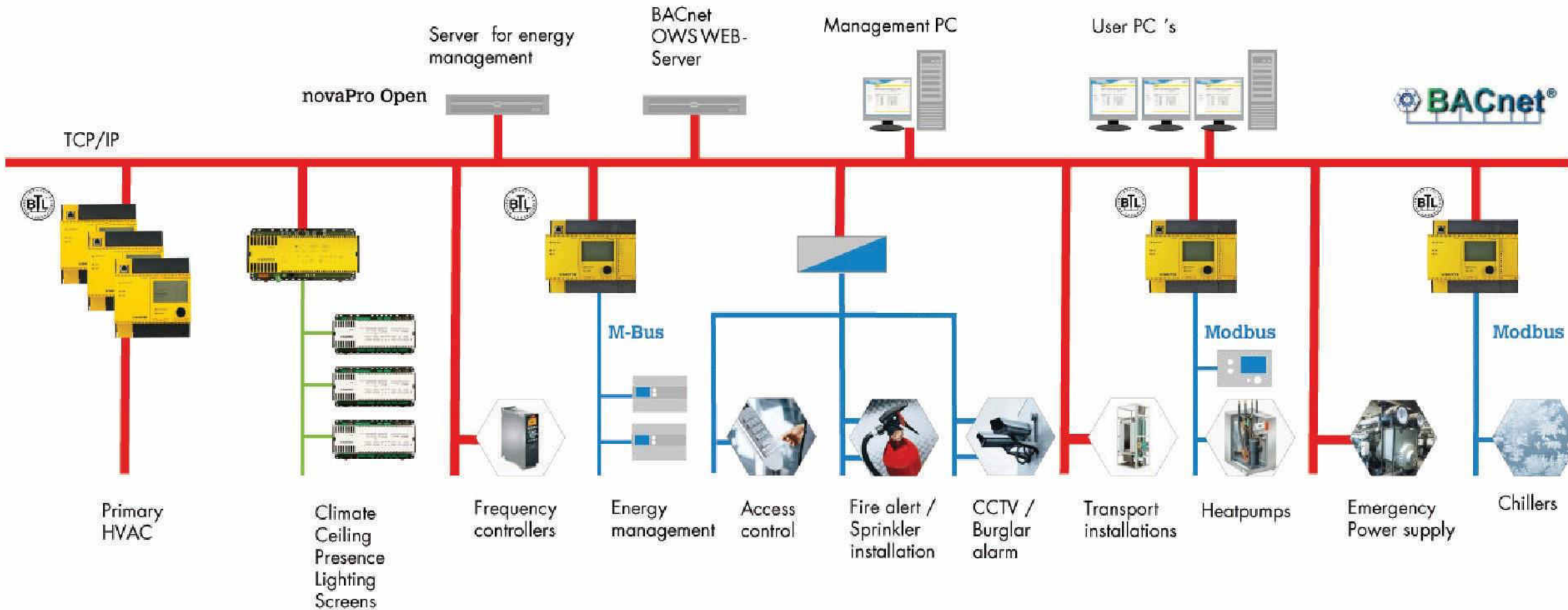

System Architecture for a generic BMS

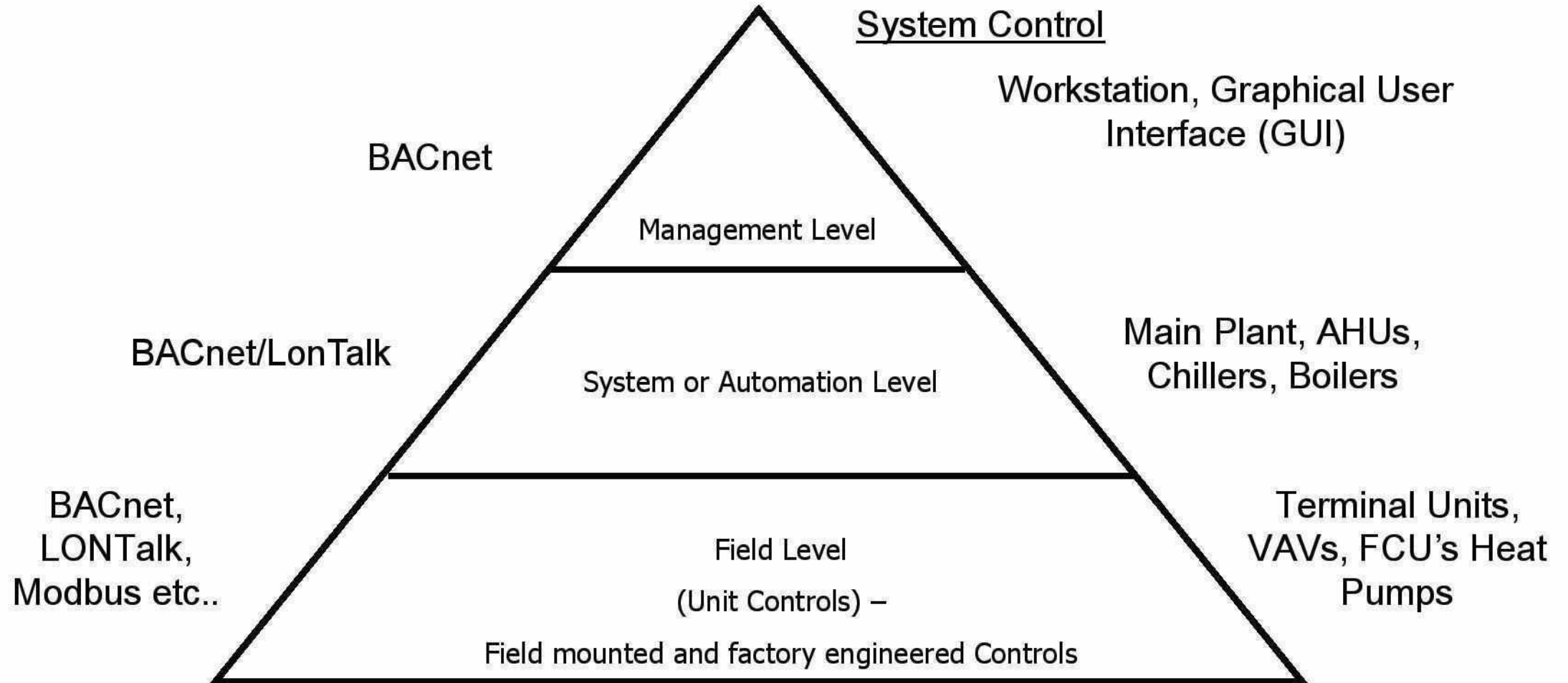

ModBus

Industrial “defacto” standard

Developed originally by Modicon

Allows data exchange

Many variations exist – Modbus RTU
(remote terminal unit) is most common

Implemented in a variety of HVAC and industrial equipment

- VFDs
- fume hood controllers
- **power monitoring equipment**
- lighting control panels
- DG Sets
- UPS
- Precision Air Conditioners



Rodent System Integration



PARAMETER	UNIT	UPS & BATT Rm	DC,Comms & PAC	TE 4F HUB RM	TE 2F&3F HUB RM	TD 2F&3F HUB RM
Wave Speed	wps	0.0	0.0	0.0	0.0	0.0
Wave Density	KHz	0.0	0.0	0.0	0.0	0.0
Current Band	—	0.0	0.0	0.0	0.0	0.0
Total Transducers	Qty	0.0	0.0	0.0	0.0	0.0
Faulty Transducers	Qty	0.0	0.0	0.0	0.0	0.0

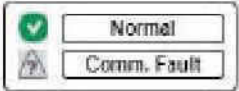

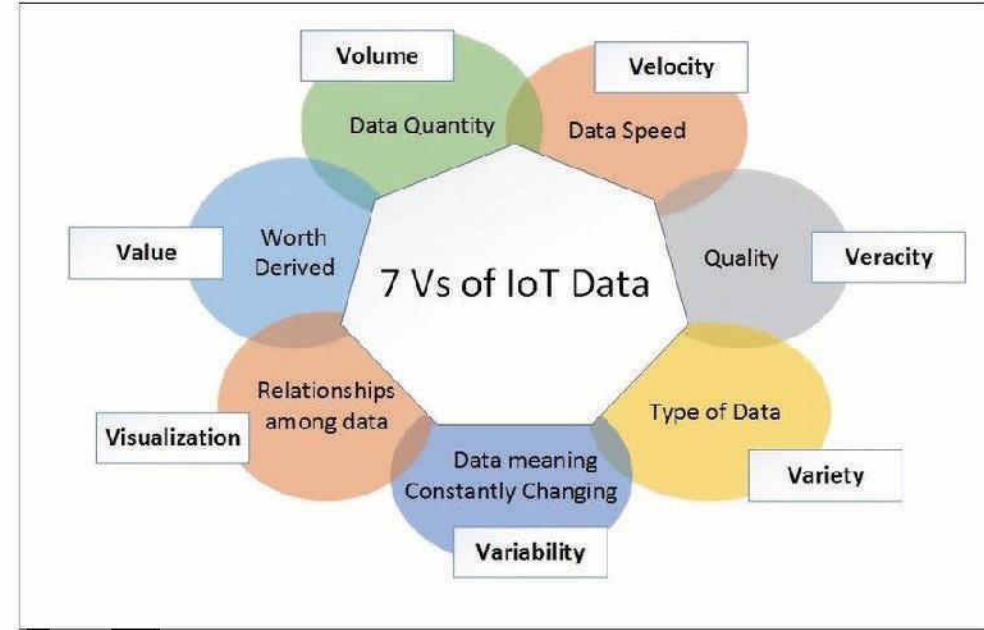
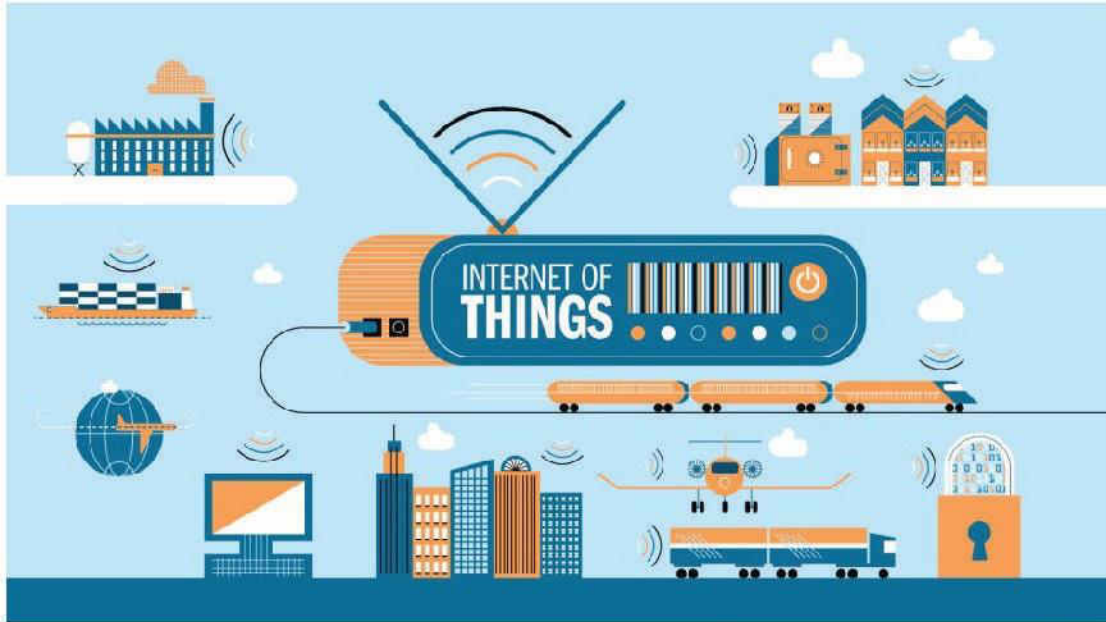

Internet of Things - IoT

The Internet of Things
From connecting devices to human value

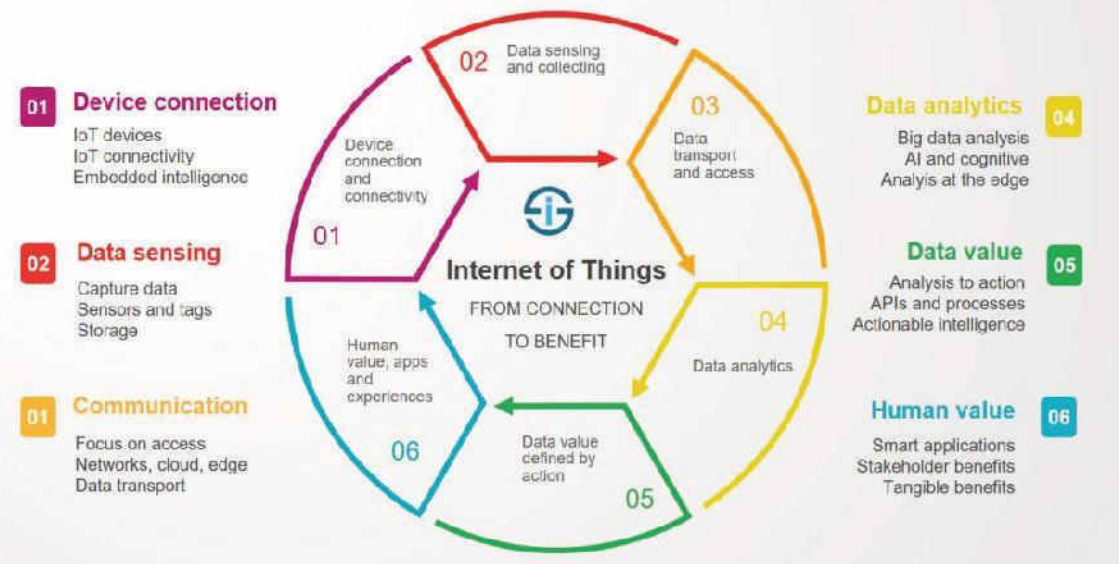

The **Internet of Things**, or **IoT**, is a system of interrelated computing devices, mechanical and digital machines, objects, animals or people that are provided with unique identifiers (UIDs) and the ability to transfer data over a network without requiring human-to-human or human-to-computer interaction.

System Architecture for IoT

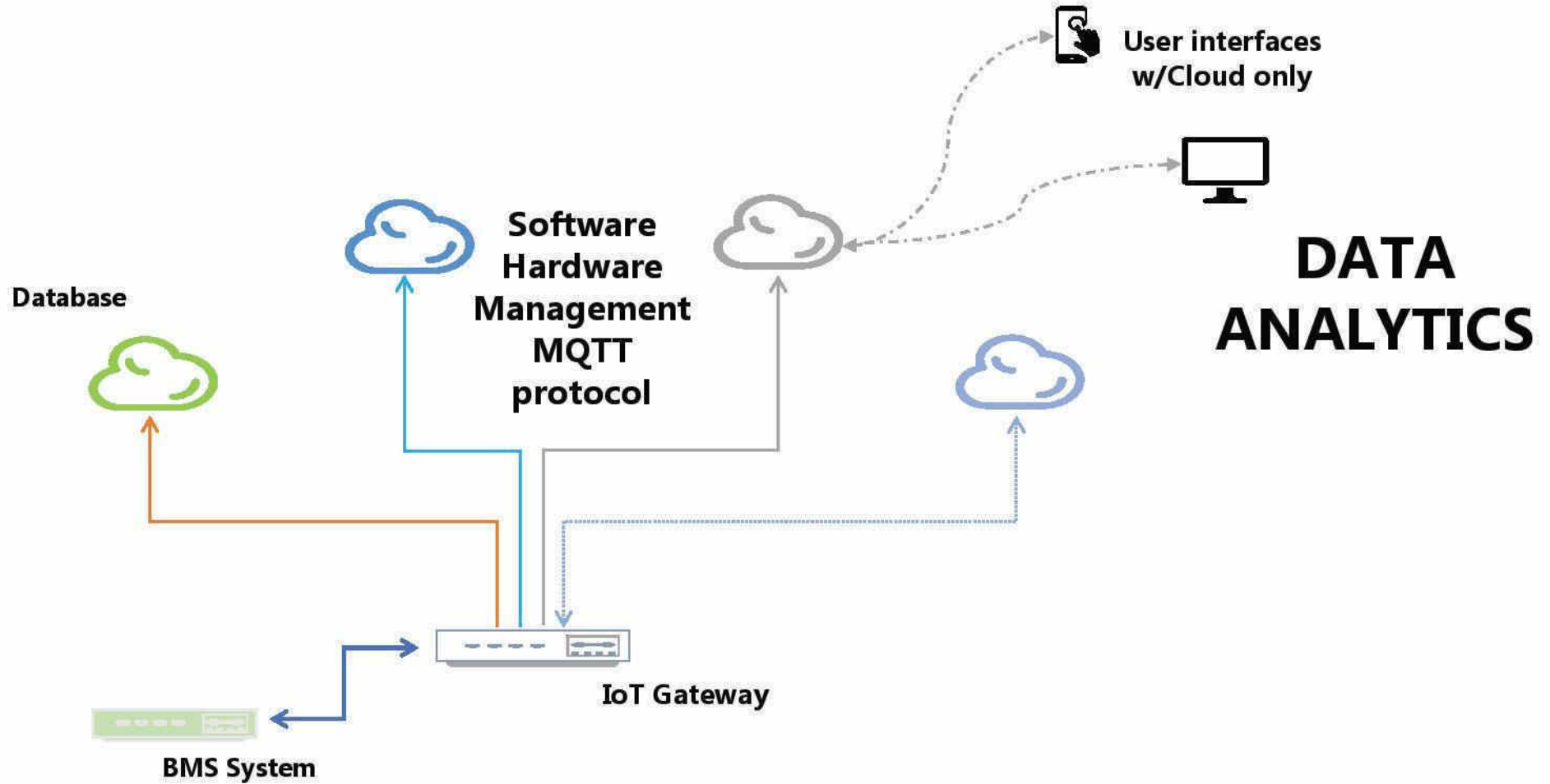

Drone is next generation SPY and Remotely Monitoring&Action

Drone Service Provider



System Configuration

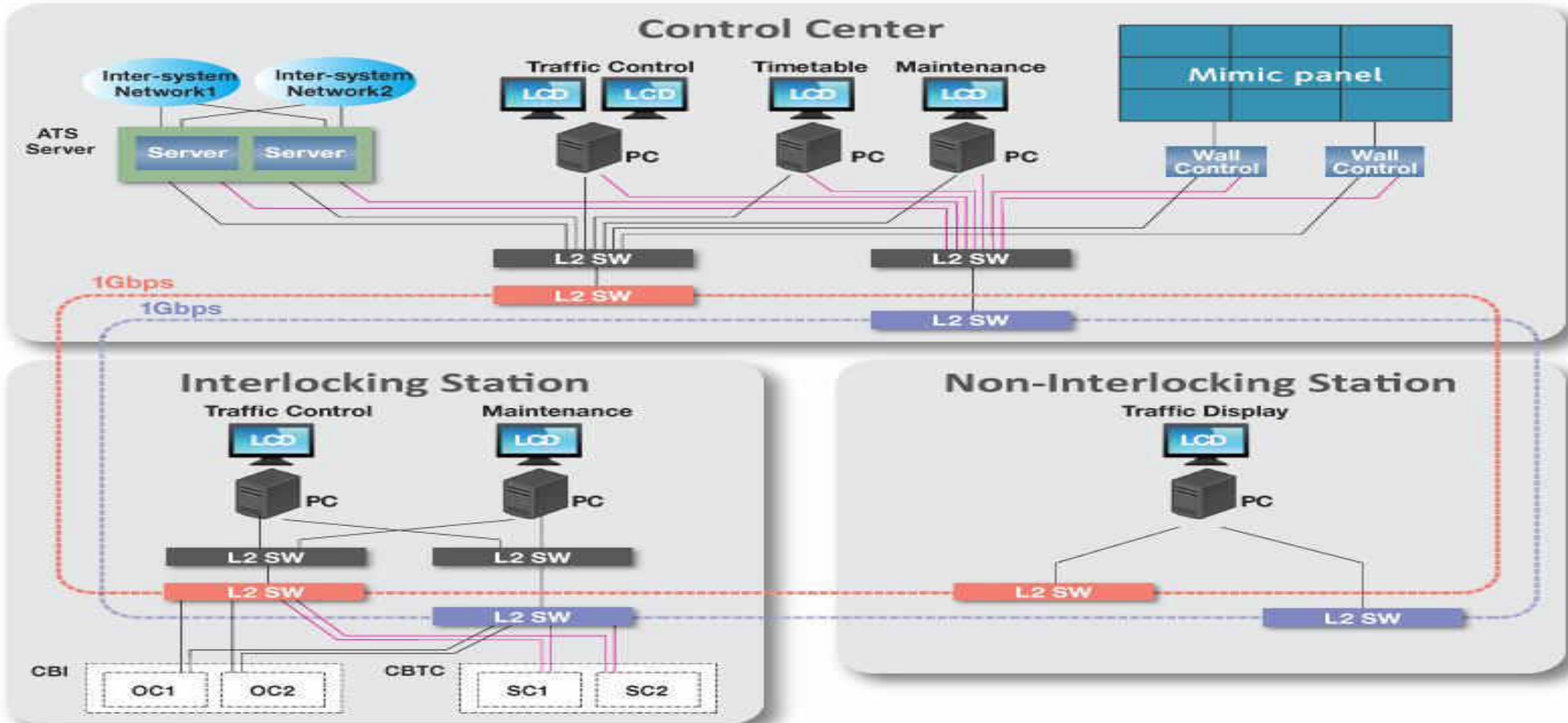

Fiber Optic Cable Network Architecture

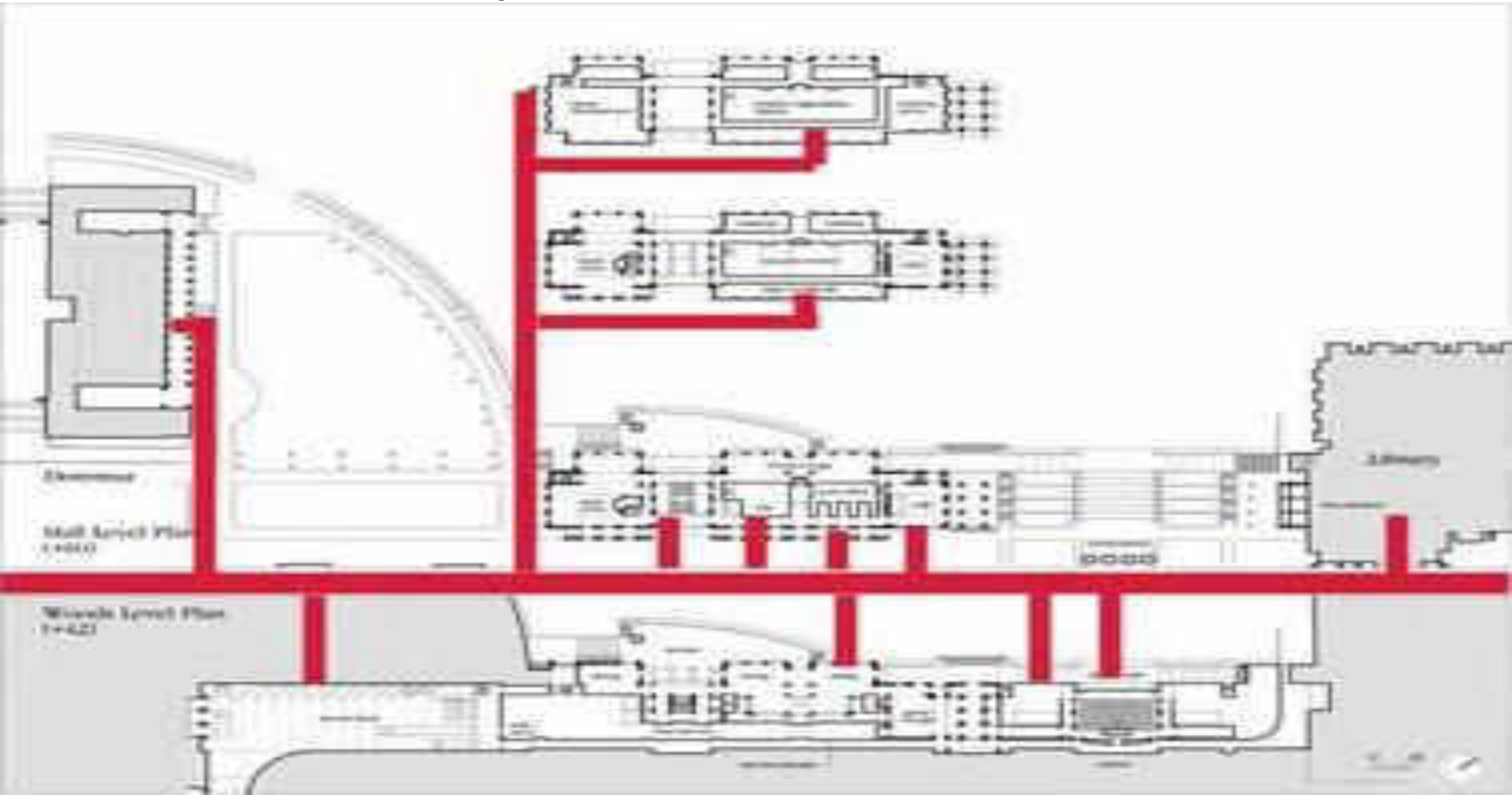

PERIMETER INTRUSION DETECTION SYSTEM

Perimeter Intrusion Detection System (PIDS) is designed to protect assets within a perimeter by detecting intruders attempting to gain access and blocking such access using the control station. Blue Star E&E offers robust and reliable solutions for accurate detection of such unauthorised entry and protection of assets against these threats. The company's turnkey solutions can detect any unauthorised physical intrusions across the perimeter, assess the situation and track intruders for future actions. Features such as instant alarm generation and control by reporting to central monitoring station make it easier to manage such situations. ¶

PIDS solutions from Linkvue Systems Pvt Ltd are based on microwave technology, Optical Fibre Cable (OFC) or video cameras. These can be fence mounted, buried underground or can be tailored for specific needs, based on customer requirements. Seamless integration of PIDS with other security systems adds one more layer of comfort for the customer. This security system is well suited for military bases, government facilities, oil refineries, petrochemical plants, power plants, sea ports, airports, VIP residences, storage yards and so on. ¶

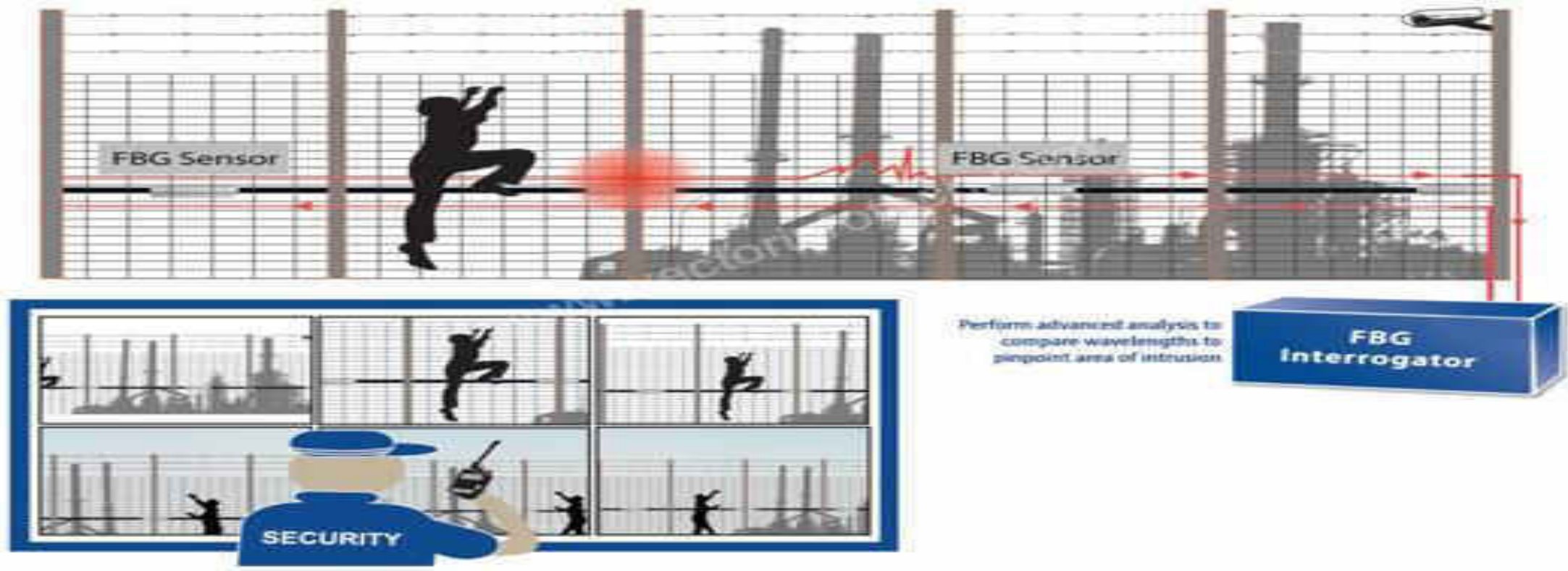

Safe Guard Your Solar Plant from Un Authorized Trespass

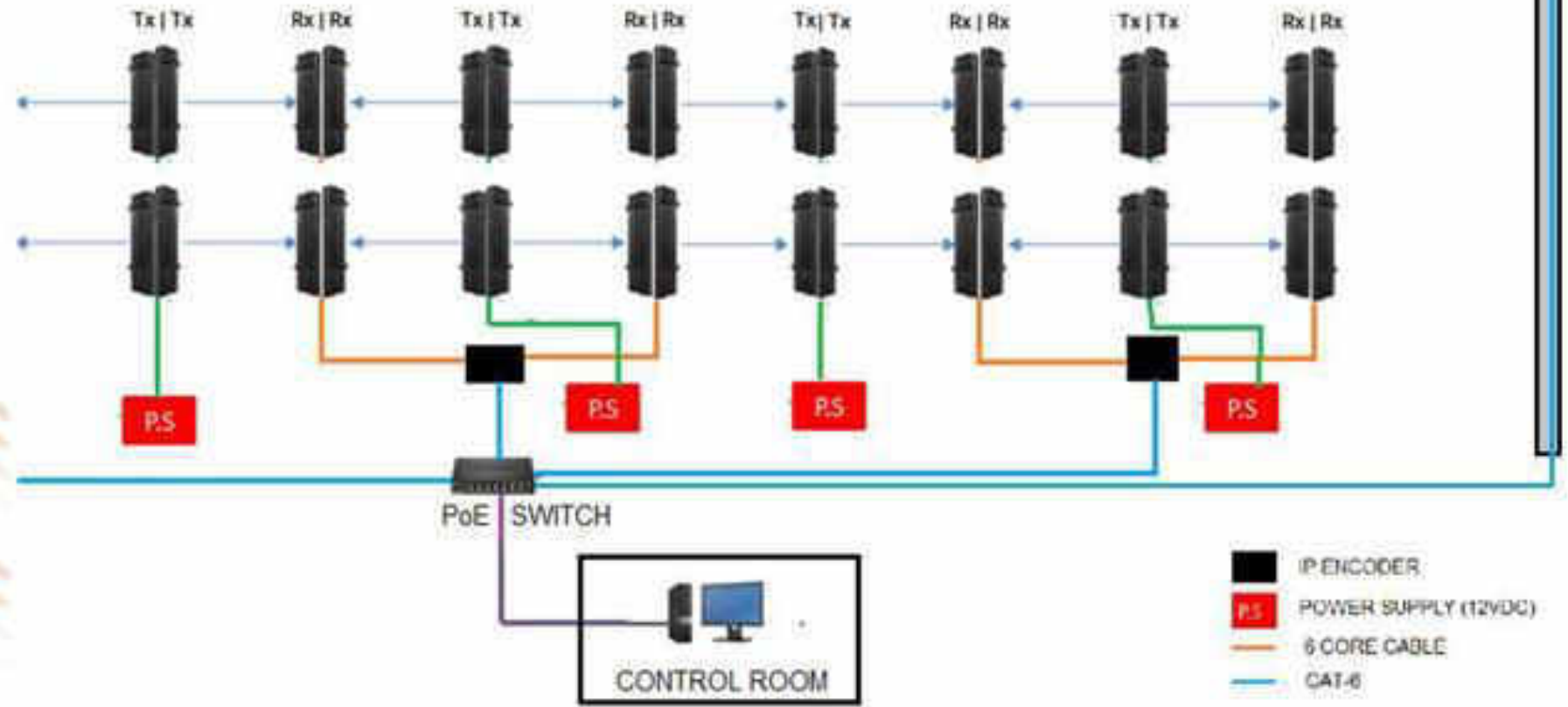
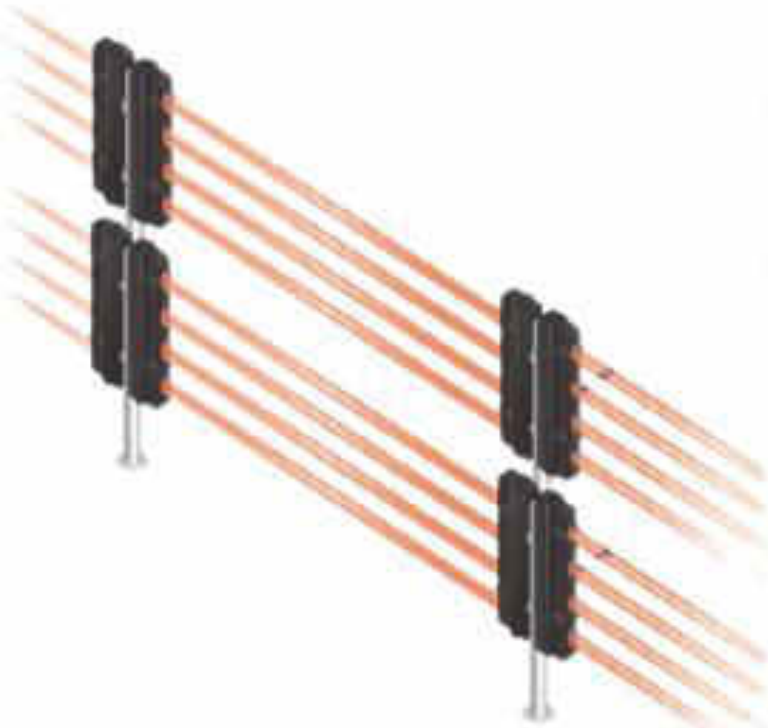
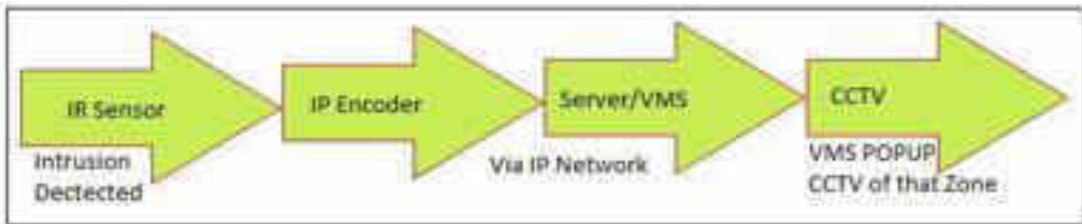

Motion Sensor with Alarm Management

- Beam detectors come in a pair of transmitter and receiver. Each transmitter sends four IR beams and is received at the receiver.
- When all four beams are blocked by an intruder, then an alarm is communicated to the control panel / sounder.
- SL series quad beam detectors have dry contacts available for connection to all kind of alarm panels.
- Easy to install system, comes with automatic beam alignment unit. Removes human error element with 5 Year Warranty.
- Effective and efficient in securing medium threat locations like office buildings, warehouses, solar farms etc.



Maximum Detection range: 200m / 650ft

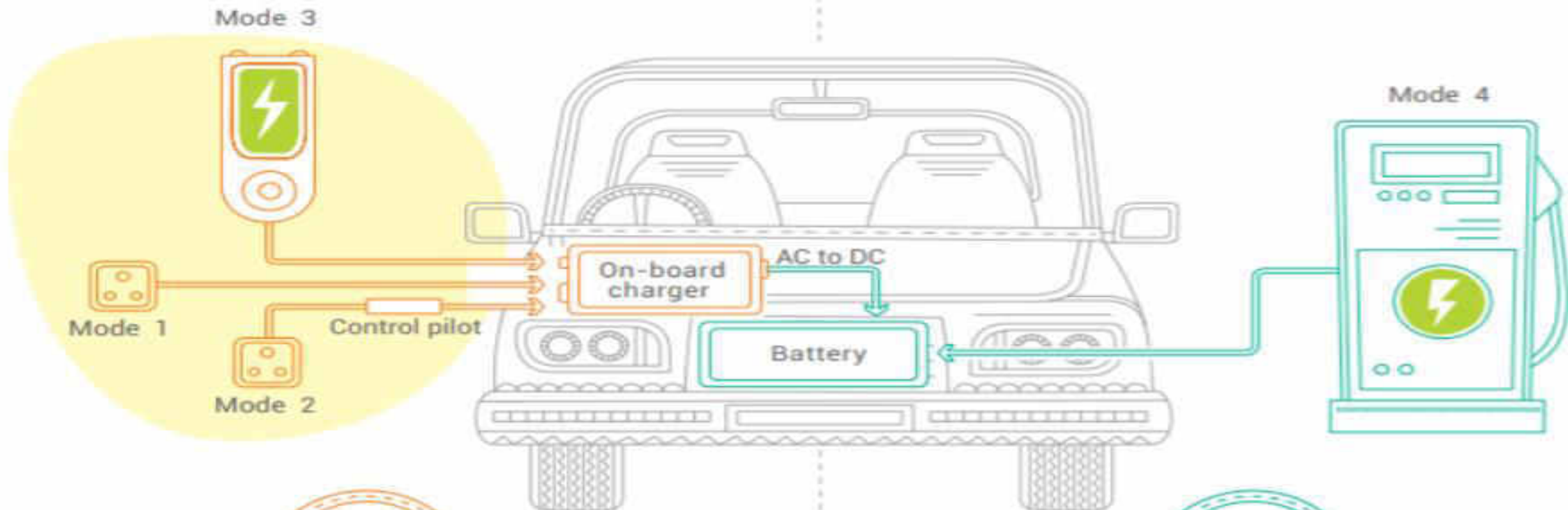

AC
(2kW TO 22kW)

DC
(2kW TO 200kW +) DC



3 PIN



Type 1



Type 2



CHAdemo







Combo 2



Type 2

Electrical Vehicle Connectors for ON Board & Charging Unit

Standard	CHAdeMO IEEE 2030.1.1 IEC 62196-3 (Configuration AA)	GB/T GB/T 20234.3 IEC 2196-3 (Configuration BB)	CCS Type 1 SAE J1772 IEC 62196-3 (Configuration EE)	CCS Type 2 IEC 62196-3 (Configuration FF)	Tesla
Coupler Inlet					
Maximum Voltage	1000 V	1000 V	600 V	1000 V	410 V
Maximum Current	400 A	250 A	200 A	200 A	330 A
Available Power	400 kW	120 kW	150 kW	175 kW	135 kW

Electric Vehicle AC & DC Charging Unit for All Vehicles 3KW-360KW



3.5KW / 7KW Portable AC Charging Box

Product Name	3.5KW / 7KW Portable AC Charging Box
Rated current	16A/32A
Power	3.5KW / 7KW
Operation voltage	250V
Insulation resistance	> 500MQ(DC500V)
Contact Resistance	0.5mΩ Max
Terminal temperature rise	< 50K
Withstand voltage	1500V
Mechanical life	no-load plug in/out > 10000 times
Coupled insertion force	45N < F < 100N
Impact of external force	can afford 1M drop
Operating temperature	-30°C~+50°C
Case material	thermoplastic, flame retardant grade UL94 V-0
Terminal	Copper alloy, silver plating
Leakage protection	Overvoltage, undervoltage, protection/Over load protection/Lightning protection

7KW Easy-use Charging Box

Product Name	7KW Easy-use Charging Box
Type	KY-AC-7KW
Dimension(mm)	180*130*120mm
AC Power	220Vac±20% ; 50Hz±10% ; L+N+PE
Rated Current	32A
Output Power	7kW
Working Condition	Elevation : ≤2000m; Temperature : -20°C~+50°C ;
Charging Mode	Plug and Charge
Protection Function	Overvoltage, undervoltage, overcurrent, short circuit, surge, leakage, etc.
Executive Standard	IEC 62196, SAE J1772
Cable Length	5m (optional)
Protection Level	Ip54

Electrical properties

1. Rated working current : 10A/16A/32A/63A
2. Working voltage: 250/440V, preferred value 750V
3. Insulation resistance : >1000MQ(DC500V)
4. Terminal temperature rise : <50K
5. Seal: rubber or silicone i Pressure : 2000V
6. Vibration resistance: meet the requirements of JDQ53.36.1.1-53.36.1.2
7. Contact impedance: 0.5MQMAX
8. Contact number: 5

Mechanical property

1. Mechanical life: no load >10000 times
2. When coupling, plug and pull force : <100N

7KW Easy-use Charging Box

Product Name	7KW Easy-use Charging Box
Type	SE-AC-7KW
Dimension(mm)	150*150*60
AC Power	220Vac±20% ; 50Hz±10% ; L+N+PE
Rated Current	32A
Output Power	7kW
Working Condition	Elevation : ≤2000m; Temperature : -20°C~+50°C ;
Charging Mode	Plug and Charge
Protection Function	Overvoltage, undervoltage, overcurrent, short circuit, surge, leakage, etc.
Executive Standard	IEC 62196, SAE J1772
Cable Length	5m (optional)
Protection Level	Ip54

Material application

1. Shell material: Thermoplastic, flame retardant grade UL94V-0
2. Pin: copper alloy, silver plated surface + thermoplastic top
3. Seal: rubber or silica gel

Work environment

1. Working environment temperature : -40°C~+105°C

Level of protection

1. Product protection level : IP55

AC 7KW Wall-mounted, Column-type AC Charging Station

Product Name	AC 7kw Charging Station
Type	SE-AC-7KW Plastic version (Commercial Using)
Dimension(mm)	450*130*305
User Interface	4.3 inch highlight display
AC Power	220Vac±20% ; 50Hz±10% ; L+N+PE
Rated Current	32A
Output Power	7kW
Working Condition	Elevation : ≤2000m; Temperature : -20°C~+50°C ;
Charging Mode	swipe card, scan code
Networking Mode	2G, 4G, wifi
Operation Mode	Offline no billing, offline billing, online billing
Protection Function	Overvoltage, undervoltage, overcurrent, short circuit, surge, leakage, etc.
Executive Standard	IEC 62196, SAE J1772
Cable Length	5m (optional)
Protection Level	Ip54
Installation	Wall-mounted or floor-mounted installation

7KW Wall-mounted Column-type AC Charging Station

Product Name	7KW AC Charging Station (Real-estate type)
Type	SE-AC-7KW (Home using, Commercial Using)
Dimension(mm)	370*255*85
User Interface	4.3 inch screen
AC Power	220Vac±20% ; 50Hz±10% ; L+N+PE
Rated Current	32A
Output Power	7kW
Working Condition	Elevation : ≤2000m; Temperature : -20°C~+50°C ;
Charging Mode	swipe card, scan code
Networking Mode	2G, 4G, wifi
Operation Mode	Offline no billing, offline billing, online billing
Protection Function	Overvoltage, undervoltage, overcurrent, short circuit, surge, leakage, etc.
Executive Standard	IEC 62196, SAE J1772
Cable Length	5m (optional)
Protection Level	Ip54
Installation	Wall-mounted or floor-mounted installation

SE-DC-30/40KW Charging Station

Product Name	Integrated DC Charging Station	
Type	SE-DC-30KW	SE-DC-40KW
Dimension(mm)	550*200*1620 (mm)	
User Interface	4.3 inch touch screen	
Input voltage	AC380V±20%	
Rated Current	67-70A	
Output Power	30KW	40KW
Working Condition	Elevation : ≤2000m; Temperature : -20°C~+50°C ;	
Charging Mode	swipe card, scan code	
Networking Mode	Ethernet, 4G, wifi	
Input frequency	45-65Hz	
Protection Function	Overvoltage, undervoltage, overcurrent, short circuit, surge, leakage, etc.	
Executive Standard	IEC 62196, SAE J1772	
Cable Length	5m (optional)	
Protection Level	Ip54	

DC Portable Charging Station

Product Name	Portable DC 3.5kw Charging Box			
Type	SE-DC-7KW	SE-DC-15KW	SE-DC-20KW	SE-DC-30KW
Dimension(mm)	345*175*265 540*375*195 540*375*195 540*375*195			
User Interface	Digital tube, LED			
Output Voltage	200V-750V	200V-750V	200V-750V	200V-750V
Power factor	≥0.99 (above 50% load)			
HMI	LED			
Working Condition	Elevation : ≤3000m; Temperature : -20°C~+50°C ;			
Charging Mode	Switch Start			
Output Frequency	45-65 Hz			
Protection Function	Overvoltage, undervoltage, overcurrent, short circuit, surge, leakage, etc.			
Executive Standard	IEC 62196, SAE J1772			
Cable Length	5m (optional)			
Protection Level	Ip54			

AC 14 KW Double plugs AC Charging Station

Product Name	AC 14kw Charging Station	
Type	SE-AC-14KW	
Dimension(mm)	480*350*120	
User Interface	4.3 inch highlight display	
AC Power	220Vac±20% ; 50Hz±10% ; L+N+PE	
Rated Current	32A	
Output Power	14kW	
Working Condition	Elevation : ≤2000m; Temperature : -20°C~+50°C ;	
Charging Mode	Swipe card, scan code	
Networking Mode	Ethernet, 4G, wifi	
Operation Mode	Offline no billing, offline billing, online billing	
Protection Function	Overvoltage, undervoltage, overcurrent, short circuit, surge, leakage, etc.	
Executive Standard	IEC 62196, SAE J1772	
Cable Length	5m (optional)	
Protection Level	Ip54	
Installation	Wall-mounted or floor-mounted installation	

SE-DC-60KW/80KW Charging Station SE-DC-120/180KW Charging Station

Product Name	Integrated DC Charging Station	
Type	SE-DC-60KW	SE-DC-80KW
Dimension(mm)	720*557*1700(mm)	
User Interface	7 inch LCD color display touch screen	
Input voltage	AC380V±20%	
Rated Current	100-180A	
Output Power	60KW	80KW
Working Condition	Elevation : ≤2000m; Temperature : -20°C~+50°C ;	
Charging Mode	swipe card, scan code	
Networking Mode	Ethernet, 4G, wifi	
Input frequency	45-65Hz	
Protection Function	Overvoltage, undervoltage, overcurrent, short circuit, surge, leakage, etc.	
Executive Standard	IEC 62196, SAE J1772	
Cable Length	5m (optional)	
Protection Level	Ip54	

SE-AC-22/44KW double Plugs Floor standing type AC Charging Station

Product Name	AC 22/44 kw Charging Station	
Type	SE-AC-22/44KW	
Dimension(mm)	500*350*130	500*350*130
User Interface	4.3 inch highlight display	
AC Power	380Vac±20% ; 50Hz±10% ; L+N+PE	
Rated Current	32A	
Output Power	22kW	44kW
Working Condition	Elevation : ≤2000m; Temperature : -20°C~+50°C ;	
Charging Mode	swipe card, scan code	
Networking Mode	Ethernet, 4G, wifi	
Operation Mode	Offline no billing, offline billing, online billing	
Protection Function	Overvoltage, undervoltage, overcurrent, short circuit, surge, leakage, etc.	
Executive Standard	IEC 62196, SAE J1772	
Cable Length	3.5m (optional)	
Protection Level	Ip54, Type B RCCB	
Installation	Wall-mounted or floor-mounted installation	

Product Name	Integrated DC Charging Station	
Type	SE-DC-120KW	SE-DC-180KW
Dimension(mm)	720*557*1700 (mm)	
User Interface	7 inch touch screen	
Input voltage	AC380V±20%	
Rated Current	250-280A	
Output Power	120KW	180KW
Working Condition	Elevation : ≤2000m; Temperature : -20°C~+50°C ;	
Charging Mode	swipe card, scan code	
Networking Mode	Ethernet, 4G, wifi	
Input frequency	45-65Hz	
Protection Function	Overvoltage, undervoltage, overcurrent, short circuit, surge, leakage, etc.	
Executive Standard	IEC 62196, SAE J1772	
Cable Length	5m (optional)	
Protection Level	Ip54	

SE-DC-240/360KW Charging Station

Product Name	Integrated DC Charging Station	
Type	SE-DC-240KW	SE-DC-360KW
Dimension(mm)	720*557*1600(mm)	
User Interface	7 inch touch screen	
Input voltage	AC380V±20%	
Rated Current	400-630A	
Output Power	240kW	360kW
Working Condition	Elevation : ≤2000m; Temperature : -20°C~+50°C ;	
Charging Mode	swipe card, scan code	
Networking Mode	Ethernet 4G, wifi	
Input frequency	45-65Hz	
Protection Function	Overvoltage, undervoltage, overcurrent, short circuit, surge, leakage, etc.	
Executive Standard	IEC 62196, SAE J1772	
Cable Length	5m (optional)	
Protection Level	Ip54	

SE-DC-120KW Charging Station

Product Name	SE-DC-120KW		
Detailed specifications Dimension(mm)	120KW		
User Interface	7 inch LCD color display touch screen		
output method	CCS/CHAdeMO	CCS/CHAdeMO	Type2
Output Power	60kw	60kw	22kw
Installation method	Floor-standing		
Route way	Down in and Down out		
Equipment size	(700 (*) 300 (*) 1672 (mm)		
Input voltage	AC380V±20%		
Input frequency	45-65Hz		
The output voltage	200-750V		
Single post output current range	0-180A		
Protection	OCP,LE		
Cable length	5m		
Measurement accuracy	0.5level		
Current limit protection value	±110%		
Regulation accuracy	±0.5%		
Steady current accuracy	±0.5%		
Ripple coefficient	≤±0.5%		
effectiveness	≥94.5%		
Power factor	≥0.99 (Above 50% load)		
Harmonic content THD	≤5% (Above 50% load)		
HMI	7 inch LCD color display touch screen, LED indicator		
Charging mode	Automatic charging / fixed power / fixed amount / fixed time		
Security Function	Data gas temperature detection, overvoltage protection, undervoltage protection, current protection, short circuit protection, grounding protection, overtemperature protection, low temperature protection, fire alarm monitoring protection, main power protection, lightning protection, emergency stop protection, plug protection		
Operating temperature	-25°C~+50°C		
Working humidity	5%~95% non-condensing		
Working altitude	≤3000m		
Protection class	IP54		
cooling method	Forced air cooling		
Noise control	≤60dB		
MTBF	≥100,000hours		

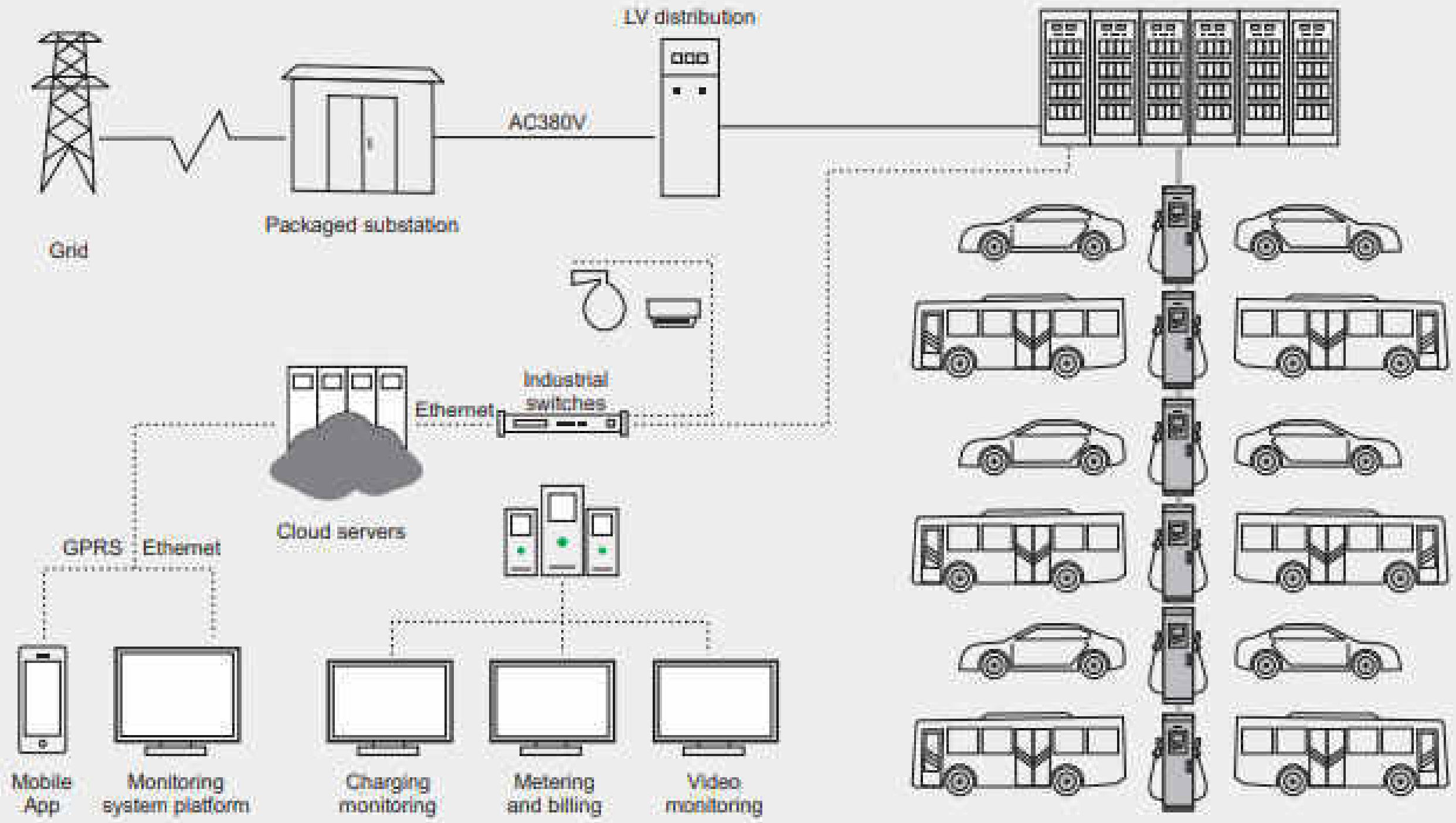

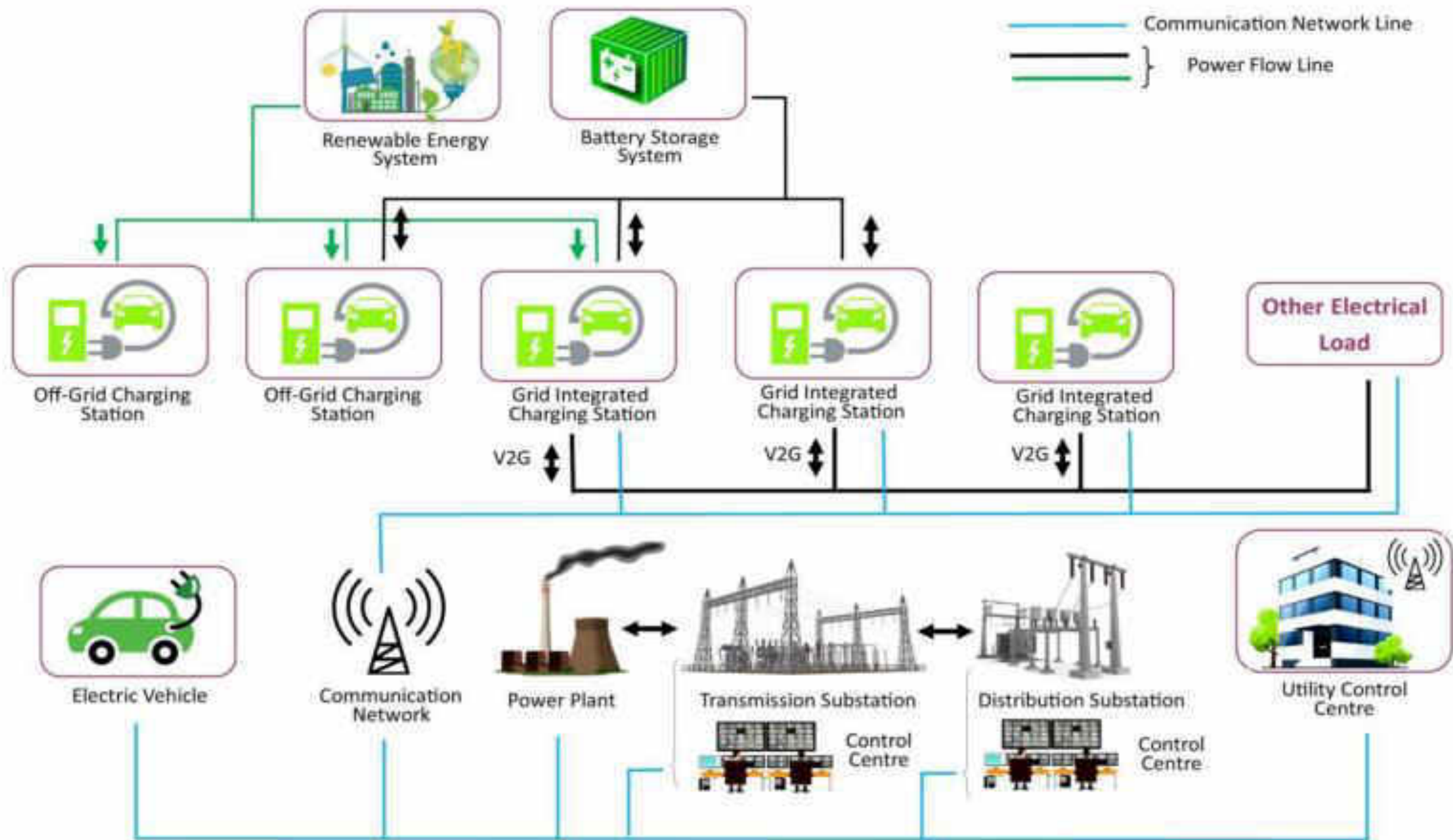

Maintenance Free Earthing installation as per IS3043(2018)

General Arrangements for Earth System

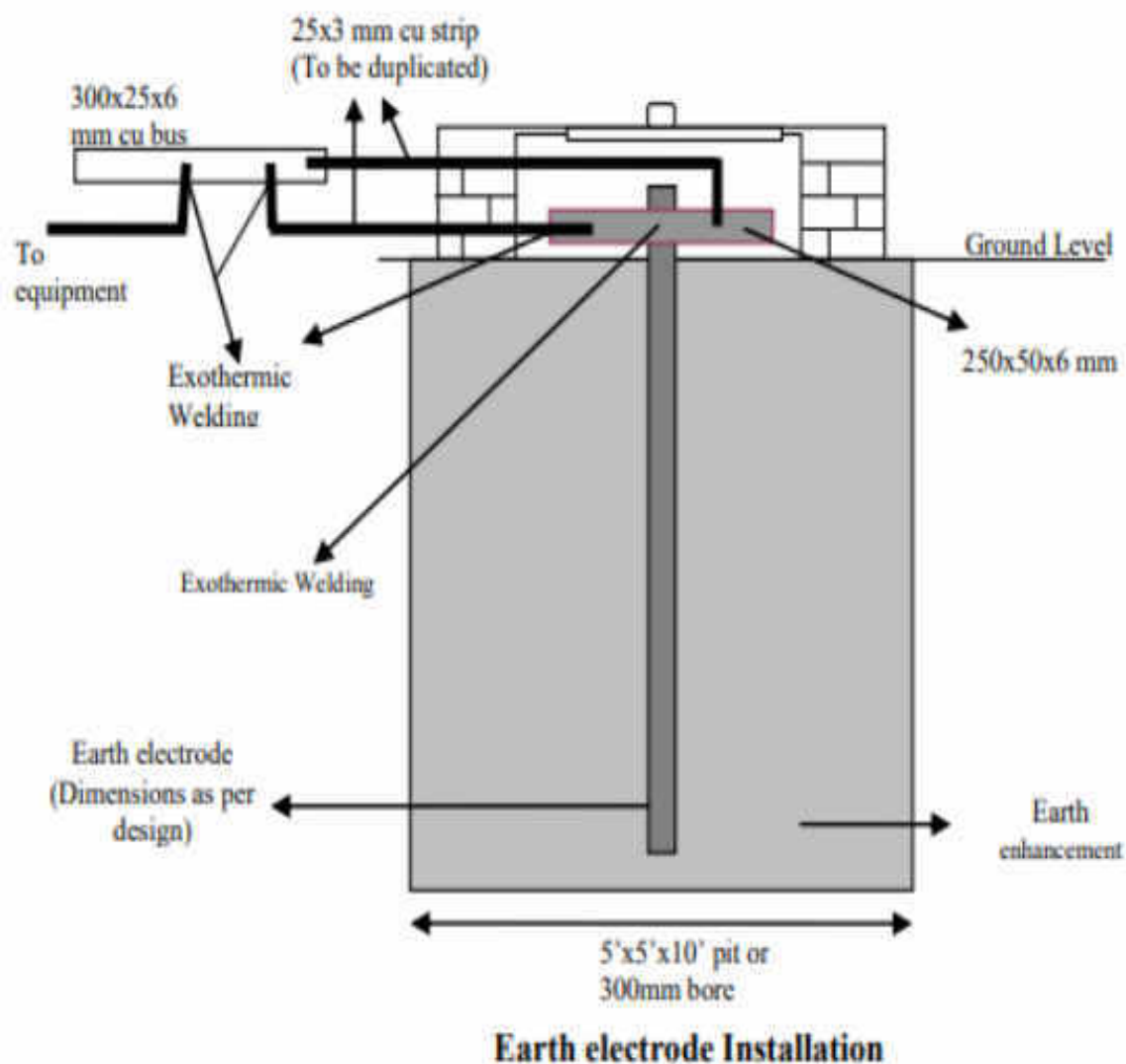

S.N.	Installations/ Current Capacity	IR Value Required	Soil Type/ Resistivity	Earth System
1.	House hold earthing/ 3kA	8 ohm	Normal Soil/ upto 50 ohm-mtr	Single Electrode
			Sandy Soil/ between 50 to 2000 ohm-mtr	Single Electrode
			Rocky Soil/ More than 2000 ohm-mtr	Multiple Electrodes
2.	Commercial premises Office buildings/ 5kA	2 ohm	Normal Soil/ upto 50 ohm-mtr	Single Electrode
			Sandy Soil/ upto 2000 ohm-mtr	Multiple Electrodes
			Rocky Soil/ More than 2000 ohm-mtr	Multiple Electrodes
3.	Transformers, substation earthing, LT line equipment/ 15kA	1 - 2 ohm	Normal Soil/ upto 50 ohm-mtr	Single Electrode
			Sandy Soil/ upto 2000 ohm-mtr	Multiple Electrodes
			Rocky Soil/ More than 2000 ohm-mtr	Multiple Electrodes
4.	Transformers, substation earthing, HT line equipment/ 40kA	less than 1 ohm	Normal Soil/ upto 50 ohm-mtr	Single Electrode
			Sandy Soil/ upto 2000 ohm-mtr	Multiple Electrodes
			Rocky Soil/ More than 2000 ohm-mtr	Multiple Electrodes
5.	Lightning arresters, extra high current applications etc./ 50kA	less than 1 ohm	Normal Soil/ upto 50 ohm-mtr	Single Electrode
			Sandy Soil/ upto 2000 ohm-mtr	Multiple Electrodes
			Rocky Soil/ More than 2000 ohm-mtr	Multiple Electrodes
6.	PRS, UTS, RTUs, FOIS, COIS, ATMs and data processing centre etc./5KA	less than 0.5 ohm	Normal Soil/ upto 50 ohm-mtr	Single Electrode
			Sandy Soil/ upto 2000 ohm-mtr	Multiple Electrodes
			Rocky Soil/ More than 2000 ohm-mtr	Multiple Electrodes

Earthing as per IS3043 and IEEE 80

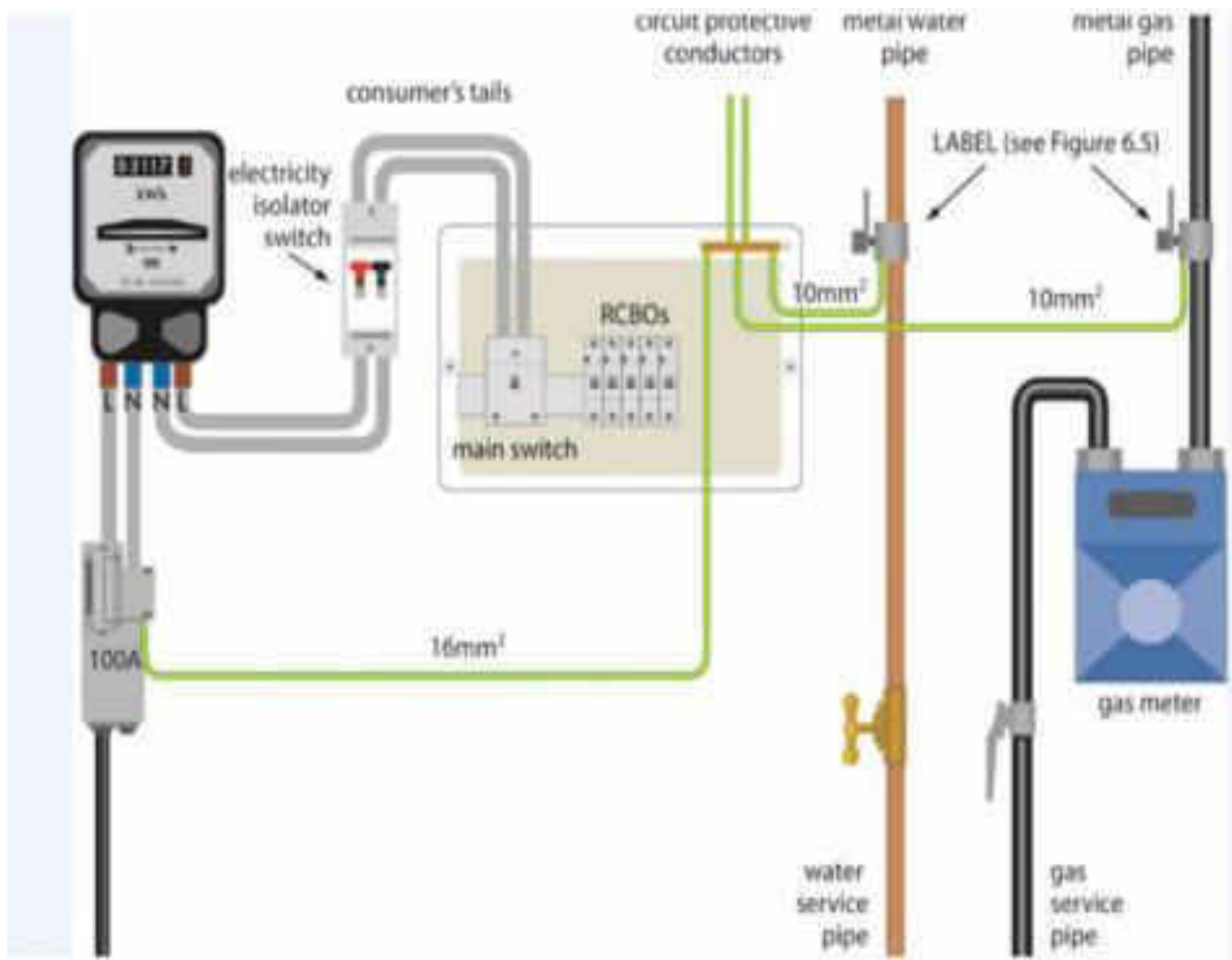
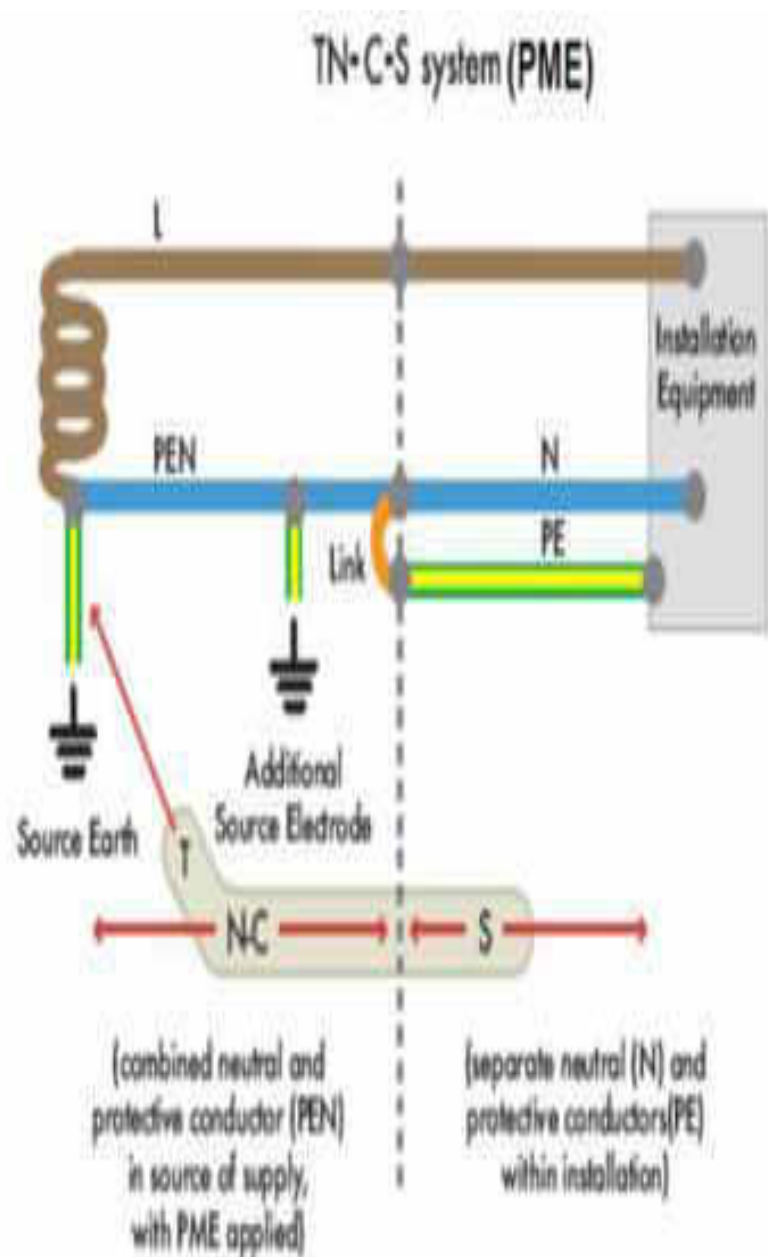

I am Power Plug I will be Marry with only My Right Partner

Make you Safety and Comfort

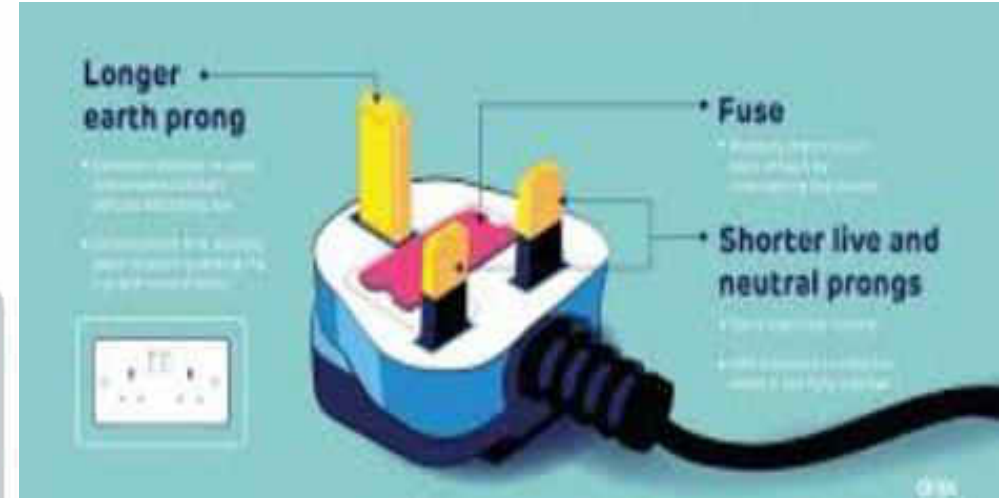
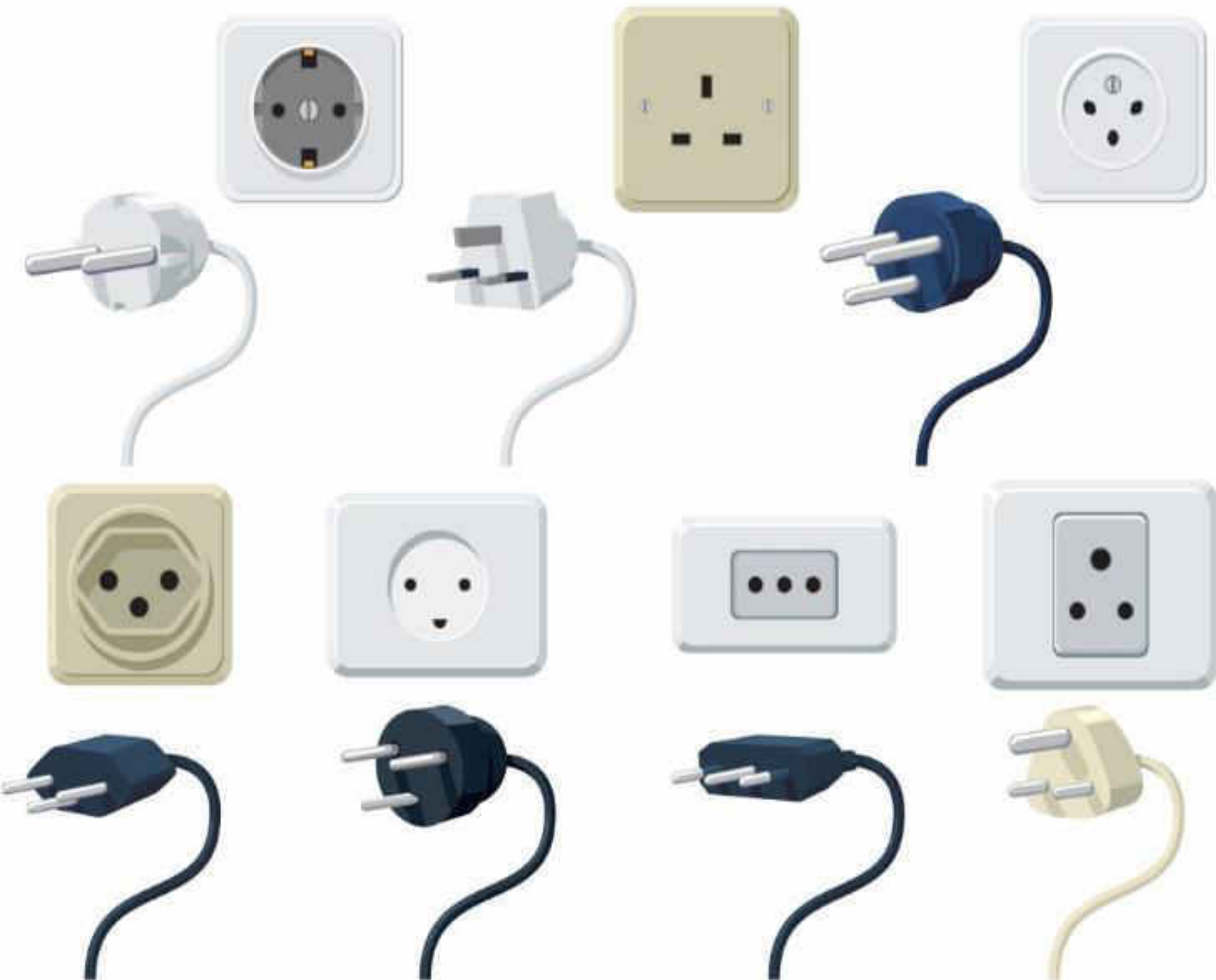

MC 4 Solar PV DC Connector Family 1800V 30Amps



Solar PV and EV Connectors / Harness



MC 4 Connectors DC Voltage 1500 V-1800V 30Amps



Electric Vehicle and Electric Vehicle Charging Connectors, Cable Harness

AC EV Charger Connector



Typ 1 (Type 1) Typ 2 (Type 2) Typ 3 (Type 3)

AC EV Charger Socket



Typ 1 (Type 1) Typ 2 (Type 2) Typ 3 (Type 3)

DC EV Charger Connector



CC (Type 1) CC (Type 2) CC (Type 3)

DC EV Charger Socket



CC (Type 1) CC (Type 2) CC (Type 3)



(EV-Standard Standard (Type 1) / Type 2) EV Charging Cable



(EV-Standard Standard (Type 1) / Type 2) EV Charging Cable



(EVFM - European Standard (Type 1) / Type 2 for Type 2 EV Charging Cable)



(EVC - American Standard to European Standard EV Plug / Type 1 to Type 2 EV Charging Cable)

Out Door IP 68 CEE Compliance Plug & Socket for Special Electrical Equipment's

2.7 CEE Plug, Socket & Coupler

2.7.1 Panel Mounted CEE Socket



3 pole



4 pole



5 pole

Ampere		3 pole	4 pole	5 pole
16A	IP44	SF1331	SF1431	SF1531
	IP67	SF1332	SF1432	SF1532
32A	IP44	SF3331	SF3431	SF3531
	IP67	SF3332	SF3432	SF3532
63A	IP44	SF6331	SF6431	SF6531
	IP67	SF6332	SF6432	SF6532
125A	IP67	SF5332	SF5432	SF5532

2.7.2 Panel side-mounted CEE Socket



3 pole



4 pole



5 pole

Ampere		3 pole	4 pole	5 pole
16A	IP44	SF1341	SF1441	SF1541
	IP67	SF1342	SF1442	SF1542
32A	IP44	SF3341	SF3441	SF3541
	IP67	SF3342	SF3442	SF3542
63A	IP44	SF6341	SF6441	SF6541
	IP67	SF6342	SF6442	SF6542
125A	IP67	SF5342	SF5442	SF5542

2.7.3 Wall mounted CEE Socket



3 pole



4 pole



5 pole

Ampere		3 pole	4 pole	5 pole
16A	IP44	SF1311	SF1411	SF1511
	IP67	SF1312	SF1412	SF1512
32A	IP44	SF3311	SF3411	SF3511
	IP67	SF3312	SF3412	SF3512
63A	IP44	SF6311	SF6411	SF6511
	IP67	SF6312	SF6412	SF6512
125A	IP67	SF5312	SF5412	SF5512

2.7.4 CEE Interlock Switch Socket



3 pole



4 pole



5 pole

Ampere		3 pole	4 pole	5 pole
16A	IP67	SF1372	SF1472	SF1572
32A	IP67	SF3372	SF3472	SF3572
63A	IP67	SF6372	SF6472	SF6572

Out Door IP 68 CEE Compliance Plug & Socket for Special Electrical Equipment's

Cable 2 Cable Plug & Sockets

2.7.5 CEE Coupler



3 pole



4 pole



5 pole

Ampere		3 pole	4 pole	5 pole
16A	IP44	SF1321	SF1421	SF1521
	IP67	SF1322	SF1422	SF1522
32A	IP44	SF3321	SF3421	SF3521
	IP67	SF3322	SF3422	SF3522
63A	IP44	SF6321	SF6421	SF6521
	IP67	SF6322	SF6422	SF6522
125A	IP67	SF5322	SF5422	SF5522

2.7.6 CEE plug



3 pole



4 pole



5 pole

Ampere		3 pole	4 pole	5 pole
16A	IP44	SF1301	SF1401	SF1501
	IP67	SF1302	SF1402	SF1502
32A	IP44	SF3301	SF3401	SF3501
	IP67	SF3302	SF3402	SF3502
63A	IP44	SF6301	SF6401	SF6501
	IP67	SF6302	SF6402	SF6502
125A	IP67	SF5302	SF5402	SF5502

2.7.7 CEE Concealed plug



3 pole



4 pole



5 pole

Ampere		3 pole	4 pole	5 pole
16A	IP44	SF1351	SF1451	SF1551
	IP67	SF1352	SF1452	SF1552
32A	IP44	SF3351	SF3451	SF3551
	IP67	SF3352	SF3452	SF3552
63A	IP44	SF6351	SF6451	SF6551
	IP67	SF6352	SF6452	SF6552
125A	IP67	SF5352	SF5452	SF5552

2.7.8 CEE Wall mounted plug



3 pole



4 pole



5 pole

Ampere		3 pole	4 pole	5 pole
16A	IP44	SF1361	SF1461	SF1561
	IP67	SF1362	SF1462	SF1562
32A	IP44	SF3361	SF3461	SF3561
	IP67	SF3362	SF3462	SF3562
63A	IP44	SF6361	SF6461	SF6561
	IP67	SF6362	SF6462	SF6562

Electric Vehicle and Out Door Safety Connectivity

1.3.2 CEE Distribution Box



SF-NP262815-1
Size:280*270*155



SF-NP262815-2
Size:280*270*155



SF-NP335317
Size:530*320*175



SF-1801
Size:240*120*120



SF-1801
Size:240*120*120



SF-NP334317-1
Size:430*320*175



SF-NP334317-2
Size:430*320*175



SF-1803
Size:215*200*200



SF-1804
Size:260*245*260



SF-1806B
Size:308*277*238



SF-NP334318-1
Size: 800*600*220



SF-NP334318-2
Size:800*600*220



SF-1807-A



SF-1807-D

1.3.3 Portable Socket Distribution



SF-1805
Size:490*140*95



SF-1805C
Size:430*120*70



SF-1086A



SF-1086-E

I am Customize and I am Answer For All Our Door Electrical



SF-1808
Size:478*340*330



SF-1808
Size:478*340*330



SF-NP1901
Size:480*480*480



SF-NP1902
Size:588*480*480



SF-NP1903
Size:460*430*380



SF-NP1904
Size:530*460*380



SF-NP1905
Size:680*630*430



SF-NP1906
Size:900*630*430

1.3.4 Electric Vehicle Distribution



SF-202001
Size:290*210*120

1.4 waterproof switch socket

1.4.1 IP66 Waterproof Box for 45*45mm modules

1) A Version



SF66-5R
Size:100*100*73
one Eu socket
waterproof box



SF66-5RS
Size:100*200*73
one Eu socket with
switch waterproof box



SF66-2SR
Size:200*100*73
2*Eu socket
waterproof box



SF66-2SR
Size:300*100*73
2*Eu socket with
switch waterproof box



SF66-3SR
Size:400*100*73
3*Eu socket
with switch
waterproof box



SF66-U
Size:100*100*73
one Universal socket
waterproof box



SF66-US
Size:100*200*73
one Universal
socket with switch
waterproof box



SF66-2U
Size:200*100*73
2*Universal socket
waterproof box



SF66-2U
Size:300*100*73
2*Universal
socket with switch
waterproof box



SF66-3U
Size:400*100*73
3*Universal
socket with switch
waterproof box



SF66-S
Size:100*100*73
one UK socket
waterproof box



SF66-SS
Size:100*200*73
one UK socket with
switch waterproof box



SF66-2S
Size:200*100*73
2*UK socket
waterproof box



SF66-2S
Size:300*100*73
2*UK socket with
switch waterproof box



SF66-3S
Size:400*100*73
3*UK socket
with switch
waterproof box



SF66-FR
Size:100*100*73
one French socket
waterproof box



SF66-FRS
Size:100*200*73
one French socket
with switch waterproof



SF66-2FR
Size:200*100*73
2*French socket
waterproof box



SF66-2FR
Size:300*100*73
2*French socket
with switch
waterproof box



SF66-3FR
Size:400*100*73
3*French socket
with switch
waterproof box

IP 68 Out door Plug&Sockets/Building Internal Electrical Cable Freedom

1.4.1 IP66 Waterproof Box for 45*45mm modules

2) B Verison



1.4.2 IP55 Waterproof Box

S/N	Picture	Item & Feature	S/N	Picture	Item & Feature
1		SF-QB-200 IP55 1 way 45*45mm modules switch control IP55 waterproof box, dimension of 85*70mm;	2		SF-QB-201 IP55 3 way 45*45mm modules one switch and one socket outlet IP55 waterproof box, dimension of 85*95mm;
3		SF-QB-202 IP55 4 way 45*45mm modules of 2* socket outlet IP55 waterproof box, dimension of 85*120mm;	4		SF-QB-41 3 ways VIMAR modules flush-mounting IP55 waterproof box
5		SF-QB-42 4 ways VIMAR modules flush-mounting IP55 waterproof box			

1.4.3 BS standard one gang/two gang waterproof box

S/N	Picture	Item & Feature	S/N	Picture	Item & Feature
1		913SPF 1 Gang 13A waterproof switch socket	2		923SPF 2 Gang 13A waterproof switch socket
3		901ALF 1 gang switch waterproof box	4		902ALF 2 gang switch waterproof box
5		WP14 BS EN 60669-1 single pole 20A, 250V			

2.4 Wiring Connectors

2.4.1 Quick Wire Connectors



FC-222-412
2 digits plug-in



FC222-413
3 digits, plug-in



FC222-414
4 digits, plug-in



FC222-415
5 digits, plug-in



FC-222-418
8 digits plug-in



FC-221
1 Line plug-in



FC-212
2 Lines plug-in



FC-313
3 Lines plug-in



FC121
1 bit, plug-in



FC-223-2P
2 Lines plug-in



FC-223-3P
3 lines, plug-in



FC-223-4P
4 Lines plug-in



FC-223-5P
5 Lines plug-in



FC-223-6P
6 Lines plug-in



FC-223-8P
8 Lines plug-in



FC-223-10P
10 Lines plug-in



FC-223-12P
12 lines, plug-in



FC-424
2 into and 4 out plug-in

Special Connectors for Low Voltage Electrical Cable FreeDOM



FC426
2 into 6 out, plug-in



FC436
3 into 6 out, plug-in



FC439
3 into 9 out, plug-in



FC-224-101
plug-in



FC773-102
2 Lines Direct insertion



FC-773-104
4 Lines Direct Insert



FC773-106
6 Lines Direct insert



FC773-108
8 Lines Direct insert



FC-773-173
3 Lines Direct insert



FC-773-174
4 digits insert directly



FC-773-252
2 lines pluggable



FC773-253
3 Lines, pluggable



FC773-254
4 Lines, pluggable



FC773-255
5 Lines, pluggable



FC773-202
2 digits, insert directly



FC-773-203
3 digits insert directly



FC-773-204
4 digits, insert directly



FC-773-205
5 digits insert directly



FC773-206
6 digits, insert directly



FC-773-208
8 digits insert directly



FC-221-412
2 Lines plug-in



FC-221-413
3 Lines plug-in



FC-221-414
4 Lines plug-in



FC-221-415
5 Lines plug-in

IP68 Waterproof connector

2.4.2 IP68 connector & block



SF-XY22-W01
No.:3P; OD:6.5mm,OD9mm,OD11mm

Wire to Wire: No.2P & 3P; OD<=7 & OD<=8; Wire dia:0.5-1.5mm²



SF-XY12-W01

Wire to wire; wire dia:0.5-1.5mm; current:16/24A



SF-XY16-W01
OD<=9 & OD<=11



SF-XYT21-W01
OD<=9 & OD<=11

Lightning Charges Travel in KM & Enter (Systems) from many medium

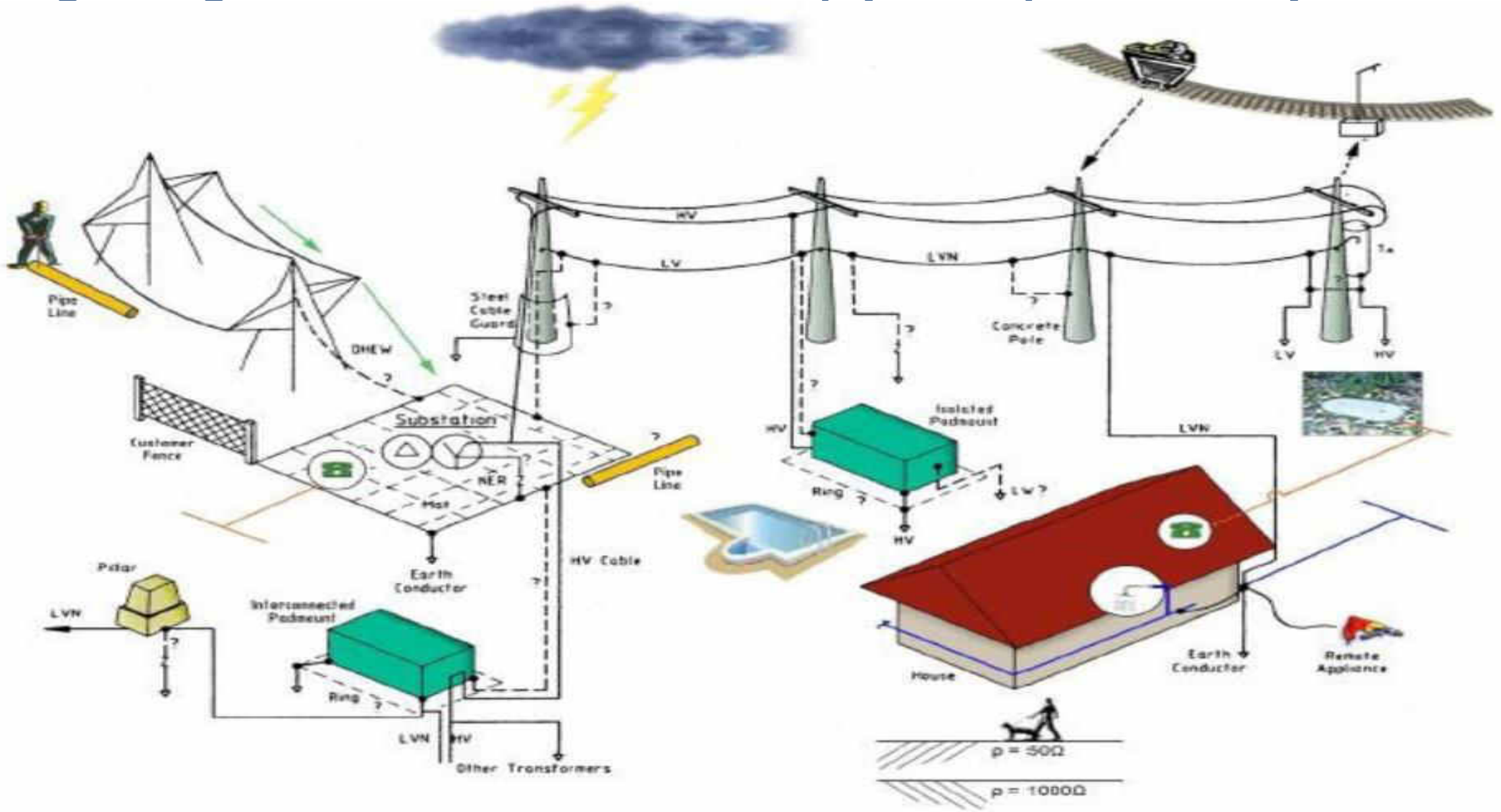

POSSIBLE SOURCES OF SURGES

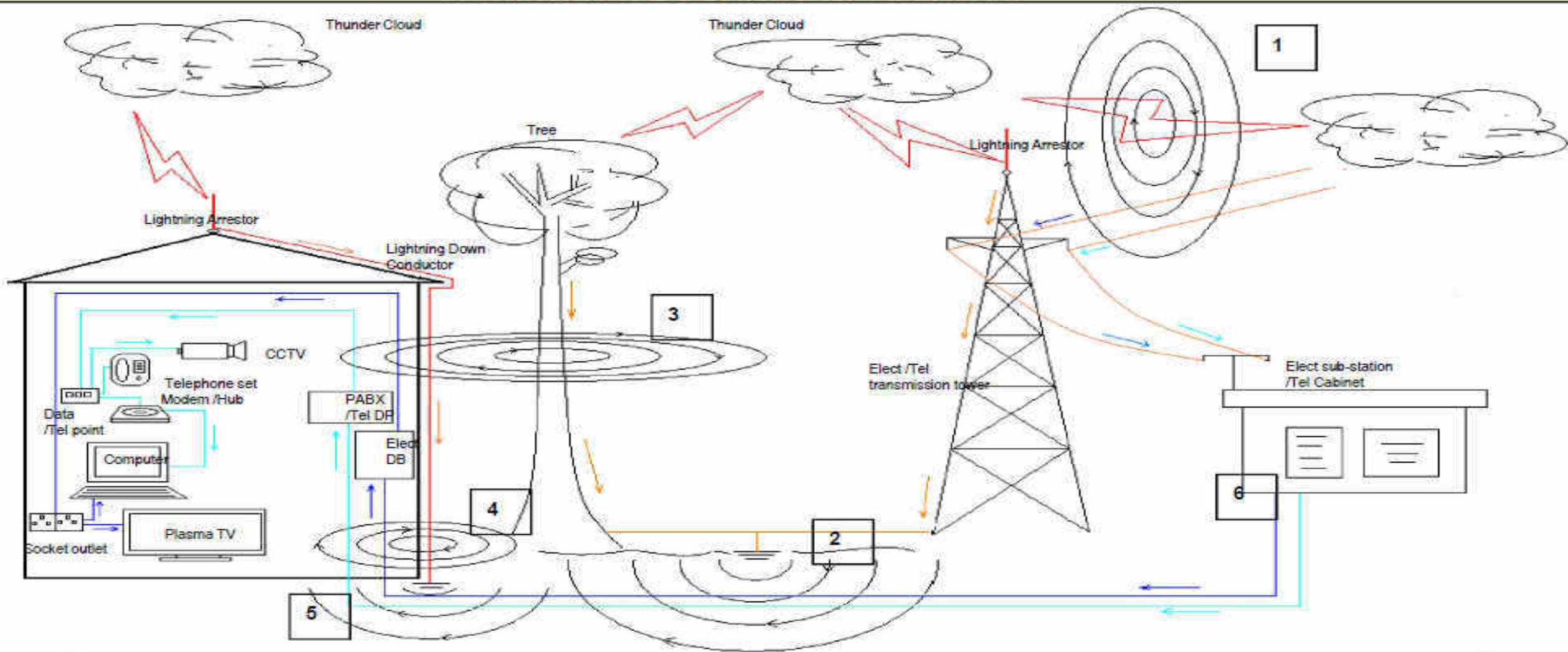

Lightning Strike



Lightning Current

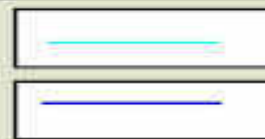

Telephone/Data Line



Power Line



Surge Current in Telephone/Data Line

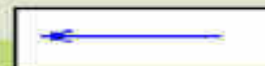

Surge Current In Power Line

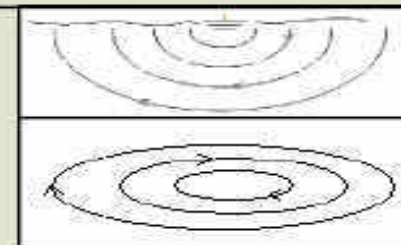

Ground Potential

Inductive Coupling

LIGHTNING PROTECTION SYSTEMS IN PHOTOVOLTAIC POWER PLANTS

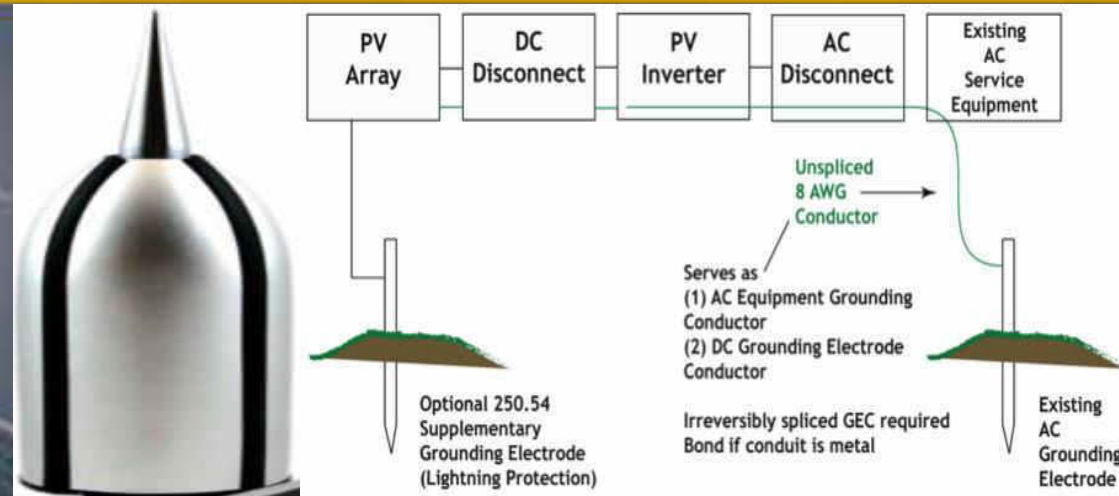

LOCAL STORM
DETECTION



AIR TERMINALS
AND ACCESSORIES



EARTHING



OVERVOLTAGES

Link Vue System Electrical Safety (Surge Protection, Lightning Protection & Earthing)

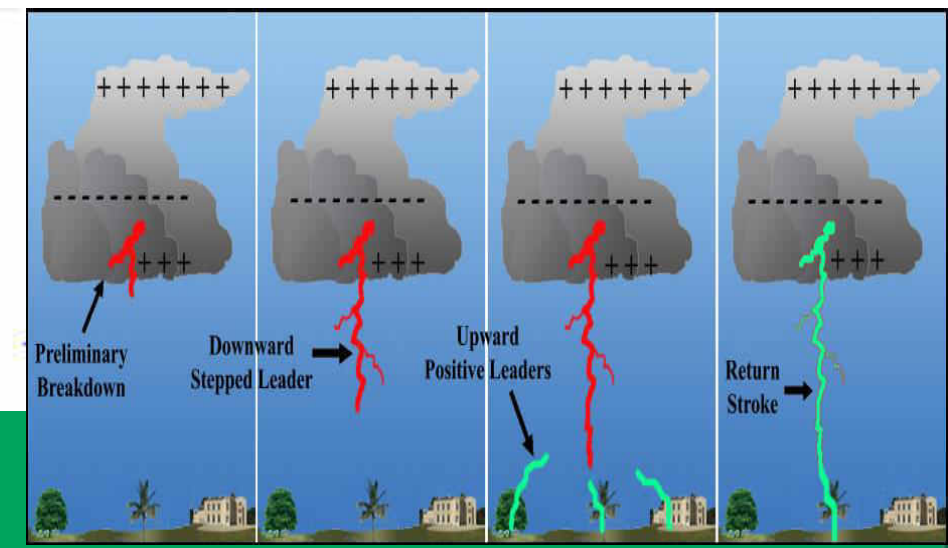
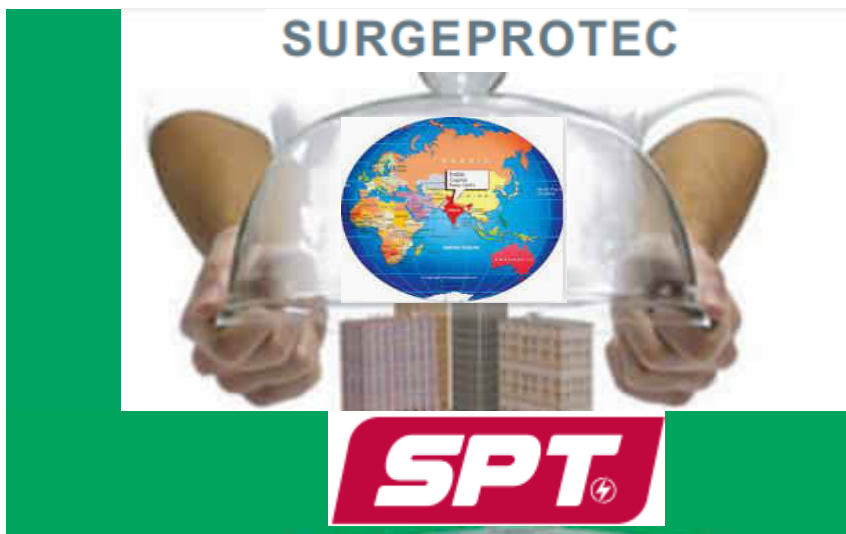
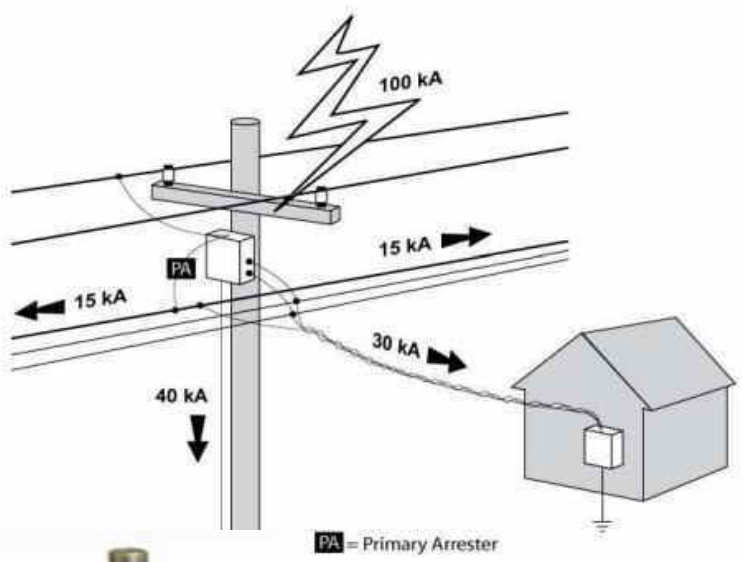

Lightning Equipotential Bonding Isolating Spark Gaps



Surge protection devices (SPDs) shall be provided for the main electrical distribution system including sub-switch boards and distribution boards, computers, electronic equipment, fire alarm panel, PABX equipment, UPS equipment, CCTV equipment, MATV equipment, card access equipment etc which are susceptible to lightning and switching surges.

Maintenance Free Earthing

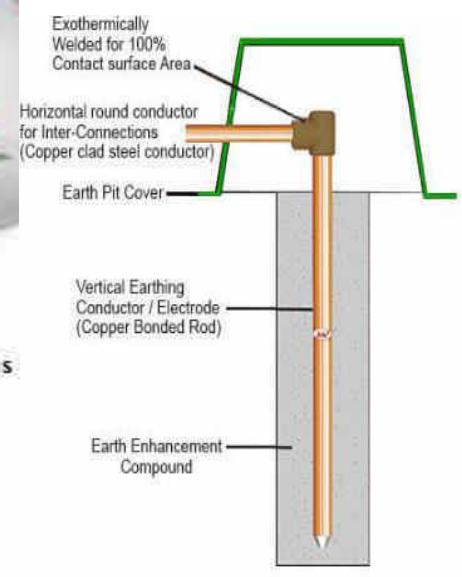

Surge Protection Device Market

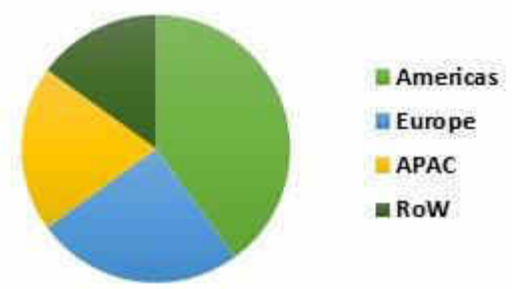



Products

Surge Protector



SPD PV - surge arrester

Combination of MOV and spark gap
PV Type 2 SPD
MOV surge arrester
UCPV 170 to 1500 V DC
In 15 to 20 kA
I_{max} 40 kA

Type 1 SPD-lightning current arresters

Combined, spark gap and MOV
I_{imp} 25 kA / 100 kA U_p ≤ 1.5 kV
No follow current, zero leakage current
Full coordination with Type 2 SPD



Type 2 SPD – surge arresters

Combined, spark gap and MOV
U_c 75 to 760 V AC
I_n 20 kA / I_{max} 40 kA
U_p ≤ 1.35 kV



Type 1 and 2 SPD -combined arresters B+C

Combined, spark gap and MOV
I_{imp} 12.5 kA / 50 kA
U_p ≤ 1.5 kV
No follow current, zero leakage current

Surge Protection Class B C and D as per Equipment Category

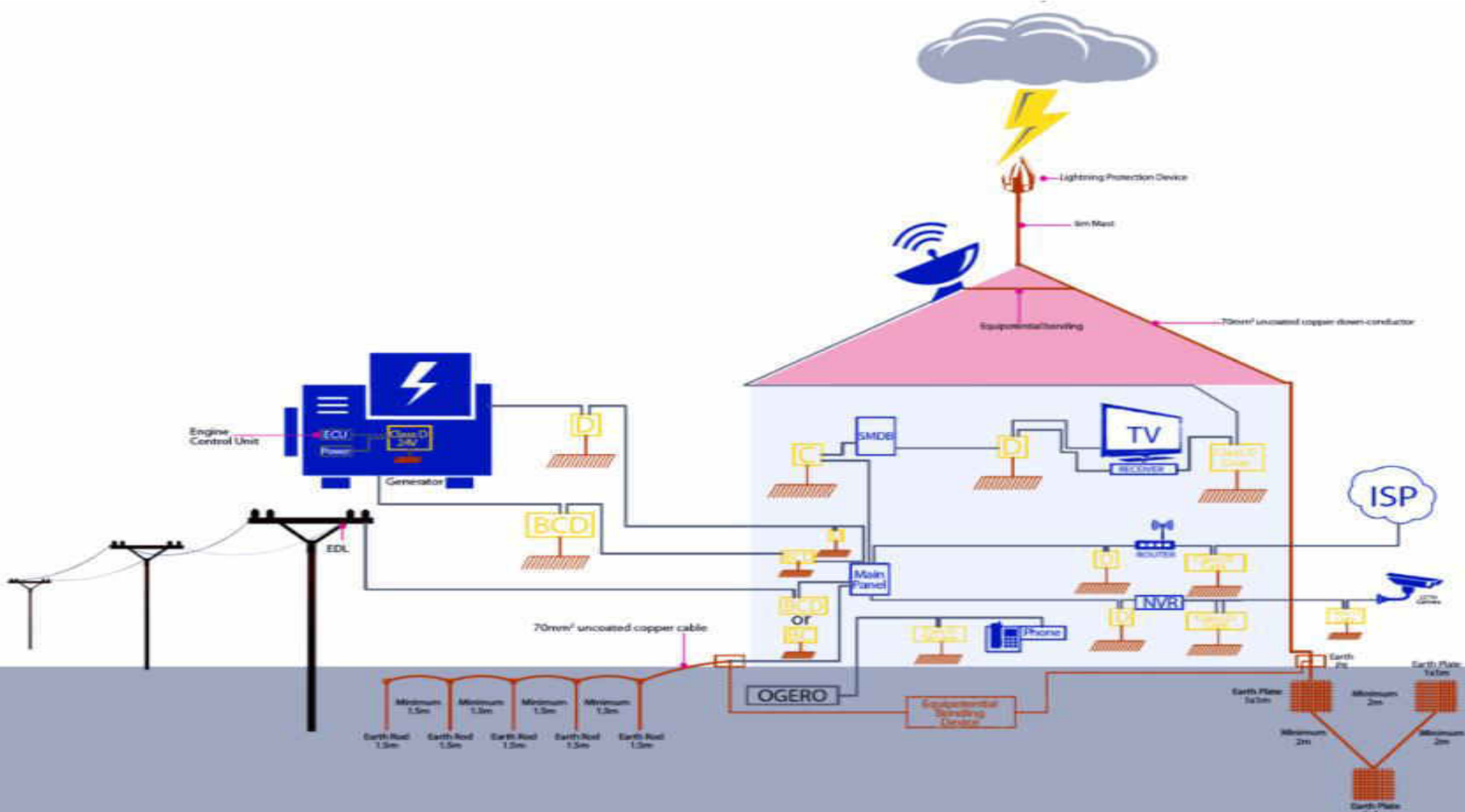

Surge Protection Installation Guide Line

7 MODULE (FULL MODE)

KA RATING 40KA PER PHASE (L-N, N-E, L-E)

SPD for power lines

7 module full mode protection

Monoblock type

Not interrupt the system

kA rating determine by the weakest link

Enclosed in rugged, safe, all metal enclosure

Provided with solid state indicators (LED)

Installed in parallel

Design to withstand multiple strikes

SPD for data/signal

Compatible & transparent to existing system

Not interrupt operation system

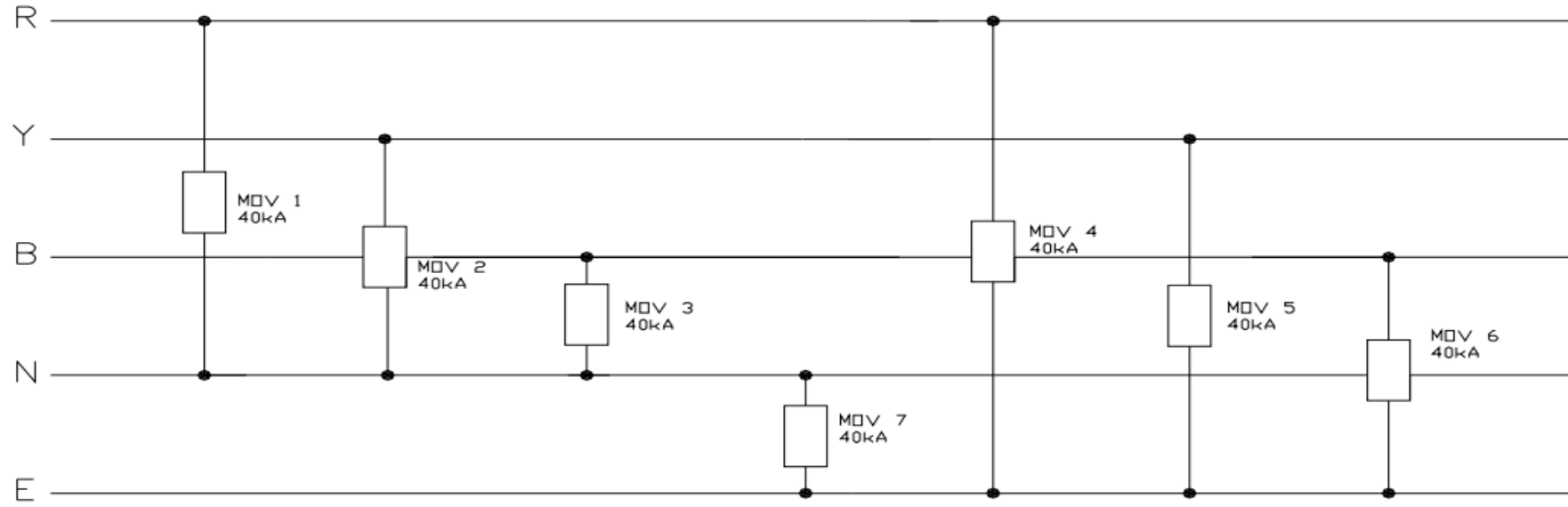

3 + 1 MODULE
NOT RECOMMENDED

7 MODULE (FULL MODE)

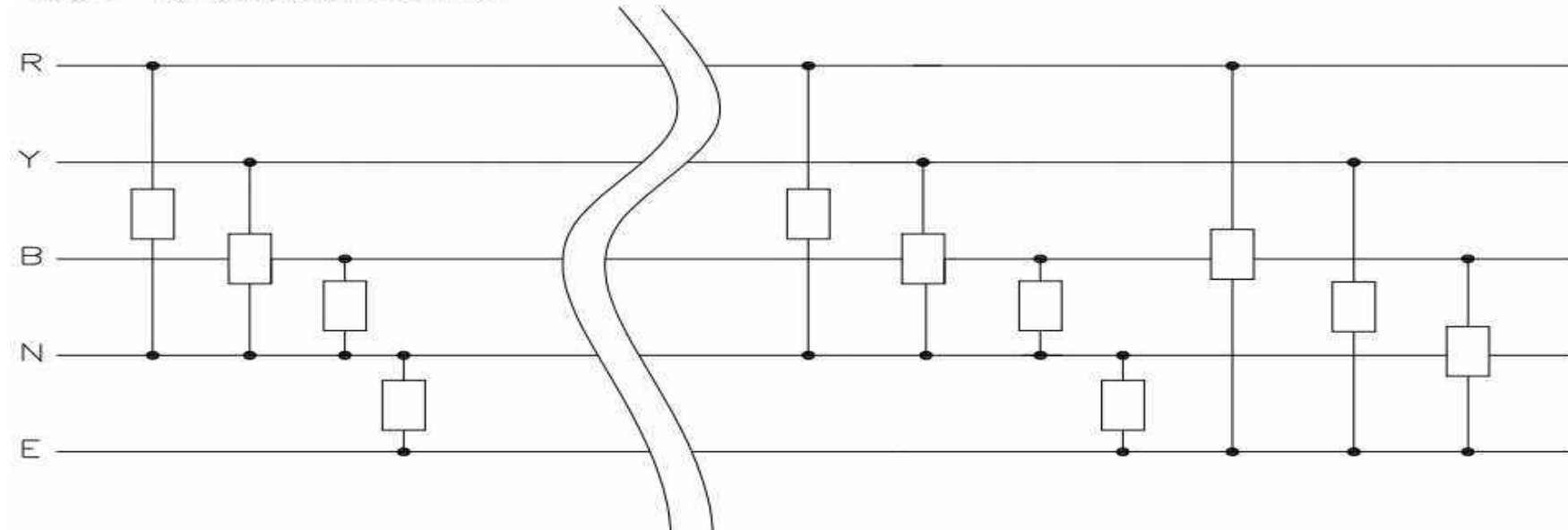

7 Modules		3 + 1 Modules	
1)	Protection between Live - Neutral, Live - Earth & Neutral - Earth	1)	Protection only between Live - Neutral & Neutral - Earth Only
2)	All MOV operates on its own rating	2)	The neutral to earth protection have more burden as all current will pass through this MOV irrespective of surge entrance and may damage faster
3)	Longer life cycle since more path for surge to travel to earth	3)	Less path for discharge current and weakest point at Neutral to Earth makes it life cycle shorter

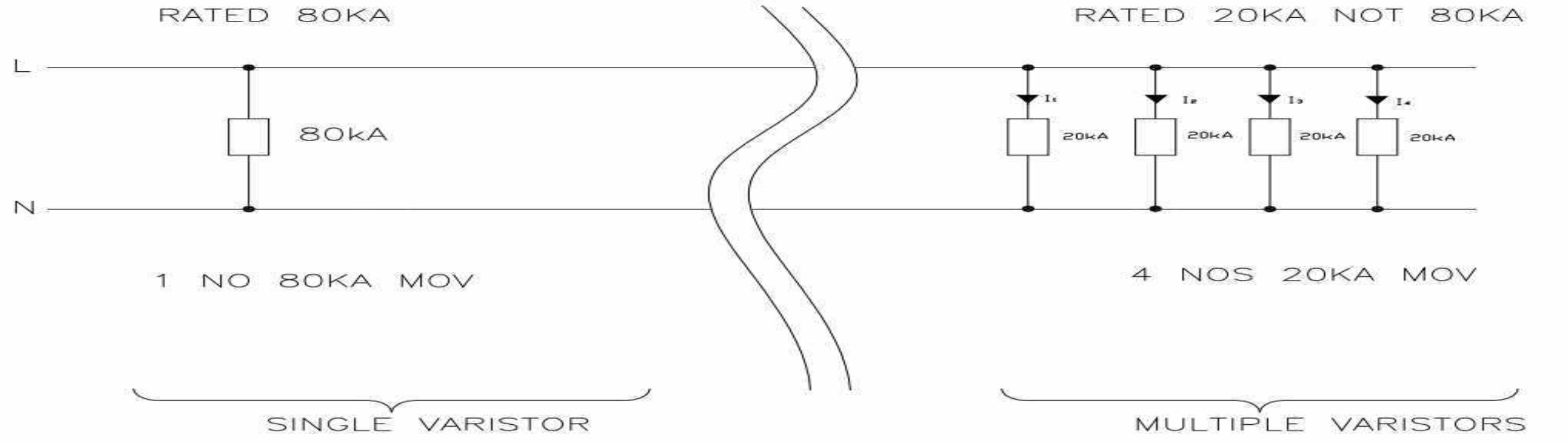

SURGE PROTECTION SELECTION FOR POWER SYSTEM

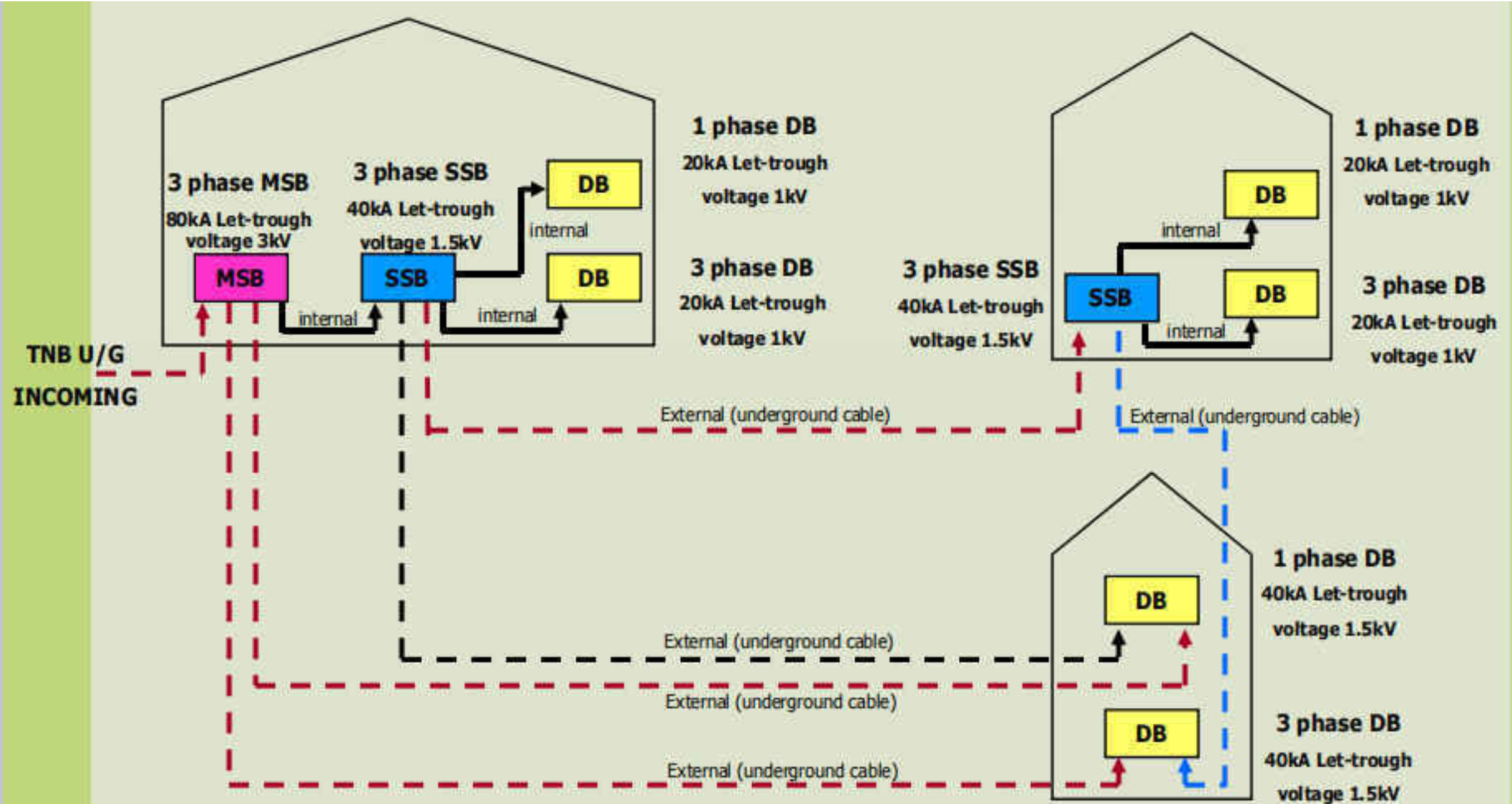

SURGE PROTECTION SELECTION FOR PABX SYSTEM

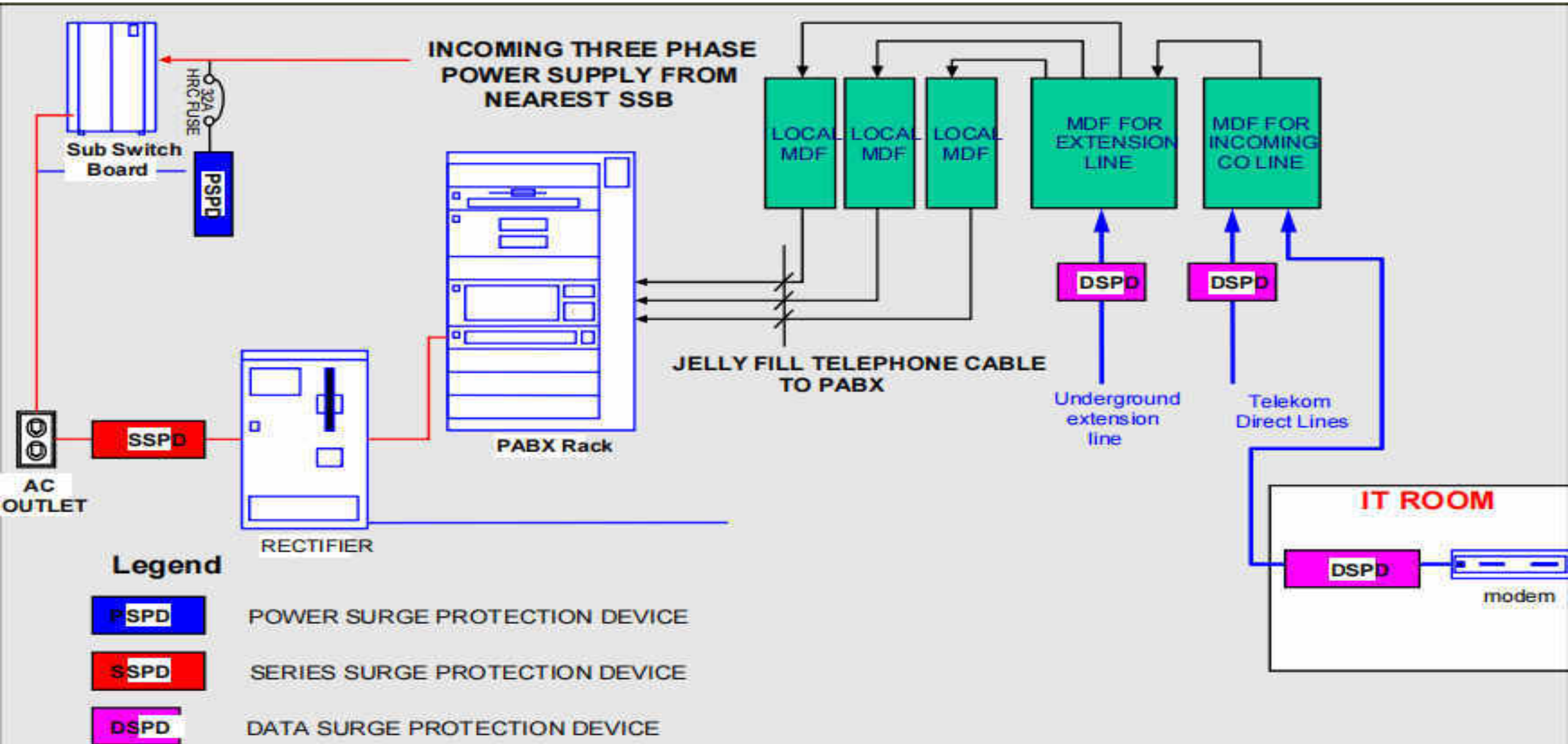

SURGE PROTECTION SELECTION FOR FIRE ALARM SYSTEM

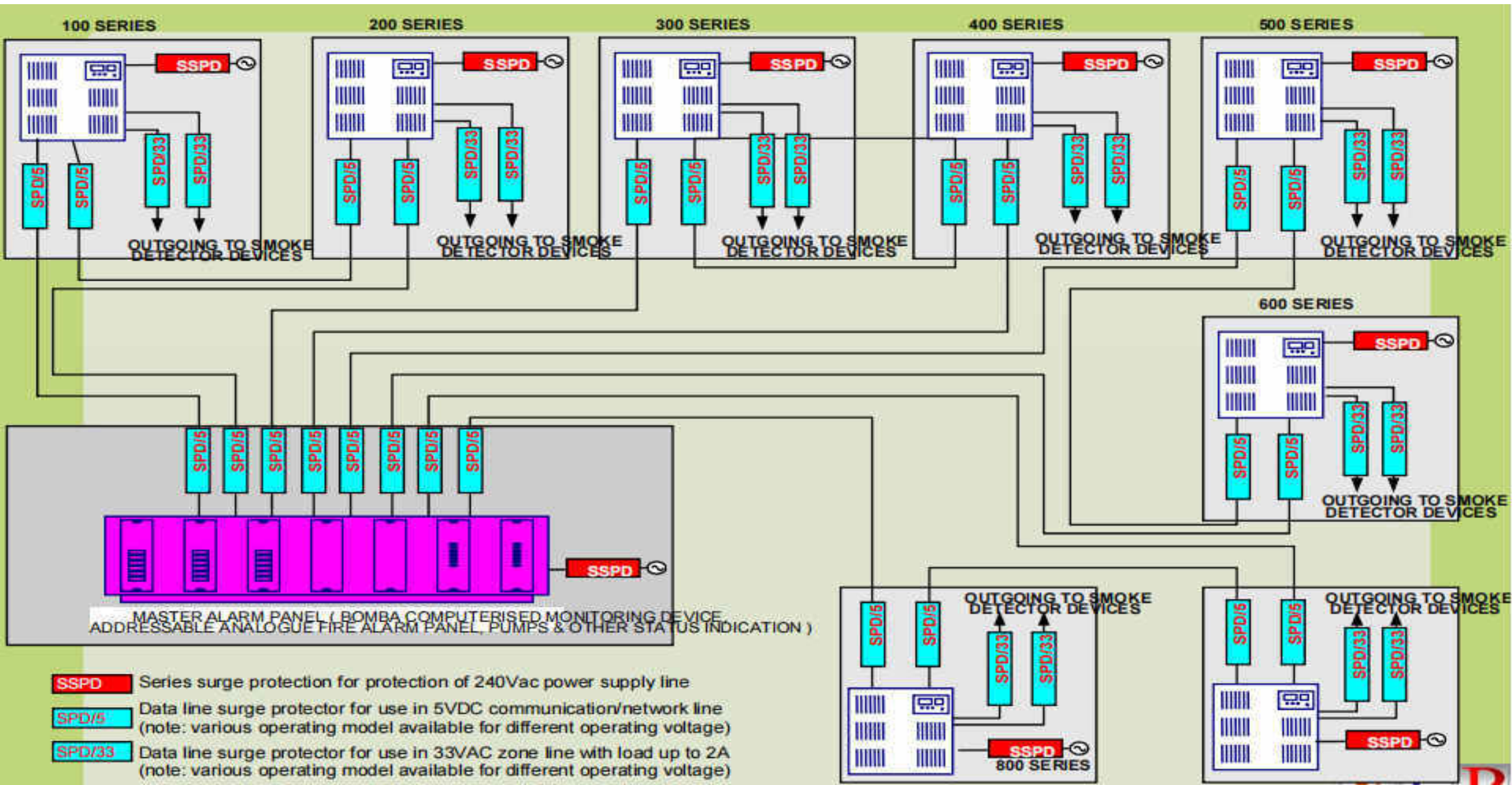

SURGE PROTECTION SELECTION FOR CCTV SYSTEM

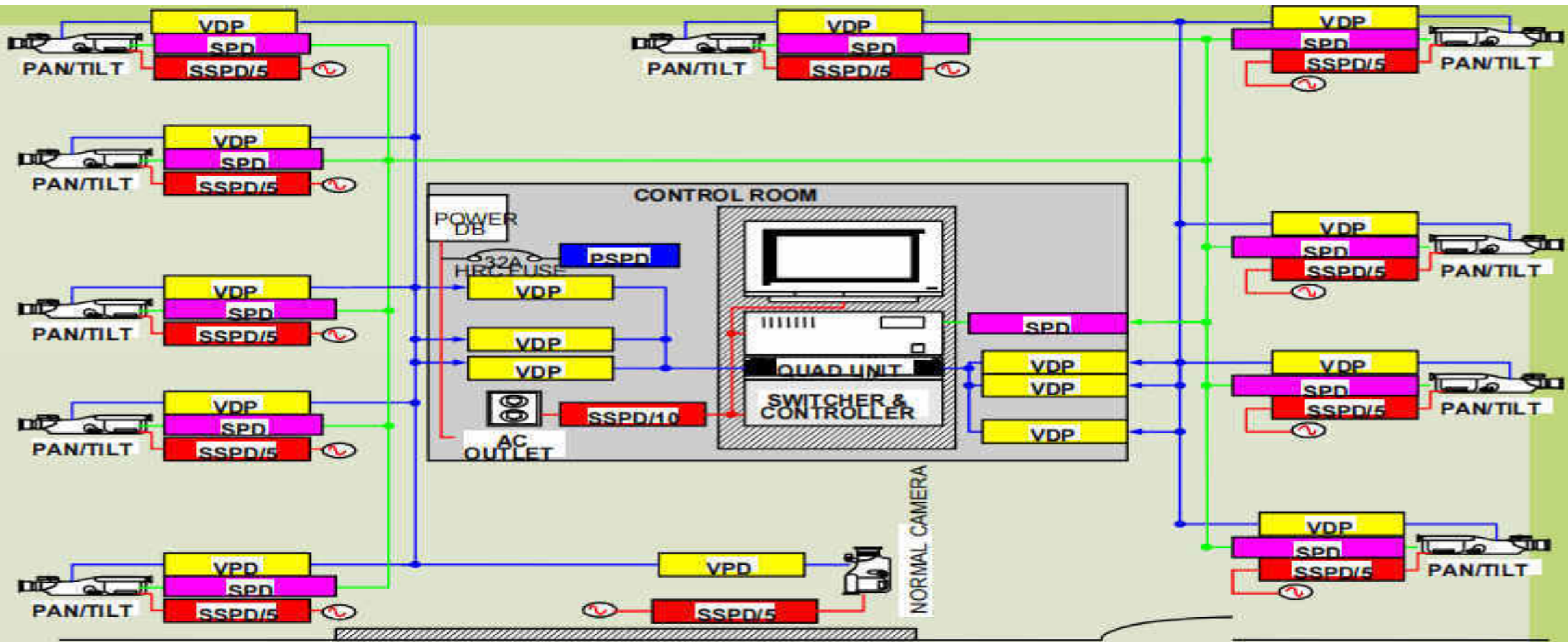

Legend

- PSPD POWER SURGE PROTECTION DEVICE
- SSPD/10 SERIES SURGE PROTECTION DEVICE FOR LOAD RATED 10A.
- SSPD/5 SERIES SURGE PROTECTION DEVICE LOAD RATED 5A.
- VDP VIDEO LINE SURGE PROTECTOR.
- SPD SIGNAL LINE PROTECTOR.

SURGE PROTECTION SELECTION FOR NETWORKING SYSTEM

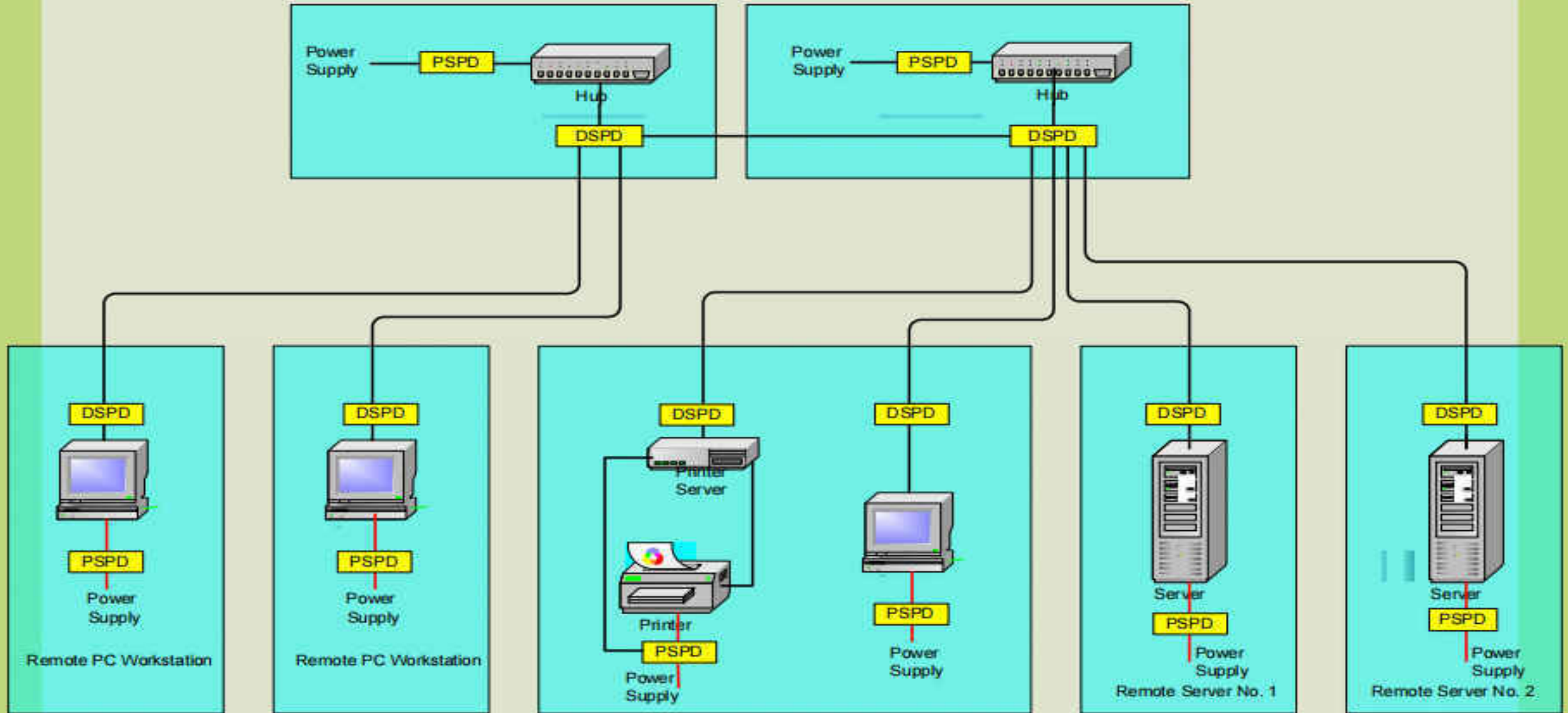

DSPD DATA SURGE PROTECTOR
PSPD POWER SURGE PROTECTOR

SURGE PROTECTION SELECTION

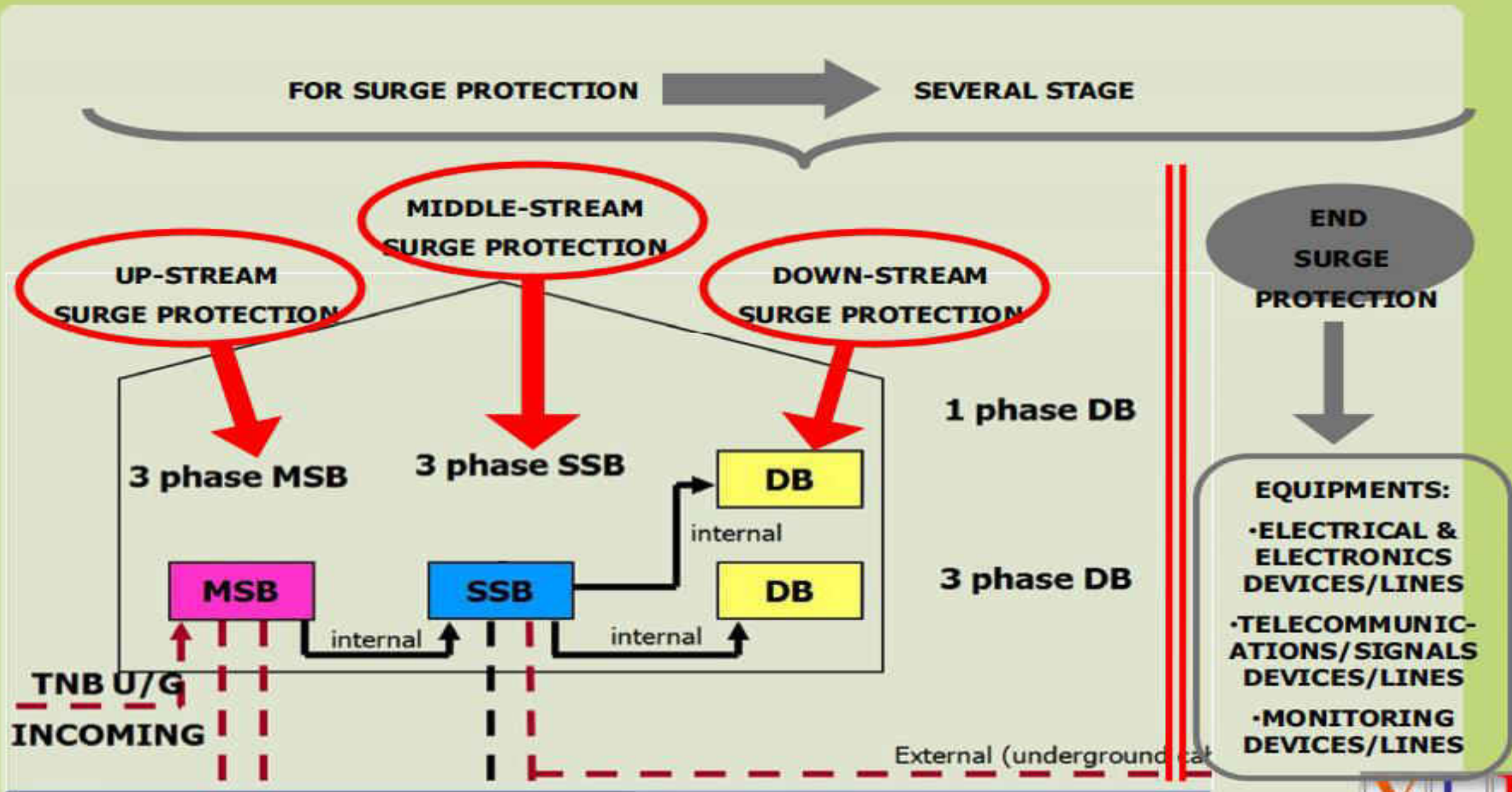

Surge Protection Installation for Multiple Equipments Safety

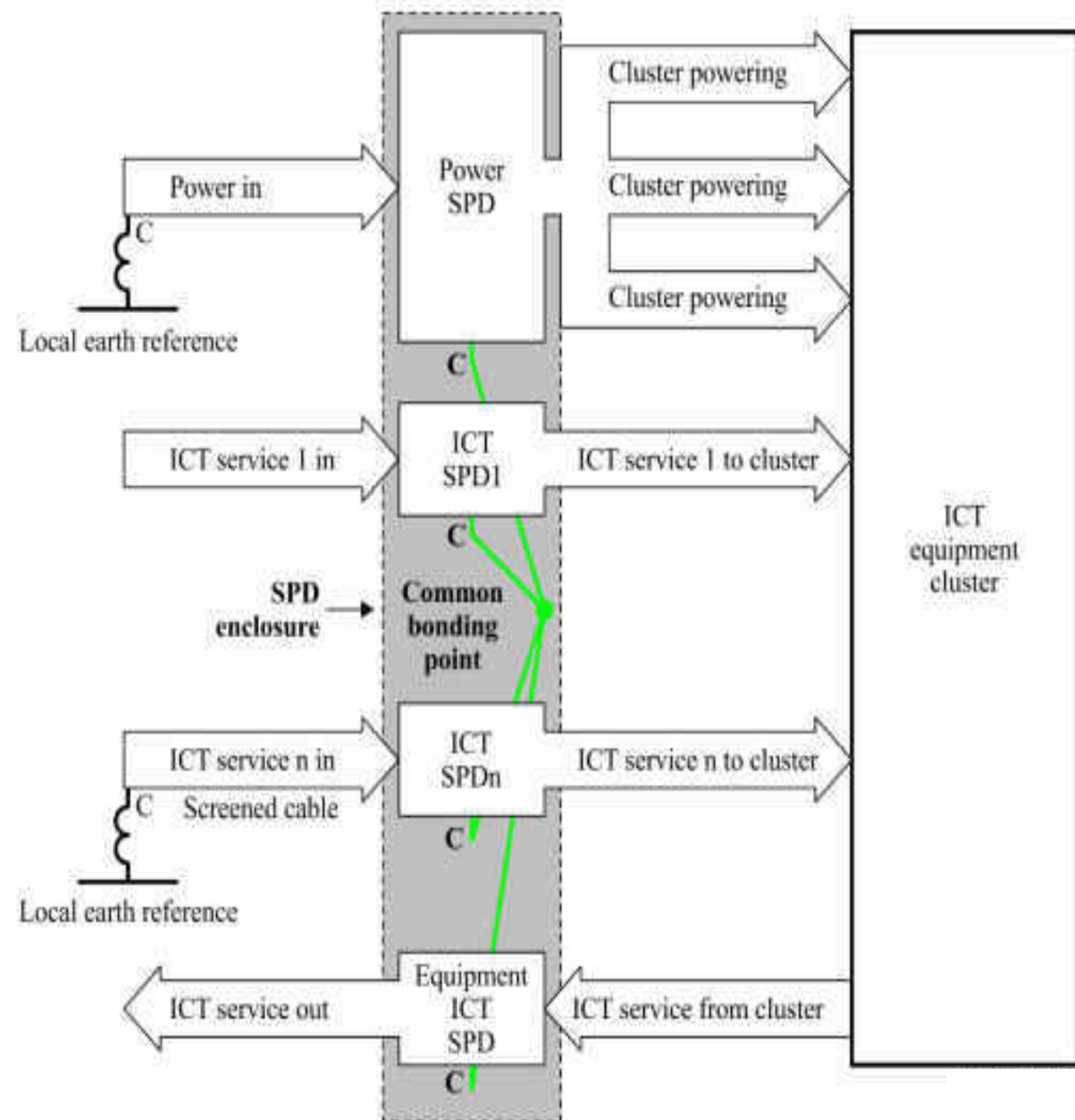

A surge reference equaliser does two things; it brings together all the service SPDs by locating them in a single enclosure and provides a local earth reference for all the SPD "C" terminals to directly connect to the common bonding point, or "star" connection has two external earth reference

One from the power SPD mains plug/socket local earth reference and the other from the screened cable remote earth reference. This means that the diverted surge current can split between the power and screened cable earth references. To avoid earth loops in normal operation, one SPDn option is to make the screened cable "C" connection to the common bonding point via an SPD with a switching function, which maintains isolation during normal conditions but provides a bond during the occurrence of a surge.

The surge reference equaliser is now called an MSPD, although there may not be any SPDs in it, only SPCs giving the equivalent surge functionality of the replaced SPDs.

MSPD for protecting power, antenna, telephone and Ethernet services with warning lights for protection failure and missing earth connection.

Surge Protection Installation for Multiple Equipments Safety

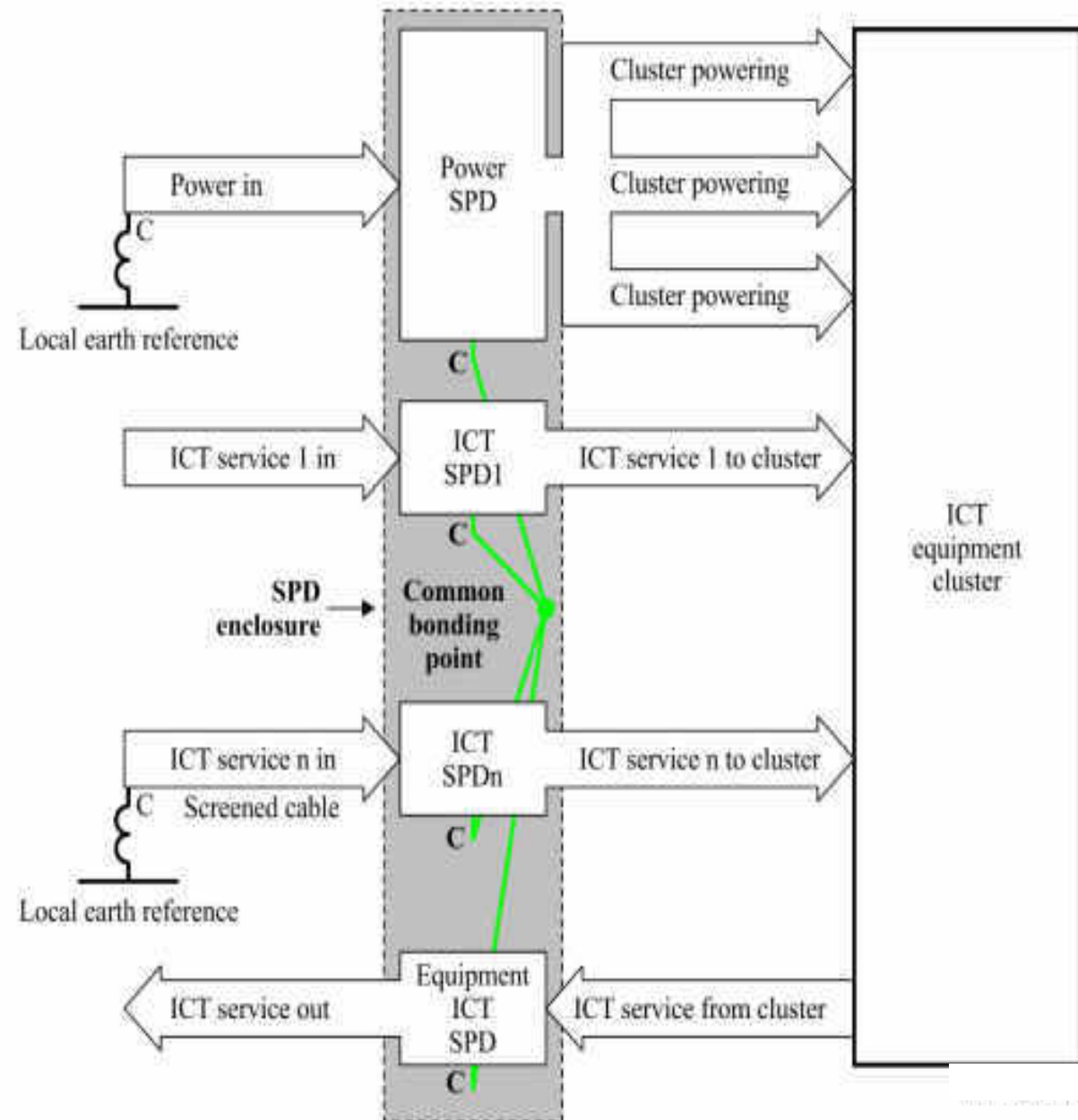

A surge reference equaliser does two things; it brings together all the service SPDs by locating them in a single enclosure and provides a local earth reference for all the SPD "C" terminals to directly connect to the common bonding point, or "star" connection has two external earth reference

One from the power SPD mains plug/socket local earth reference and the other from the screened cable remote earth reference. This means that the diverted surge current can split between the power and screened cable earth references. To avoid earth loops in normal operation, one SPDn option is to make the screened cable "C" connection to the common bonding point via an SPD with a switching function, which maintains isolation during normal conditions but provides a bond during the occurrence of a surge.

The surge reference equaliser is now called an MSPD, although there may not be any SPDs in it, only SPCs giving the equivalent surge functionality of the replaced SPDs.

MSPD for protecting power, antenna, telephone and Ethernet services with warning lights for protection failure and missing earth connection.

Surge Protection for Serial and Co-Axial Communication Port

All data, control and telephone cables entering and leaving the communications building require protection. The protection must be placed at the protection boundary and the protective earth connected to station earth. The aim is to divert energy at the boundary.

Data circuits require protection dependent upon their operating voltages and currents. Multistage series connected transient barriers should be employed. Figure 21 shows a typical schematic of Surge rating should be 20KA for an 8/20us impulse and the clamping voltage greater than the peak operating voltage.

Telephone lines require protection at the MDF. The protection should be multistage, when used with digital solid state telephone switches. Configuration will depend upon the termination method, eg KRONE[®], ADC, Reiche etc. Protect all incoming lines and external extensions. Generally internal extensions require no protection.

LAN systems require specialised protection specific to the LAN configuration. LAN line cards are particularly sensitive to transient overvoltage's and **MUST** be protected. Specialised protectors are available for the following protocols:

- RS232 in both DB9 and DB25 connector types
- RS485 and RS422 in DIN rail and DB9 configuration
- Thin Ethernet with in line and protected T BNC configuration
- Thick Ethernet with in line N type and DB15 AUI configuration
- RJ45 for UTP with hub protectors and individual terminal protectors

Ensure all LAN type protectors do not inhibit LAN performance. Only choose CAT5 UTP protectors.

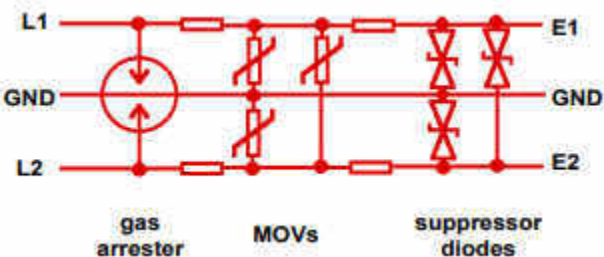

As well as the outer conductors of coaxial feeders the inner conductors must also have protection applied to divert energy on the inner conductor to ground. The application of surge protection to UHF and microwave circuits is limited by frequency, return loss and insertion loss considerations. Typical coaxial surge protectors consist of a fast acting gas filled arrester connected between line and ground. Figure 19 shows a typical coaxial surge protector for type N connectors. This is a bulkhead mounting type.



Arrester flashover voltage should equal twice the peak line voltage. Example in a 50 ohm line with 50W transmitter, peak voltage = 70.7V. Minimum recommended gas arrester BV = 140V. Nearest value = 230V. Surge rating should be 20KA for an 8/20us impulse.

Gas filled arresters are unsuitable for high power HF and VHF transmitters ($\geq 1KW$) unless the transmitters incorporate return power shutdown circuitry. A gas filled arrester once fired will remain in the conducting state by the presence of RF energy. This will destroy the arrester unless the transmitter has shutdown circuitry which detects the impedance discontinuity.

Alternatively utilise spark gap arresters with arc detection and shutdown circuitry.

For microwave link equipment an alternative and more effective solution is the quarter wave stub protector. These units must be tuned to the frequency in use but are capable of reasonably large bandwidth. For example a quarter wave stub protector centred on 2.4GHz has a usable bandwidth of $\pm 100MHz$. Figure 20 shows a typical unit.



Let's STUDY Jointly reason of Surge and use of Surge Protection including Installation GuideLine with Wiring Rules

UL SPD Types - Per 1449 4th Edition

Type 1- One port. permanently connected SPDs, except for watt-hour meter socket enclosure, intended for installation between the secondary of the service transformer and the line side of the service equipment overcurrent device, as well as the load side, including watt-hour meter socket enclosures and Molded Case SPDs intended to be installed without an external overcurrent protective device. Type 1 SPDs for use in PV systems can be connected between the PV array and the main service disconnect.

DIN-RAIL SPDs are open Type 1.

Type 2- Permanently connected SPDs intended for installation on the load side of the service equipment overcurrent device, including SPDs located at the branch panel and Molded Case SPDs.

Type 3 - Point of utilization SPDs, installed at a minimum conductor length of 10 meters (30 feet) from the electrical service panel to the point of utilization, for example cord connected, direct plug-in receptacle type and SPDs installed at the utilization equipment being protected. See marking in 80.3. The distance (10 meters) is exclusive of conductors provided with or used to attach SPDs.

Note: type 2 and 3 SPDs were previously known as TVSSs,

Type 4 - Component Assemblies - Component assembly consisting of one or more Type 5 components together with a disconnect (integral or external) or a means of complying with the limited current tests in 44.4.

Type 1, 2, 3 Component Assemblies - Consists of a Type 4 component assembly with internal or external short circuit protection.

Type 5 - Discrete component surge suppressors such as MOVs that may be mounted on a PVVB connected by its leads or provided within an enclosure with mounting means and wiring terminations. V/U_n ---nominal system voltage.

A nominal value assigned to designate a system of a given voltage class in accordance w ANSI CB4,1. Typical voltages include 120, 208, 240, 277, 347, 480, 6000 Vac.

V --- Voltage Protection Rating A ring selected from a list of preferred values as given in Table 63.1 of UL 1449 4th Edition and assigned to each mode of protection. The value of V is determined as the nearest highest value taken from Table 63.1 to the measured limiting voltage determined during the surge test using the combination wave generator at a setting of 6 kV, 3kA. It is also known as let-through voltage.

Guide to Surge Protection Devices (SPDs): selection, application and theory

The following common terminologies, as recognised by BS EN 61643/IEC 62305 are used throughout SPD specifications in order to aid correct selection and are defined as follows:

Nominal Voltage U_0 is the line voltage to Earth a.c. voltage of the mains system (derived from the nominal system voltage) for which the SPD is designed to is the voltage by which the power system is designated -e.g. 230V.

Maximum Continuous Operating Voltage U_c is the maximum RMS voltage that may be continuously applied to the SPD's mode of protection e.g. phase to neutral mode. This is equivalent to the SPD's rated peak voltage.

Temporary Overvoltage U_T is the stated test value of momentary voltage increase or overvoltage that the power SPD must withstand safely for a defined time. Temporary overvoltages, typically lasting up to several seconds, usually originate from switching operations or wiring faults (for example, sudden load rejection, single phase faults) as well as mains abnormalities such as ferro-resonance effects and harmonics.

Impulse Current I_{imp} is defined by three parameters, a current peak with a charge and a specific energy typically simulated with the 10/350 μ s waveform to represent partial lightning currents. This waveform is used with peak I_{imp} current value stated. for the mains Type 1 SPD Class I test and typically for data telecom SPD Test Category D.

Nominal Discharge Current I_{nspd} is a defined nominal peak current value through the SPD, with an 8/20 μ s current waveshape. This is used for classification of mains SPDs (Class II test) and also for preconditioning of SPDs in Class I and Class II tests.

Maximum Discharge Current I_{max} is the peak current value through the SPD, with an 8/20 μ s waveshape. I_{max} is declared for mains Type 2 SPDs in accordance to the test sequence of the Class II operating duty test. In general, I_{max} is greater than I_{nspd} .

Surge protective devices (SPDs) Surge protective devices mainly consist of voltage-dependent resistors (varistors, suppressor diodes) and / or spark gaps (discharge paths). Surge protective devices are used to protect other electrical equipment and installations against inadmissibly high surges and / or to establish equipotential bonding. Surge protective devices are categorised:

Surge protective devices for power supply installations and devices for nominal voltage ranges up to 1000 V

- according to EN 61643-11:2012 into type 1 / 2 / 3 SPDs
- according to IEC 61643-11:2011 into class I / II / III SPDs

Surge protective devices for information technology installations and devices

for protecting modern electronic equipment in telecommunications and signalling networks with nominal voltages up to 1000 V AC effective value) and 1500 V DC. against the indirect and direct effects of lightning strikes and other transients.

- according to IEC 61643-21:2009 and EN 61643-21: 2010.

Isolating spark gaps for earth-termination systems or equipotential bonding

Surge protective devices for use in photovoltaic systems

for nominal voltage ranges up to 1500 V

- according to EN 50539-11:2013 into type 1 / 2 SPDs

impulse current discharge capacity and protective effect into:

Lightning current arresters / coordinated lightning current arresters

for protecting installations and equipment against interference resulting from direct or nearby lightning strikes

Surge arresters

for protecting installations, equipment and terminal devices against remote lightning strikes, switching over-voltages as well as electrostatic discharges (installed at the boundaries downstream .

Combined arresters

for protecting installations, equipment and terminal devices against interference resulting from direct or nearby lightning strikes (installed at the boundaries between LPZ 0A and 1 as well as 0A and 2).

Technical data of surge protective devices

The technical data of surge protective devices include information on their conditions of use according to their:

Application (e.g. installation, mains conditions, temperature)

Performance in case of interference (e.g. impulse current discharge capacity, follow current extinguishing capability, voltage protection level, response time)

Performance during operation (e.g. nominal current, attenuation, insulation resistance)

Performance in case of failure (e.g. backup fuse, disconnecter, failsafe, remote signalling option)

Short-circuit withstand capability

The short-circuit withstand capability is the value of the prospective power-frequency short-circuit current handled by the surge protective device when the relevant maximum backup fuse is connected upstream.

Short-circuit rating ISCPV of an SPD in a photovoltaic (PV) system

Maximum uninfluenced short-circuit current which the SPD, alone or in conjunction with its disconnection devices, is able to withstand.

Temporary overvoltage (TOV)

Temporary overvoltage may be present at the surge protective device for a short period of time due to a fault in the high-voltage system. This must be clearly distinguished from a transient caused by a lightning strike or a switching operation, which last no longer than about 1 ms. The amplitude U_T and the duration of this temporary overvoltage are specified in EN 61643-11 (200 ms, 5 s or 120 min.) and are individually tested for the relevant SPDs according to the system configuration (TN, TT, etc.). The SPD can either a) reliably fail (TOV safety) or b) be TOV-resistant (TOV withstand), meaning that it is completely operational during and following temporary over-voltages.

Sparkgap Protection

Spark gaps are intended to provide galvanic isolation between electrical installation parts where direct connections are not permitted. The galvanic isolation prevents not only electrochemical corrosion but provides also a connection capable of carrying lightning current. For connecting different earthing systems, the aim being to make optimum use of all earthers for lightning protection equipotential bonding.

Earthing Distance Maximum 500mtr allowed for Electrical and 300mtrs allowed for Low Voltage Equipment's.

Shortest Discharge Path , Less Joints No Sharp Bend ,Round Conductor for routing Earthing up to Equipment's, all buried Joint should be Exothermic Weld

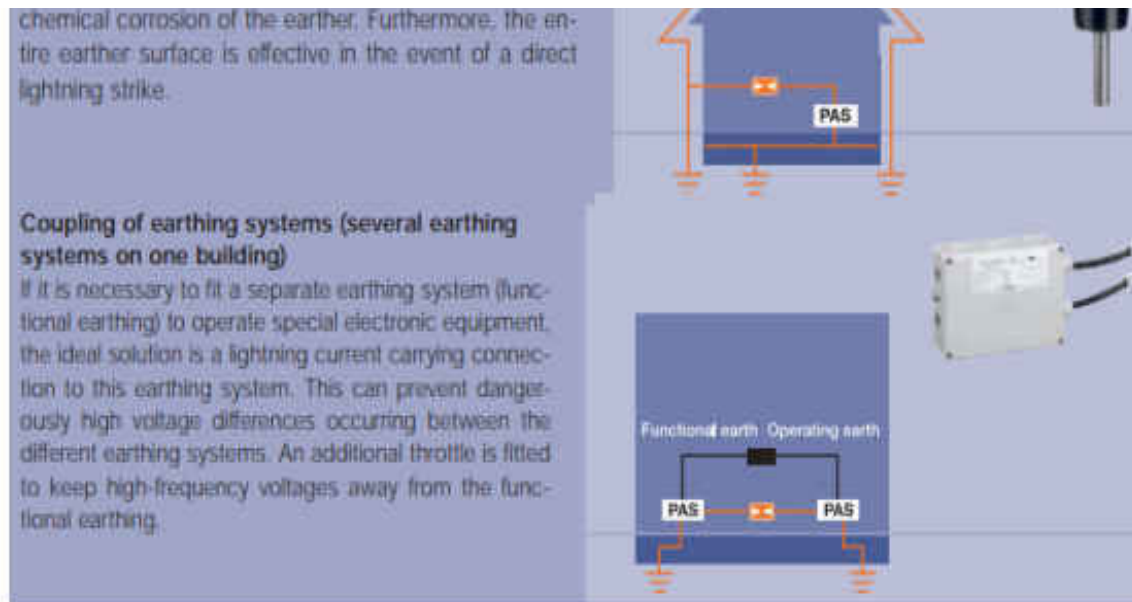



Director:- Mr. Manish Khatri

Head Marketing & Sales:- Mr. Mahesh Chandra Manav

Link Vue Systems Pty Ltd

2 BRUCE STREET, BLACKTOWN NSW 2148,

Sydney, Australia Mobile:+61-423064098, Mobile: +91-9811247237,

[Email:manav.chandra@linkvuesystem.com](mailto:manav.chandra@linkvuesystem.com)

visit webpage www.linkvuesystem.com

Link Vue System Pvt Ltd

India Office: I-19, Karampura, New Moti Nagar, New Delhi, (India).

Mobile: +91-9811247237

Tel: +91 11 4559778

[Email:manav.chandra@linkvuesystem.com](mailto:manav.chandra@linkvuesystem.com) [Email:manish@linkvuesystem.com](mailto:manish@linkvuesystem.com) Website: www.linkvuesystem.com



Link Vue

INT: INDIA/AUSTRALIA

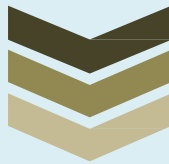

Right Solution Partner for your Problems  A Genuine Approach Latest Technologies Adoption

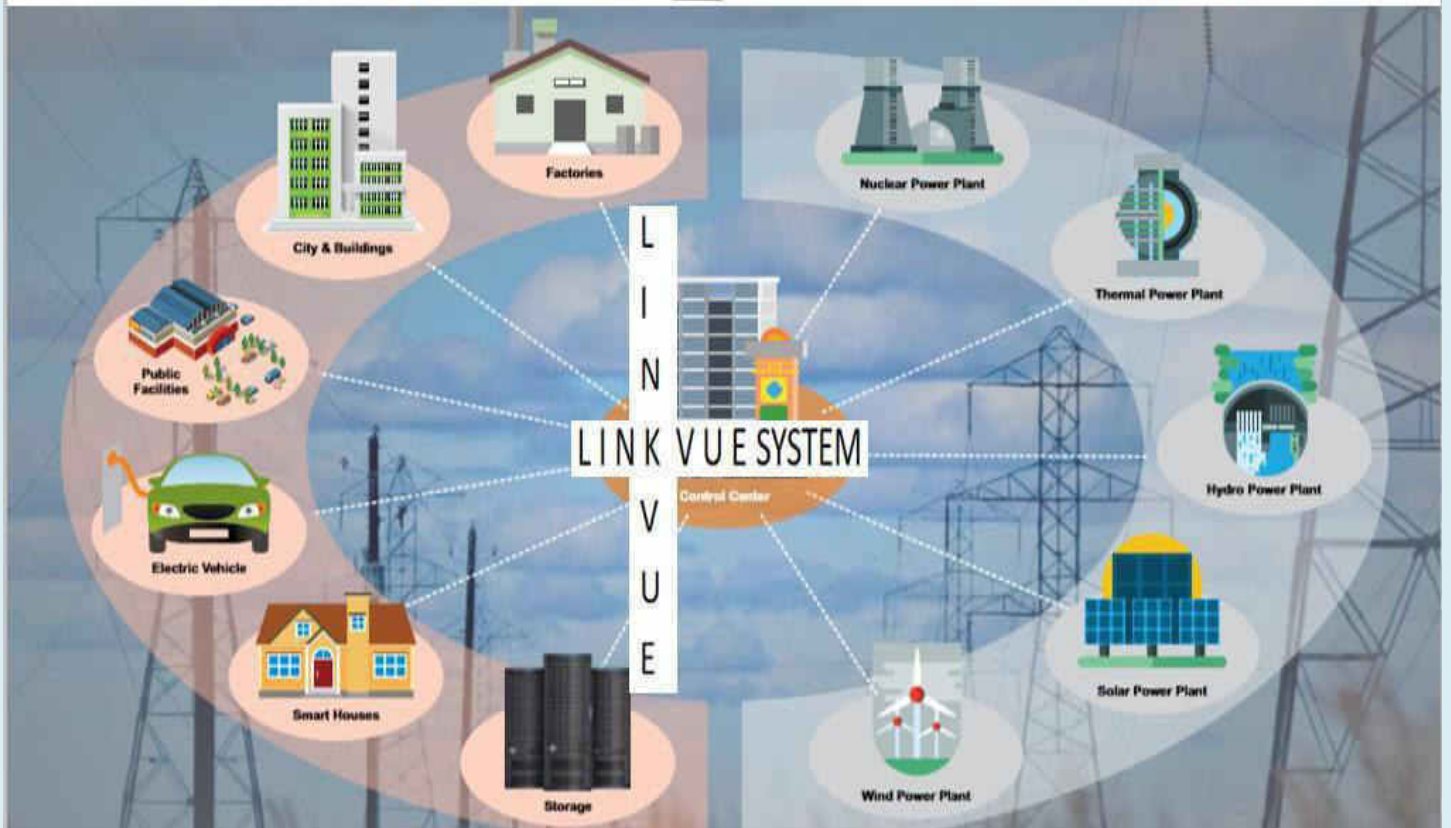

India

Australia

Link Vue System Pvt Ltd (A Genuine Approach & Technology Company)



Link Vue System Pvt Ltd (A Genuine Approach & Technology Company)



Link Vue System Pvt Ltd (A Genuine Approach & Technology Company)



Solution Partner for your every Customers
with Technolgy and Genuine Products

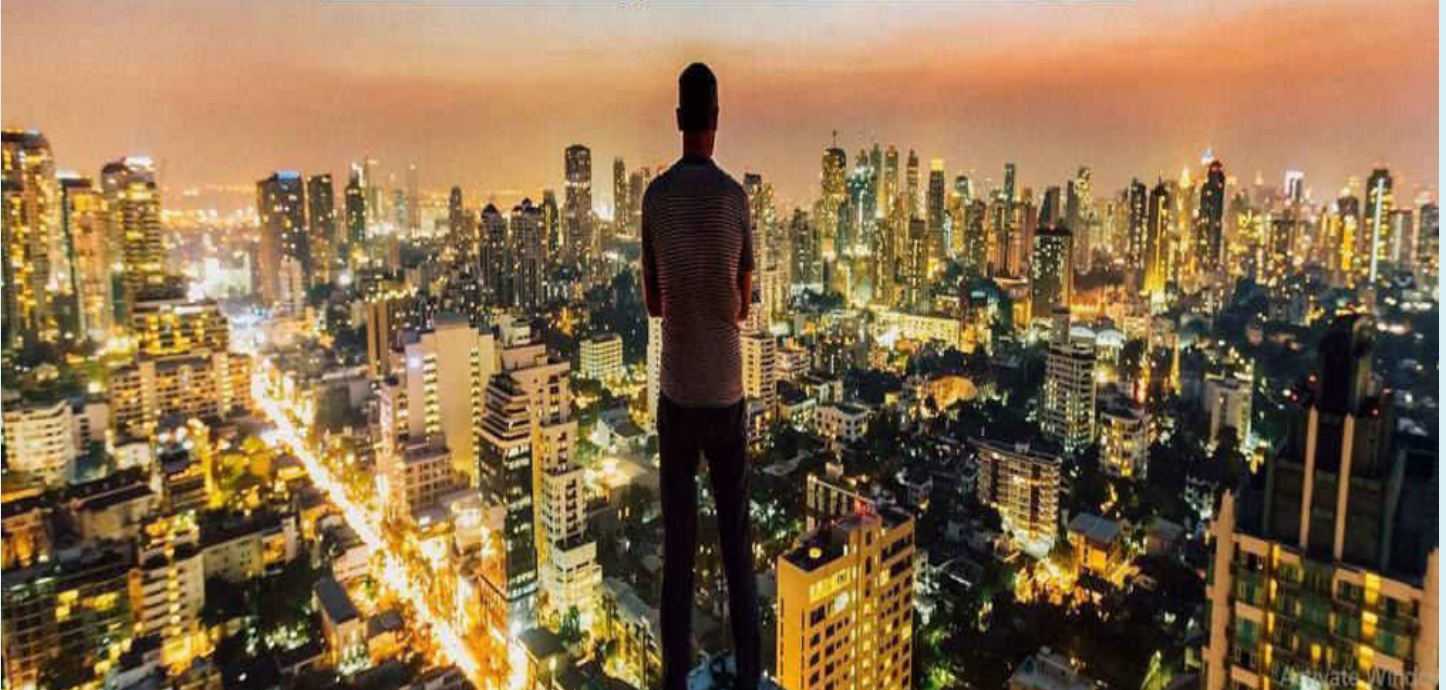

We offer end to end engineering solutions from project conceptualization, engineering design, Constancy with incorporates our own In-house Singapore brand of Ethernet M2M connectivity wide range of products with International industries approvals of CE, FCC & ROHS standards, Moreover We are the strategic partners, sole distributors for world' leading Enterprise ICT & Industrial class Surveillances security products from products selection to project commissioning services for industries assisted with onshore & offshore 24X7 service support Link Vue System Private Limited - India established to provide premier Integrated solutions for Industrial & Enterprise Grade Ethernet Connectivity / Wireless WLAN, GSM Technology incorporates value added supply services & End to End support for Govt.& small to large businesses to plan, build deploy & manage their Industrial Automation SCADA communication control, Ethernet LAN/WAN networks System infrastructure, CCTV Surveillances, Access Control as per their standards - all within their stipulated budget and cost effective solution.

With our extensive knowledge & rich industry hands-on experience in the Networks communication & Industrial Automation arena, we continuously innovate and upgrade our products range aimed the varied applications needs of our customers, we maintain high quality standards for our offering products which we have received many quality and testing certifications from industries internationalcertifications bodies.

<p>VIRTUALIZATION Centralization. Consolidation. You've got a long list of what ifs" and "must havees." We'll sit down with you and really listen to your needs, then design systems that perform optimally, increase productivity and reduce costs.</p> <p>IT & INDUSTRIAL COMMUNICATION BRAINS Our clients are supported by our staff of experts plus a resource network of Level 1 to Level 3 engineers. We'll make sure we address your problems economically and strategically We perfect your systems before you even see them.</p> <p>IMPLEMENTATION AND SUPPORT We don't drop off the parts and walk out the back door We manage the project through implementation and then follow up to make sure everything is working correctly. We see value when it's built into long-term success.</p> <p>Who is Link-Vue? We are, of course It's our passion to deliver peace of mind. Learn more about Link-Vue integrated IT products and solutions</p>	<p>Services & Supports</p> <ul style="list-style-type: none"> • AMC/ CAMC • IT Technical Support Help Desk • Server Implementation • Hardware Repair Services • Software Configuration • Architecture & Implementation • Problem Remediation& Rectification •Hardware Repair Services • Project design & consultancy • Asset Management • Warranty Services
---	---

Performance Enabling Solutions

- Advanced CCTV Surveillances & Access control Security on Ethernet Platform
- Industrial & Enterprise Networking LAN/WAN, Wireless WLAN & GSM Data Loggers.
- IP Security Collaboration I Messaging Mission Critical Data Storages NAS /GRID
- Industrial Automation DCS I PLC I SCADA HMI I Industrial Computers Products & Implementations
- Consultancy in Enterprise and Industrial Automation Networks Design
- Sourcing of best Components Supply from in-house brand/ customized based on the project requirements for industrial and enterprise connectivity and automation verticals.
- IT Data Centre and ICT Products Infrastructure Management.

City Surveillance

Empowering Vigilance



Activate Window
Go to settings to acti





Take your equipments online

The next generation IIoT platform

marc is our next generation GSM/LAN based IIoT platform with built in apps for **assets and equipment** for managing efficiency, uptime, productivity, condition monitoring, control, preventive & predictive maintenance.

marc.gateway
Advanced wireless communication with offline storage

Redundant & fault tolerant cloud
Secure & Scalable

marc
Actionable analytics
Real-time monitoring
Customized reports & trends

Available on the App Store and Google Play.

Logging
Alerting, Log to, Historize & Analyze Alerts

Actionable analytics
Asset health, Predictive maintenance, benchmarking & goal setting

Customized reports & trends
Energy, Inventory, Stock, Faults & Alerts

Alarms & notifications
SMS & Email

Redundant & Fault tolerant

Secure & Encrypted

High speed Wireless communication

Offline data storage

Available on the App Store and Google Play.

Supported Protocols - Modbus TCP/IP, Modbus RTU, MQTT, Https

Applications	Why IIoT?
Energy & Utility <ul style="list-style-type: none"> Energy Management Transformers Monitoring Industrial Motor HVAC Monitoring Smart Energy Audit Energy Audit Water Management Water Audit 	<ul style="list-style-type: none"> Efficiency Uptime Productivity Availability Service Condition Alert Prevention Prediction
Plant & Process <ul style="list-style-type: none"> Equipment or Asset Monitoring Process Monitoring Machine Monitoring OEE Other Agriculture, Vehicle Weather Smart City Custom Application development 	<p>Access the window to the settings to activate</p>

Design for harsh industrial environments
stable and reliable

- ✓ Industrial Level 4
- ✓ IP40 protection
- ✓ CE, FCC certified
- ✓ Anti-EMI



LINK VUE



Industrial & Commercial Managed Gigabit POE / Unmanaged Switches & Media Convertors Models Series

More than 100 different RJ45 Copper & LC/ST/SC Fiber ports models available.

Physical Characteristics

Housing: Aluminum Alloy material with IP40 Protection
Very light weight
Rack mount, wall mount & Din Rail

Interfaces

Console Port: rs-232(RJ45 connector)
Web GUI Interfaces
Alarm Contact: 1 replay outputs, supports IP/MAC conflict



Power

Input Voltage: 220V AC (110-240V AC)@2A / (12-24) VDC Redundant dual inputs
Plug-In Terminals: 5 Cores 5.08mm Terminals
Overload Current Protection: Present
Reverse Polarity Protection: Present
Redundant Protection: Present
Connection: 1 removable 8-pin terminal blocks

Environmental Limits

Operating Temperature: -40 + 85 degree C
Storage Temperature: -40 + 85 degree C
Ambient Relative Humidity: 5%-95% (non-condensing)

EMS

EN61000-4-2 (ESD) Level 3
EN61000-4-3 (RS) Level 3
EN61000-4-4 (EFT) Level 3
EN61000-4-5 (Surge) Level 3
EN61000-4-6 (CS) Level 3
EN61000-4-16(Common-mode Conduction) Level 3
Shock: IEC 60068-2-27
Free Fall: IEC 60068-2-32
Vibration: IEC 60068-2-6
EMI: FCC CFR47 Part 15, EN55022/CISPR22, Class A
Industry: I EC60068-2-6, I EC60068-2-27, I EC60068-2-32
Rail: EN501 55, EN501 21 -4
Traffic: NEMA TS-2



5 Years
International Warranty

BMS Network Infrastructure System



- Backbone Routing & switching
- LAN & WAN Controllers to PLC connectivity.
- CCTV Surveillances, Access control temaserver: & Fire Alarm connectivity.
- Servers & Workstation implementations.
- IT Data Center management & control monitoring
- Network Monitoring Systems (NMS) Implementation.

Oil, Gas & Process Industries



- CCTV Surveillances security incorporates.
- Ethernet LAN Networks infrastructure parameter boundary for Refinery division.
- CCTV Solution for Explosion & hazardous zone areas.
- Explosion Proof (ATEX) approved CCTV for pipeline automation.

Solar Surveillances Scada Network Systems



- CCTV Surveillances Plant field Area.
- SCADA Control room implementation.
- Ethernet Communication, Fiber optics splicing
- All Kind of LAN / WAN Implementations.
- GSM Data Loggers & RTU Communication.
- GSM celluiler, Serial, Ethernet Data logger for solar power application.
- Progamebe using IEC 61131-3 languages.

Power Networks Infrastructure

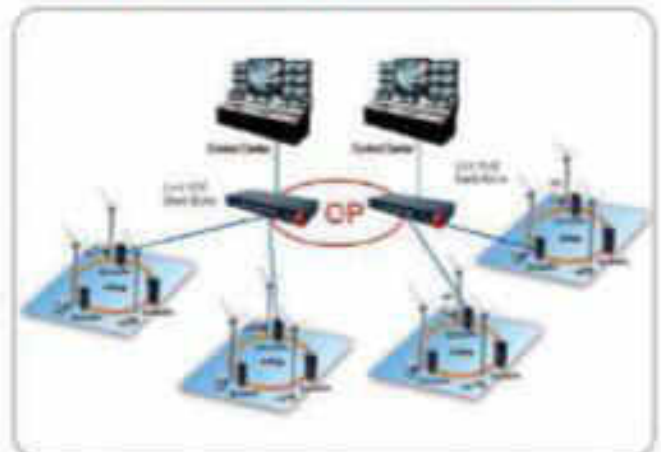

- Real IT & Industrial connectivity people with hands-on live experience.
- Custom solutions built around your systems and processes.
- End-to-end application support.
- Ongoing client support & One team of experts for all IT needs.
- Same engineers work with you before and after the sale.
- Documentation of delivered solutions.
- Networking LAN & WAN, Security, Collaboration, Messaging Backup, Archiving, Disaster Recovery/Business Data storages NAS /GRID.

BMS-DCS-PLC and Field Device

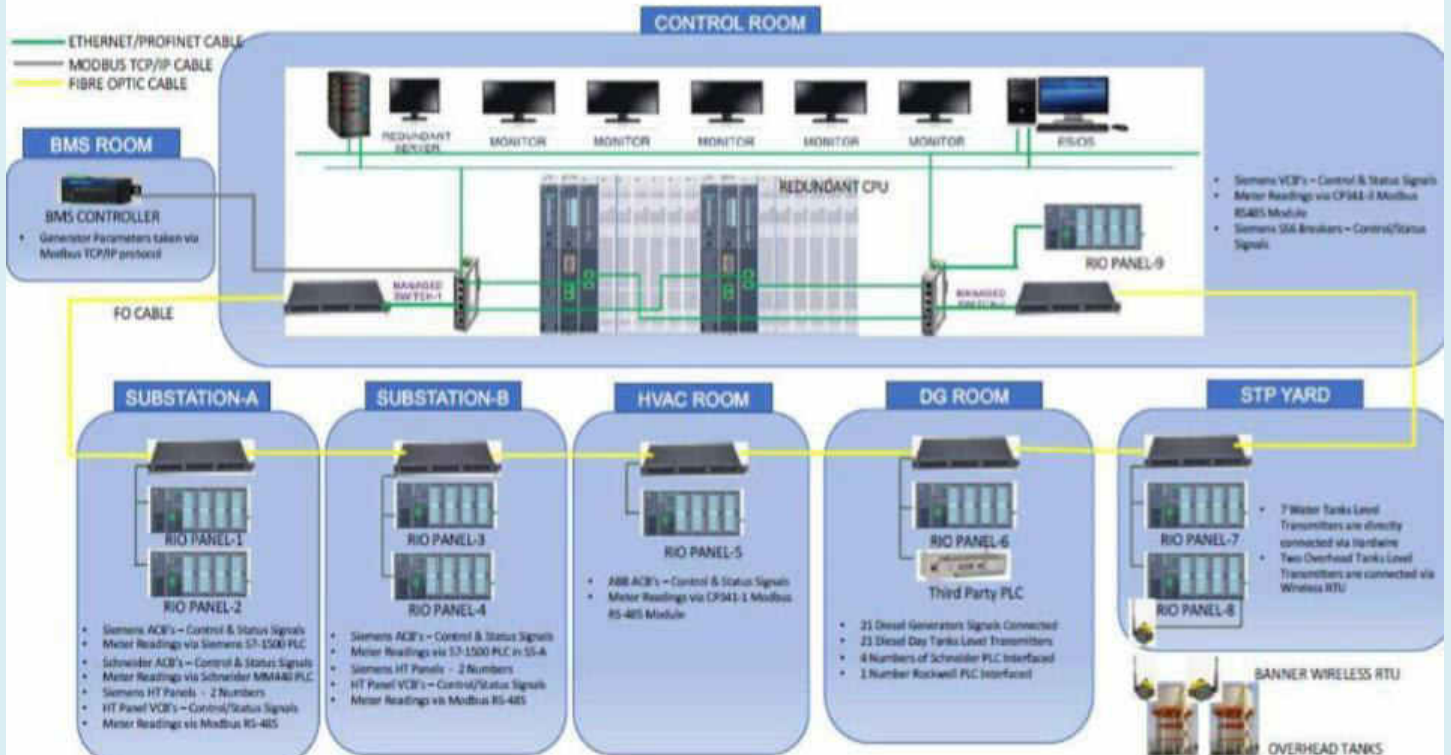

Building Automation and Control Systems

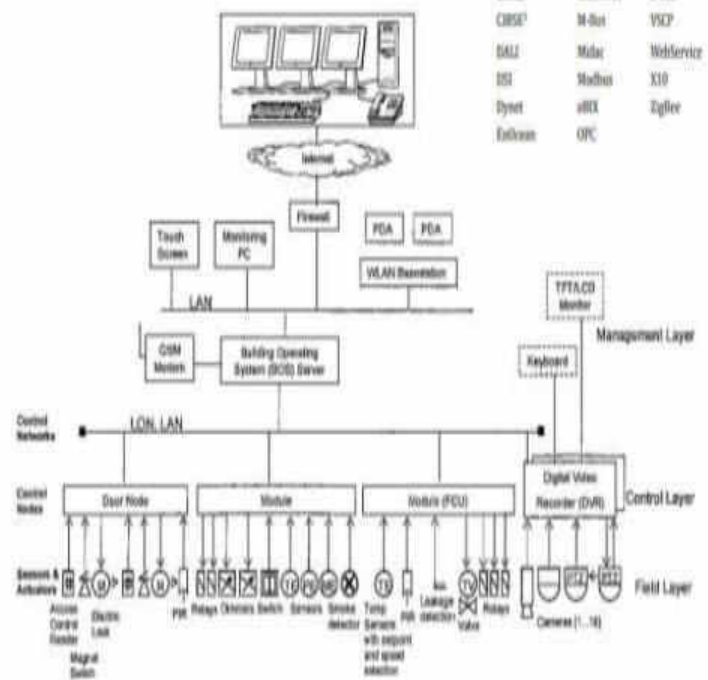
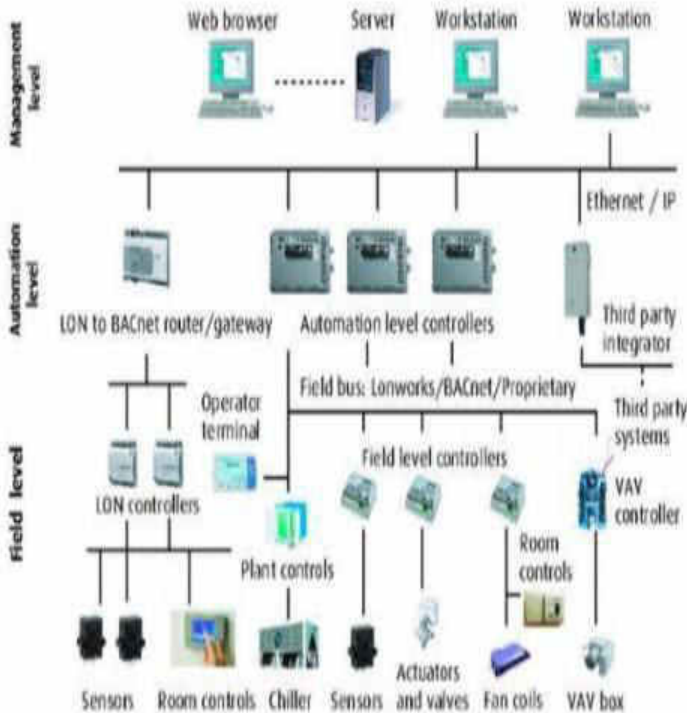

Standards and Protocols

BACnet	XXX	OpenTherm
C-Bus	LonTalk	OpenWebNet
CEBus	LonWorks	S-Bus
CRSE	M-Bus	VSCF
DALI	Molar	WebService
DSI	Modbus	X10
Dynet	vBEX	ZigBee
Echelon	OPC	

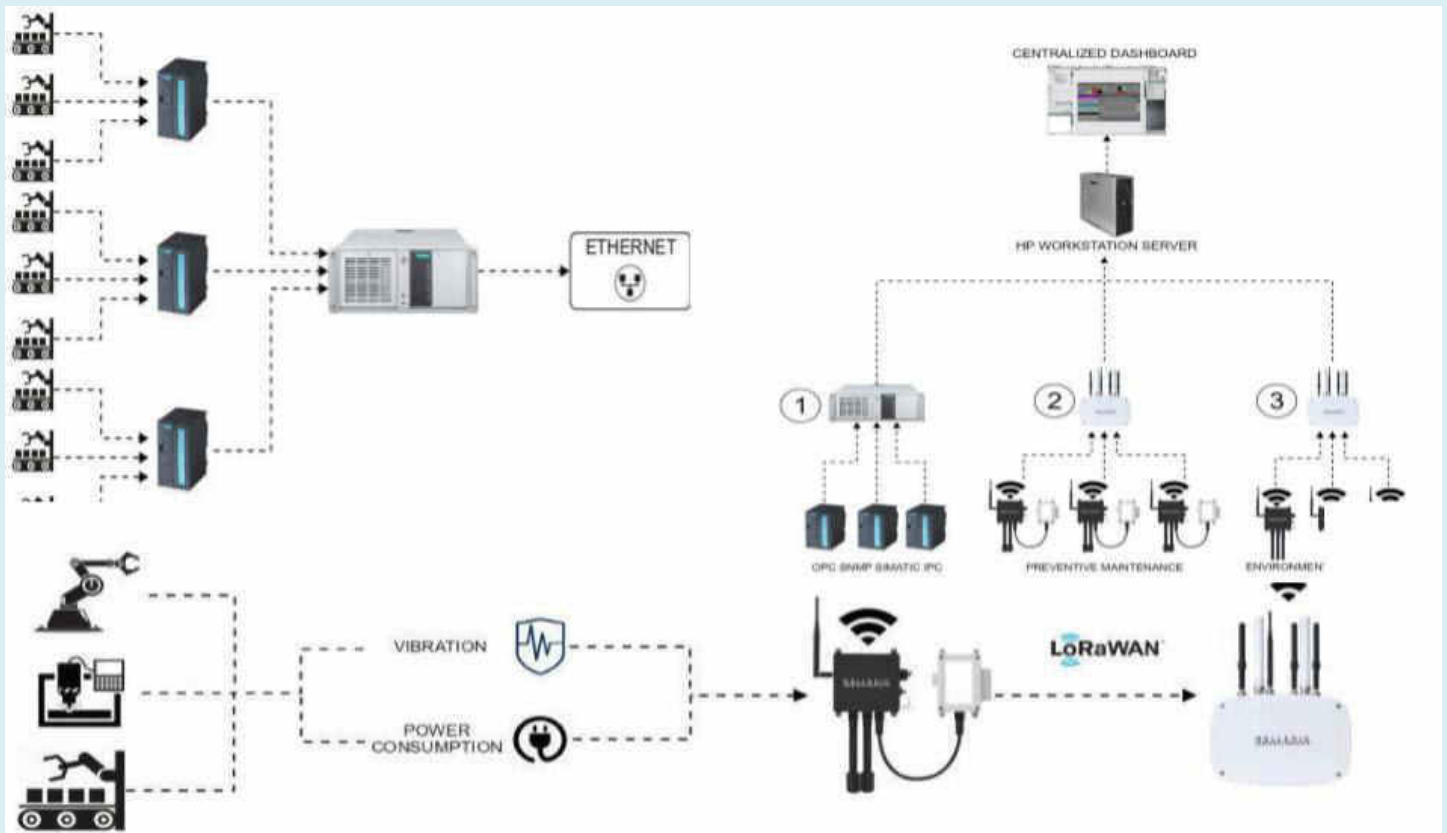
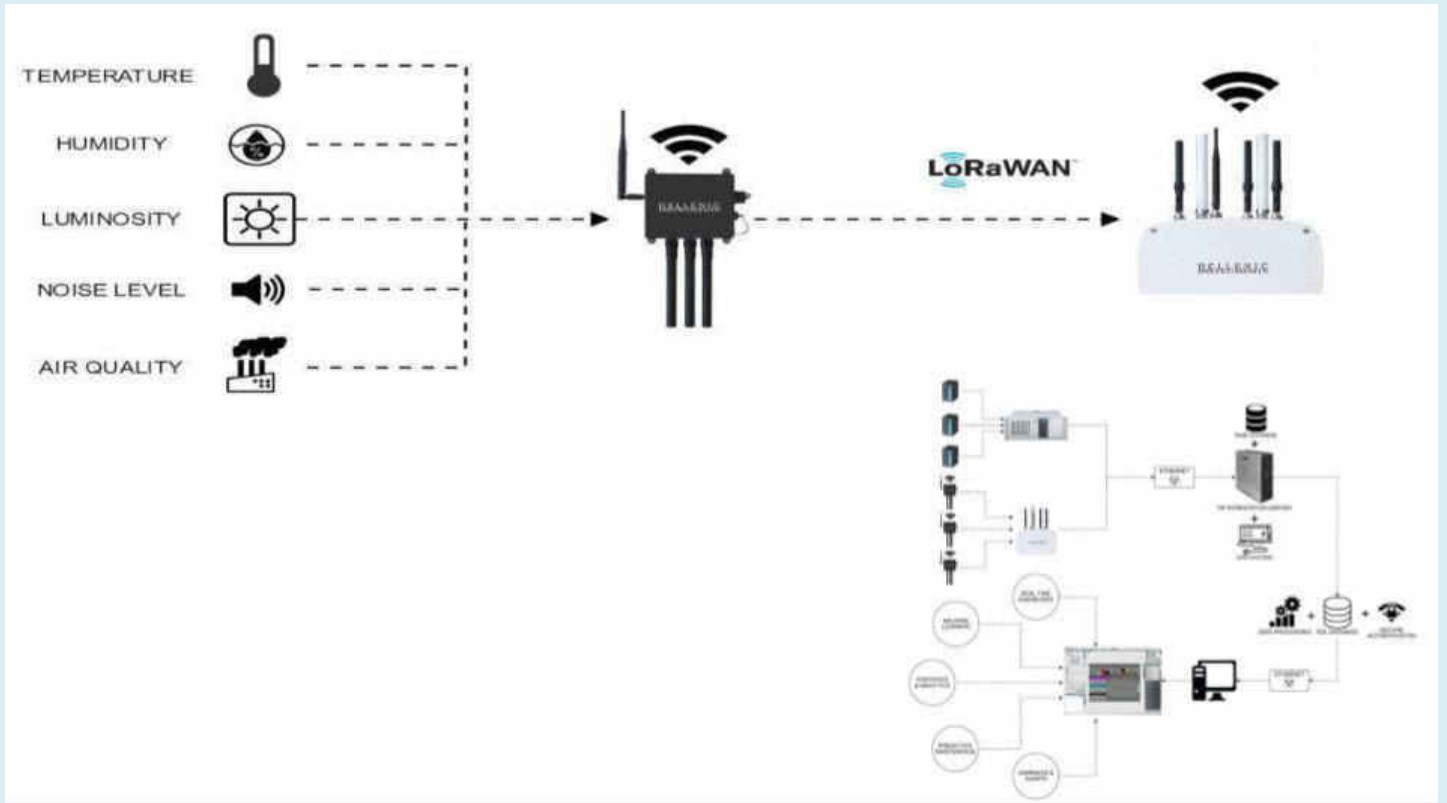

PERIMETER INTRUSION DETECTION SYSTEM (PIDS) SECURE YOUR PREMISES

Perimeter Intrusion Detection System (PIDS) is designed to protect assets within a perimeter by detecting intruders attempting to gain access and blocking such access using the control station. Blue Star R&R offers robust and reliable solutions for accurate detection of such unauthorized entry and protection of assets against these threats. The company's turnkey solutions can detect any unauthorized physical intrusions across the perimeter, assess the situation and track intruders for future actions. Features such as instant alarm generation and control by reporting to central monitoring station make it easier to manage such situations,

PIDS solutions from Link Vue Systems Pvt Ltd are based on microwave technology, Optical Fiber Cable (OFC) or video cameras. These can be fence mounted, buried underground or can be tailored for specific needs, based on customer requirements. Seamless integration of PIDs with other security systems adds one more layer of comfort for the customer. This security system is well suited for military bases, government facilities, oil refineries, Petrochemical plants, power plants, sea ports, airports, VIP residences, Storage yards and so on.

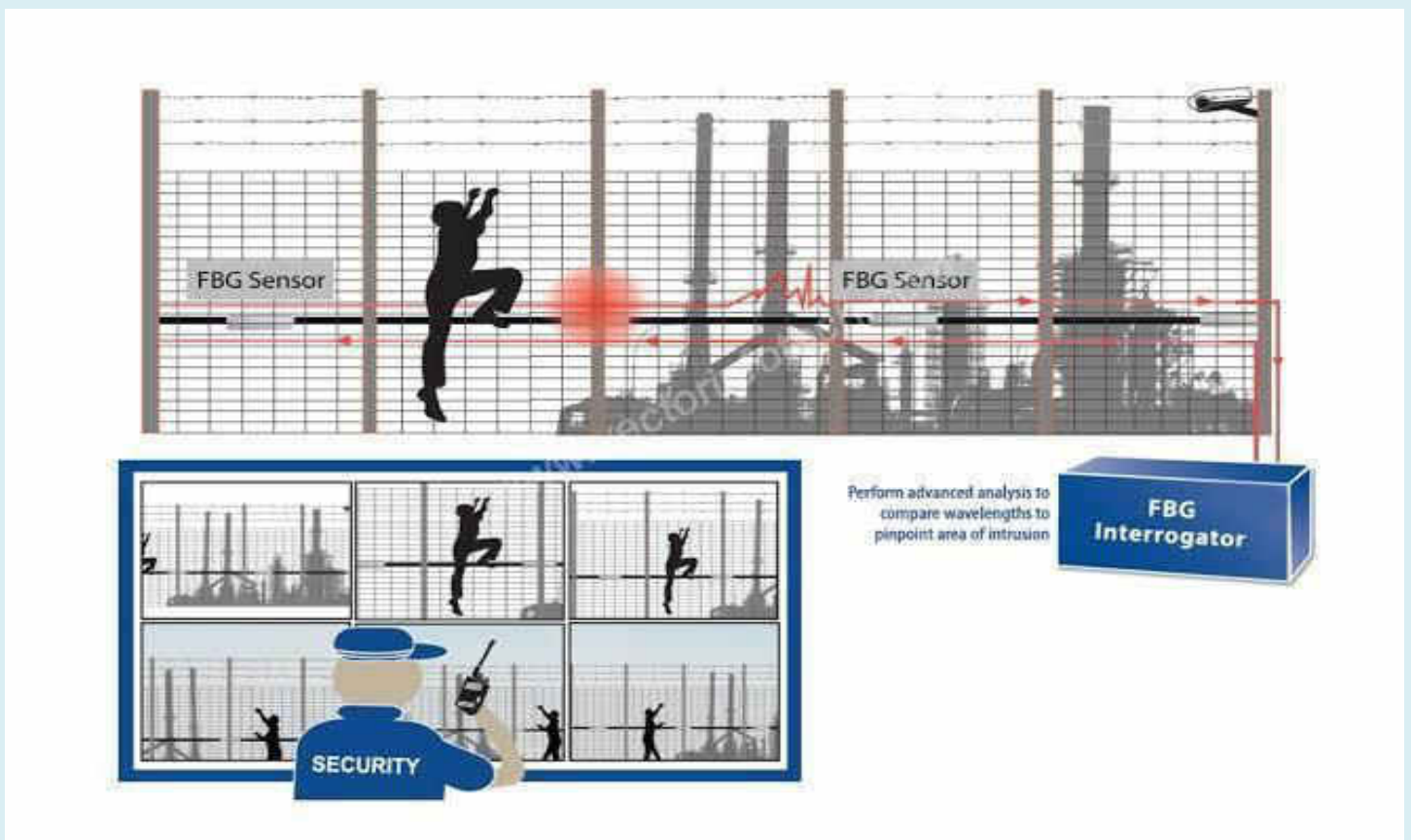

Link Vue System Trading Products Portfolio



www.linkvuesystem.com

Protocon-P7M: Modbus RTU to Modbus TCP/IP



Protocon-P7M

A gateway for your Building Automation solution



Protocon-P7M is a cost effective solutions to connect equipment's with similar communication Protocols and physical Media.

Protocon-P7M is a product from Sunlux that allows users to integrate new and existing Modbus/RTU serial devices to TCP/IP network-based devices. The gateway server allows MODBUS/TCP based Controllers and applications to communicate and interoperate with serial MODBUS RTUs.

Supporting

- RJ45



nodes

- Ethernet port
- 2 x RS485, 1 x RS232 port supports upto 30 nodes.

Protocols supported

- Modbus RTU, Modbus TCP/IP

Mapping data points Supported

- Maximum 500 data points

Applications

- Energy Management with Building Automation Systems
- Integrated metering of HVAC systems and chillers

PRODUCT ORDERING INFORMATION:

MODEL	INTE	ORDER CODE
Protocon-P7M: Modbus RTU to Modbus TCP/IP	1 x RS485	P7M-P1
	2 x RS485	P7M-P2
	2xRS485, 1 x RS232	P7M-P3

TECHNICAL SPECIFICATIONS

Input power	Input Voltage 12V DC, 300 mA, 11W
Environmental	Operating Temperature 0 ° C to 55 ° C (Standard); Humidity 10-90% non-condensing
Processor	CPU Fan less - Cortex Controller Software malfunction protection Watchdog timer
Interfaces	Modbus Slave Choice of 2 - RS485 ports, 1 x RS232. 1 PFC input . RJ45-Ethernet (Modbus TCP/IP)
Communication	1x RS-485 (Screw-terminal) 10/100 Mbps Ethernet with auto-negotiation Serial port supports either 2-wire or 3-wire EIA-485 Baud rates from 2.4 to 115.2 kbps. The baud rate can be set with Web based Configuration Configuration software for data points mappings
Software	
Data points	Maximum 500 data points
Enclosure type	Sheet metal
Weight	225 Grams approximately
Dimension:	90MM (L) X 82MM (H) x 20mm (D)

Note: Mapping configuration Supported per unit ranges from min 1 to max 500 points.

TeleMON™ - Telemetric Monitoring System

Key Features

- ✓ MQTT support over 10/100 fast Ethernet (RJ45) or over built in 3G/4G Modem. Data encrypted with TLS
- ✓ Modbus RTU support on 2 x RS485 ports
- ✓ Modbus TCP support on 10/100 Fast Ethernet (RJ45)
- ✓ Device level security with TPM 2.0, Secure Boot
- ✓ Ruggedized (shock and vibration resistant) for challenging mobile and manufacturing environments
- ✓ Can be powered by 24V DC
- ✓ Provision for onboard data logging with real time stamp with configurable periodicity
- ✓ Configuration available through integrated web server



General Description

TeleMON™ is an industrial grade x86 based gateways. Telemon gateway provides two RS485 serial interface for Modbus RTU protocol, an ethernet interface for Modbus TCP and transfers the data to the cloud using MQTT (SSL/TLS) over 3G or 4G cellular modem or ethernet Interface. TeleMON gateway acquires data from legacy devices and modern sensors analyzes and make the data available at the cloud which would provide a platform for various applications like remote asset management, centralized monitoring etc.

TeleMON is specifically designed to implement data collection systems which operate according to the Internet of Things (IoT) paradigms; It allows bidirectional communication between field equipment and the Cloud software platform. All the data transferred to the cloud are encrypted with Transport Layer Security (TLS). It is possible to configure the MQTT message structure in order to better adapt to the different MQTT Brokers available (Amazon AWS, Mosquito etc.)

Typical Network Diagram



Protocol Specifications

Modbus

- ✓ TCP / RTU Support
- ✓ Holding Register, Input Register, Discrete Inputs, Coils supported
- ✓ Support for function code FC 0x01,0x02,0x03,0x04
- ✓ Serial Baud rate support from 9600 -115200

MQTT

- ✓ TLS 1.2 Certification supported
- ✓ MQTT using OpenSSL
- ✓ Connection and reconnection with configurable QOS level (0,1,2), DUP and Keep Alive Timer supported
- ✓ Publish and Subscribe support with configurable QOS levels (0,1,2)

Ultra Sonic Sensor DASq and GSM Communication

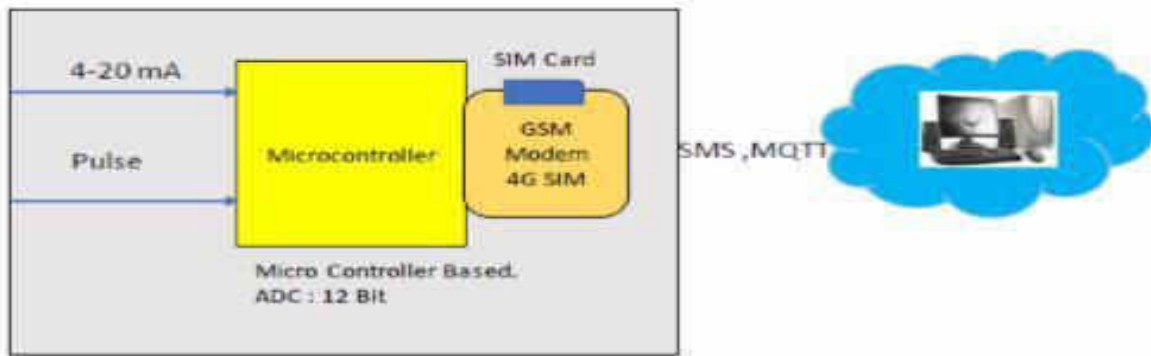

Supply Voltage: 24 VDC
Dimension : 75 x 75x 30 mm
Communication 4G
Protocol : MQTT to MCC room.

Communication Cables



Fiber Optics

- Armored Fiber Optic Cable
- LIU Box
 - Din Rail type
 - Wall Mount
- Patch Cords
 - Ruggedized Patch Cord
 - Armored Patch Cord
- Onsite FO Splicing Service



Serial Device Servers



USB To RS-232/485/422



1-Port RS-232/485/422 to Ethernet



2-Port RS-232/485/422 to Ethernet



Ethernet-Modbus Gateway to 4-Port RS-485/422



8 Port 232/485/422 to Ethernet

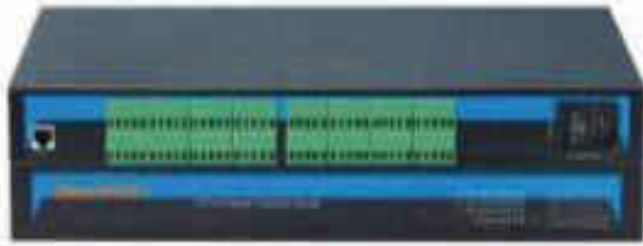

16 Port 232/485/422 to Ethernet

Protocol Converters

Protocol	CAN Open	CC Link	DeviceNet	Ethernet IP	Modbus RTU	Modbus TCP	Profibus	Profinet
CAN open	✓	✓	✓	✓	✓	✓	✓	✓
DeviceNet	✓	✓	✓	✓	✓	✓	✓	✓
Ethernet IP	✓	✓	✓	✓	✓	✓	✓	✓
Modbus RTU	✓	✓	✓	✓	✓	✓	✓	✓
Modbus TCP	✓	✓	✓	✓	✓	✓	✓	✓
Profibus	✓	✓	✓	✓	✓	✓	✓	✓
Profinet	✓	✓	✓	✓	✓	✓	✓	✓
M-Bus	-	-	-	-	✓	-	-	-



CANopen

M-Bus

CC-Link

DeviceNet

Ethernet/IP

Modbus

Ethernet/IP

Profinet

I-IOT Products



GSM Modems



I-IoT Router

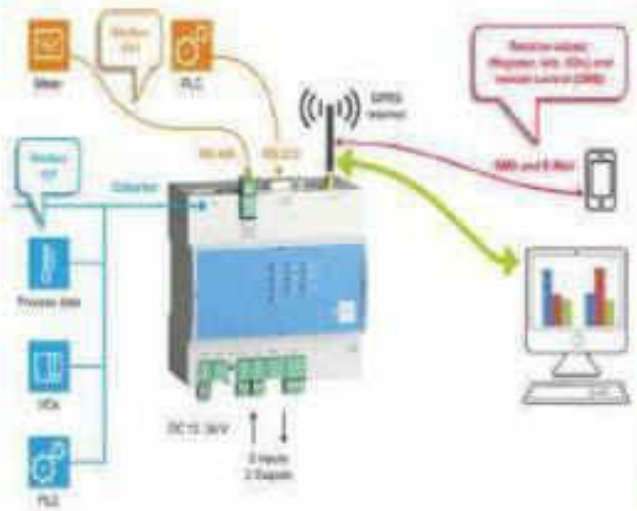

Profibus Products

The **PROFIBUS Tester 5 BC-700-PB** is a powerful diagnostic and troubleshooting tool for testing the cables, measuring the signals and analysing the communication of PROFIBUS networks.

Combination of signal tester, storage oscilloscope, protocol analyzer, master simulator and cable tester functionality in a single diagnostics tool



Profibus HUB



Profibus Terminator



Profibus Repeater



Profibus Cable Stripper



Profibus Connector



Profibus Tester

EKS Engel; Germany	<ul style="list-style-type: none"> • Fiber Optic Media Converter's • DIN rail mounted MINI Patch panels
Elesta GmbH, Switzerland	<ul style="list-style-type: none"> • Relays with Forcibly Guided Contacts
Fint, Norway	<ul style="list-style-type: none"> • Gateway for HART/ FF/ PROFIBUS PA / MODBUS • Wireless HART • Embedded Gateways for HART/ FF/ PROFIBUS PA / MODBUS
Helmholz, Germany	<ul style="list-style-type: none"> • Profibus Connectors with & w/o LED/ PG Port • Profinet RJ45 Connector • Profibus DP-DP Coupler • Profibus 2/4/6 way repeaters • MPI Module • CAN Bus Module • REX 100/ REX 200/REX 250 – Remote Access & Maintenance solutions • Profinet Switches • PN-PN Couplers

Smart Grid & Smart City Solution

Our Product based on Industrial Protocol Development, Application Programming Interface and Software Platforms for Data Acquisition, Data Analysis and Data Monitoring for Numerous Industrial Applications. We always touch to Help Industries to Implement Concepts With Workable Solutions For Efficiency Improvement, Application Monitoring And Effective Control Processes, Systems And Machines. Our Product not only limited with Protocol Gateways, RTUs & SCADA we have recognized Products in the domain of Energy Management System as well as Power Factor Control prepared product list with our strong basket.

- ✓ Power and Energy
- ✓ Environmental Monitoring
- ✓ Equipment Operation and Maintenance

Smart Grid & Smart City Solution



Smart cities depend on a smart grid to ensure reliable energy efficient and quality power Distribution System. Smart Grid is Digitalization of Power Transmission and Distribution System.

Major areas of concern in the power distribution sector are high AT&C loss and poor power distribution reliability. To address these problems accurate measurement, diagnosis and Local remedial action is essential.

The reliability of power is measured in the terms of SAIFI and SAIDI which requires solution based on real time monitoring and Control.

The Feeder Remote Terminal Unit (FRTU) for SAIFA /SAIDI measurement is required at primary substation to our data from status Input devices of breakers or protection relay viz O/C & E/F, CMRs, Multifunction Transducers (MFTs), discrete transducers for analogdata The FRTUs shall be interfaced with the substation equipment, communication equipment, power supply distribution boards;

Along with effective Monitoring, FRTU should also incorporate self-healing and logic for taster restoration of supply even in the absence of control Centre SCADAIntelligent Protocol Gateways in Smart Grid combine the Functionality of Traditional Protocol Converters and IoT Gateways, TheseGateways not only help in interoperability between various equipment supporting difforart Protocols as per Functional requirements.But also support clustering data processing. Processing, network security and Many connectivity Options

RS Consultancy is Pioneer in Engineering and Development of Smart Grid Solutions in Partnership with Global Market Leader in IoT Hardware Advantech Co. Ltd, we Offer indigenized Solutions with.

- Intelligent FRTU
- Smart Grid IoT Gateway
- RSK PGA Smart Utilities

Architecture



Smart Grid Edge Gateway

RSK-PCA Smart Grid Edge Gateway is the Combination of Highly Pugged and Best in Market Hardware from Advantech Taiwan and Our RSK-PCA API, our configuration utility is User Friendly and User can easily configure protocols mapping through interface software for all supported protocols like IEC-104, DNP 3.0, IEC-103, DLMS etc. It also uses IED configuration files to import complex IEC 61850 data structures and same for other intelligent device libraries...

Features and Benefits

Configuration Software (RSK-PCA)	<ul style="list-style-type: none"> Mapping is convenient of protocols from edge gateway Many-to-Many, Many-to-One, One-to-Many protocol translation capability
Programs	<ul style="list-style-type: none"> Logistics for Modbus (RTU/ASCII), IEC 104, IEC 103, IEC 102, IEC 101, IEC 100, IEC 99, IEC 98, IEC 97, IEC 96, IEC 95, IEC 94, IEC 93, IEC 92, IEC 91, IEC 90, IEC 89, IEC 88, IEC 87, IEC 86, IEC 85, IEC 84, IEC 83, IEC 82, IEC 81, IEC 80, IEC 79, IEC 78, IEC 77, IEC 76, IEC 75, IEC 74, IEC 73, IEC 72, IEC 71, IEC 70, IEC 69, IEC 68, IEC 67, IEC 66, IEC 65, IEC 64, IEC 63, IEC 62, IEC 61, IEC 60, IEC 59, IEC 58, IEC 57, IEC 56, IEC 55, IEC 54, IEC 53, IEC 52, IEC 51, IEC 50, IEC 49, IEC 48, IEC 47, IEC 46, IEC 45, IEC 44, IEC 43, IEC 42, IEC 41, IEC 40, IEC 39, IEC 38, IEC 37, IEC 36, IEC 35, IEC 34, IEC 33, IEC 32, IEC 31, IEC 30, IEC 29, IEC 28, IEC 27, IEC 26, IEC 25, IEC 24, IEC 23, IEC 22, IEC 21, IEC 20, IEC 19, IEC 18, IEC 17, IEC 16, IEC 15, IEC 14, IEC 13, IEC 12, IEC 11, IEC 10, IEC 9, IEC 8, IEC 7, IEC 6, IEC 5, IEC 4, IEC 3, IEC 2, IEC 1
Import Configured IED files	<ul style="list-style-type: none"> All IED files are available for convenient mapping to other protocol standards
Modbus TCP/IP Client/Server support	<ul style="list-style-type: none"> Translate Modbus (RTU/ASCII) devices or IEC 104 devices to interface with IEC 103/102/101 devices (one-to-many)
IEC 104 Client/Server support	<ul style="list-style-type: none"> Translate multiple IEC 104 devices or IEC 104 devices to interface with different protocol devices (one-to-many)
IEC 103 Client/Server support	<ul style="list-style-type: none"> Translate multiple IEC 103 devices or IEC 103 devices to interface with IEC 104/102/101 devices (one-to-many)
IEC 102 Client/Server support	<ul style="list-style-type: none"> Translate multiple IEC 102 devices or IEC 102 devices to interface with different protocol devices (one-to-many)

Protocol Support

- IEC 60870
- IEC 60870-5-104
- IEC 60870-5-101
- IEC 60870-5-102
- DNP 3.0
- Modbus RTU/ASCII
- OPC UA
- DLMS
- MQTT

Sample Protocol Connections

- IEC 60870 to Modbus
- Modbus to IEC 104
- Modbus to IEC 103
- IEC 104 to IEC 103
- IEC 60870 to IEC 101
- IEC 60870 to IEC 102
- IEC 103 to IEC 104
- DLMS to IEC 104
- IEC 101 to Modbus

Architecture



Hardware Details

- W602756-800 PDA**
- 1000 counts/sec (40000 CPM) and 1000 CPM, 5min
 - Energy/Time/Temp
 - 2000 counts storage onboard
 - 2 x 20 (2000) stacked read ports
 - 2 x 10 (100) Base 7 Storage ports
 - 1 x Base 7 (2 x 100) (2000)
 - Max Operating temperature: 40-100°



- W602757-800 PDA**
- 1000 counts/sec (40000 CPM)
 - 2000 (2000) Base
 - 1000 counts/sec (40000 CPM) and 1000 CPM, 5min
 - 1 x Base 7 (2000)
 - 2 x 10 (100) Base 7 Storage ports
 - 2 x 10 (100) Base 7 Storage ports
 - 1 x Base 7 (2 x 100) (2000)
 - Max Operating temperature: 40-100°



- W602758-800 PDA**
- 1000 counts/sec (40000 CPM) and 1000 CPM, 5min
 - Energy/Time/Temp (1000)
 - 2000 counts storage onboard
 - 2 x 20 (2000) stacked read ports
 - 2 x 10 (100) Base 7 Storage ports
 - 1 x Base 7 (2 x 100) (2000)
 - Max Operating temperature: 40-100°



Specifications – IEC 103 Client

- Time synchronization
- Time tagged messages
- Time tagged messages with location data
- Addressed to 1
- Time tagged messages with location data
- Addressed to 8
- Configurable Channels
- Client Prot., Data Files, Party, Data 48
- IEC 103 Base
- IEC 103 Address

Specifications – IEC 101 Client/Server

- Multiple Model Support
- Sequence of Events
- Time synchronization
- Single Point Information (SP, SP, TA, S)
- Single Point Information with time tag (SP, SP, TA, S)
- Double Point Information (DP, DP, TA, S)
- Double Point Information with time tag (DP, DP, TA, S)
- Addressed Data, Normalized Data (M, ME, TA, S)
- Addressed Data, Normalized Data with time tag (M, ME, TA, S)
- Addressed Data, Double Data (M, ME, ME, S)
- Addressed Data, Double Data with time tag (M, ME, ME, S)
- Addressed Data, Short Reading point data (M, ME, TC, S)
- Addressed Data, Short Reading point data with time tag (M, ME, TC, S)
- Single Point Information with time tag (SP, SP, TA, S)
- Double Point Information with time tag (DP, DP, TA, S)
- Addressed Data, Normalized Data with time tag (DP, DP, TA, S)
- Addressed Data, Double Data with time tag (DP, DP, TA, S)
- Addressed Data, Short Reading point data with time tag (DP, DP, TA, S)
- Single Command with time tag (C, DC, TA, S)
- Double Command with time tag (C, DC, TA, S)
- Time synchronization command (S, TC, ME, S)
- General data transfer command (C, DC, ME, S)
- Direct to file access (file, address and channel, command or data type command, and gate address, tag and address)
- IP Address
- Port tag
- IEC 103 Address
- Client or Server Mode (S/T)
- Data Message Interval
- Addressed Data Address

Specifications – DNP 3.0 Client/Server

- Time synchronization
- IP Address
- Port tag
- Serial Address
- Channel Address
- Digital Input
- Digital Binary Output
- Analog Input
- Analog Output
- Digital Input
- Analog Input Command
- Digital Output Command
- Time Synchronization Command

Specifications – SNTP/NTP Client

The gateway supports a Simple Network Time Protocol (SNTP/NTP) client service that can synchronize the gateway's time by periodic updates requests to a Coordinated Universal Time (UTC) system.

Specifications – IEC 104 Client/Server

- Multiple Master Support
- Response of Events
- Time synchronization

Process Information (Master and server)	• Single Point Information (M_DP, SA, S)
	• Double Point Information with time tag (M_DP, SA, T)
	• Double Point Information (M_DP, SA, S)
	• Double point information with time tag (M_DP, TA, S)
	• Measurement Status - Normalized Value (M_ME, NA, S)
	• Measurement Value - Normalized Value with time tag (M_ME, NA, T)
	• Measurement Value - Raw Data (M_ME, NS, S)
	• Measurement Value - Raw Data with time tag (M_ME, NS, T)
	• Measurement Value - Status Value with time tag (M_ME, SV, T)
	• Measurement Value - Short Status point value (M_ME, SC, T)
Process Information (Control Element)	• Measurement Value - Short Status point value with time tag (M_ME, SC, T)
	• Single point information with time tag (M_DP, SA, T)
	• Double point information with time tag (M_DP, SA, T)
	• Measurement Value - Normalized Value with time tag (M_ME, NA, T)
	• Measurement Value - Raw Data with time tag (M_ME, NS, T)
	• Measurement Value - Short Status point value with time tag (M_ME, SC, T)
	• Single Command with time tag (C_DP, SA, S)
	• Double Command with time tag (C_DP, TA, S)
	• Clock synchronization command (C_UC, SA, S)
	• Forward synchronization command (C_UC, NA, S)
Please refer to the IEC 104 standard for a complete list of the supported commands.	
Configure Parameters (Client and server)	• IP Address
	• Port No.
	• NMEA Address
	• Class of Transmission (COT)
	• Data Message Format
	• Alternative Object Address

Modbus TCP/IP-Client/Server

The Modbus TCP/IP driver allows multiple independent, concurrent Ethernet connections. The connections may be Clients, servers, or a combination of both Clients and servers.

Configure Parameters (Client and server)	<ul style="list-style-type: none"> • Server Tracking/Registry • Power-On Self Test (POST) Support • Gateway IP Address • Host Name Register
Configure Parameters (Client and server)	<ul style="list-style-type: none"> • Slave Start Register (START) • Gateway Master IP/Start Address • Gateway Master Slave Start Address • Minimum Comment Length
Configure Parameters (Client and server)	<ul style="list-style-type: none"> • Response Timeout • Reply Count • Comment/Char Transfer
Process Data	<ul style="list-style-type: none"> • Full code execution capability for each command • High resolution time available from Modbus TCP/IP Clock through device
Configure Parameters (Client and server)	<ul style="list-style-type: none"> • Each command can be individually enabled or disabled, with only on-off change available

Specifications – DLMS Client

- DLMS/COSEM v2.0 and v2.1

Configure Parameters (Client and server)	• Client Address
	• Server Address
	• Password
	• Physical Serial Address
	• Logical Serial Address

Specifications – IEC 61850 Client

- Supports up to 32 IEDs
- Based on standards from the IEC 61850-5 using Control Types
 - Client with Normal Security
 - Server/Client/Server with Normal Security
 - Client with Enhanced Security
 - Server/Client/Server with Enhanced Security

SCADA supported	IEC 61850-5 (MMS)
Security	<ul style="list-style-type: none"> • Bidirectional Report Control Block (RCB) • Conditional Report Control Block (CRCB)
Server	<ul style="list-style-type: none"> • Client with Normal Security • IED with Normal Security • Client with Enhanced Security • IED with Enhanced Security
Logical Nodes	<ul style="list-style-type: none"> • IEC 61850 Logical Nodes, including Logical
Configure Parameters	<ul style="list-style-type: none"> • MMS Comment Length • Status availability per node
Process Data	<ul style="list-style-type: none"> • Download (DCS) status available

Battery Chargers for Grid TIE and OffGrid with Solar Panels

4KW Battery With Inverter



Solar Panel



Canapoy



Descriptions	Specifications
Battery configuration	51.2V -80 Ah
Capacity of Individual Cell	3.2 V - 80 Ah
Type of Cell	Prismatic
Cell Chemistry	LFP
Nominal Capacity	80 Ah
Nominal Voltage	51.2 V
Voltage Range	40.8 V ~ 58.4V
Total Energy	4096Wh
Configuration	16S 1P
Charging Current	Recommended 0.3C , .5C Maximum (40Amp)
Discharging Current	0.5C standard, 0.95C Max. Discharging(76Amp)
Recommended Discharging Cut-off Voltage	43.2 V
Charging Time	Around 2~3 hours (@0.5C)
Maximum Pulse Discharge Current	350 A (for 2 Sec.)
Cycle Life @ DOD 80%	≥ 2000 Cycles @25°C
Self Discharge rate	< 3% / 30 Days (standard charge 100% SOC & store at 25°C)
Working Temperature Range	-20°C~65°C; humidity ≤ 85% (Discharging) 0°C~50°C; humidity ≤ 85% (Charging)
Storage Temperature Range	-20°C~45°C
Battery Case Material	Metal
Battery Pack Weight	Net Wt. – 40 Kg (Approx)
Battery Pack Dimensions	400x360x250mm (LXWXH)

Descriptions	Specifications
With Packing Dimensions	TBD*
Battery Link	16S
Output Discharging Voltage Nominal	51.2V
Operating Humidity	0% - 90%
Storage Temperature	-20~45°C
Storage Humidity	0% - 90%
Protection Parameters	
Over Charge cut off Voltage	58.4 V
Deep Discharge cut off Voltage	40 V
Short Circuit Protection	Yes
Over Charge Protection	Yes
Cell Balancing	Passive Balancing/Active Balanceing
Communication	As per customer requirement
Degree of Protection	IP 66

Parameter	5KVA/48VDC
-----------	------------

Grid Charger

Grid Voltage Sync Range	170V-260V(±5V)
Grid Frequency Sync Range	50Hz±6%
Charger Peak Efficiency	Higher than 90%
Max Grid Import Power Capacity	Double of Inveter capacity dependent on battery charging current
Max Battery Amp(Charging)	5A to 20A selectable
Self Consumption	Lower than 4%
Recommended DG/GRID Capacity	Double of Inverter Capacity

SOLAR CHARGE CONTROLLER

Controller Type	DSP
Charge Controller Type	MPPT
Charger Topology	BUCK
MAX PV Connection Capacity	5 KWP
No of MPPT Channels	1
Per Channel PV Capacity (Nominal/ Peak)	5 KWP
Max. Open Circuit PV Volts (Voc)	150 V
MPPT Voltage Range	65-130V
Minimum PV Voltage	65 V
Max I/P Amps per channel	104 A

Max Battery Amps during PV charging	Full Capacity in Boost Mode / Current Control in Float Mode as per Battery AH
Max Battery Amps during PV charging	LMLA, VRLA, SMF, Ni-Cd, Lifepo4: Charging Profile can be configured as per the battery requirement
Peak Charging Efficiency	Higher than 94% Upto 98%

Parameter	5KVA/48VDC
-----------	------------

Inverter

Controller Type	DSP
Switching Element	IGBT
Nominal Battery Voltage VDC	48
No of Phases/Connection Type	1Ph , 3 Wire- LNE
Nominal Output Voltage	230V AC $\pm 2\%$
Output Frequency	50Hz $\pm 0.5\%$
Continues Output Power	4000 WP
Out put Amp	17A
Voltage Regulation (Stand Alone)	$\pm 2\%$
Frequency regulation (Stand Alone)	$\pm 0.5\text{Hz}$
THD	THD less than 4%
Out Put Waveform	Pure Sine Wave
Galvanic Isolation	In built Isolation Transformer at Inverter Output
Output Power Factor	0.8 Lagging
Peak Efficiency (Full Load)	Higher than 85%
Overload capacity	125% FOR 60 SEC, 150% FOR 5 SEC / Can be customized
DG Compatibility	Available
Auto Bypass feature	Available
Grid Export Mode	Available, Enable/Disable Options available
Anti Islanding Function	Available, In Compliance with IEC 62116
Compatible IEC standards	IEC -61683:1999- As per MNRE Requirement

Parameter	5KVA/48VDC
Configuration	
Modes Available	3: Hybrid , Grid Export, Stand Alone
Battery Buffer Setting	Selectable from 25%,50%,75%
MPPT Modes	2
Indications	
LED	Grid On, PV On, Grid Charger On,, Load On Grid, Load On Battery , Fault
LCD Display Parameters	
Load Status	Load on,Batt Grid CHRg Grid Sharing
INPUT GRP	Voltage/Current frequency
Inverter GRP	Voltage/current
O/P GRP	Voltage/Current frequency
Solar GRP	PV Vol, Curr PV Power, PV Energy
Battery GRP	Voltage Status Current CH, Current DISC
Dash board	Input KW Output, KW,Solar KW
Faults	Recent 6 fault since last, reset
Alarm	Audible For Fault And Warnings
PROTECTIONS	
PV	Reverse Polarity Indication, optional- Surge Protection
Battery	Over/ Under Voltage, Over Charge , Optional - Reverse Polarity ,Over Temp
Grid	Over/ under Voltage, Over/ Under Frequency, Optional - Surge Protection
Load	Overloads, Short circuit
Circuit Breakers	Grid Input MCB, Battery Input MCB, PV Input MCB, Load Rotary Switch
Temperature	Inverter Over Temperature (optional)

Parameter	5KVA/48VDC
Enclosure	
Degree of Protection	IP 66
Cooling	Forced Fan Cooling
Noise	<50dB
Color	SLATE 7015
Termination	Bottom
Weight	115 KGS
Dimension	W : 345 mm D: 650 mm : H: 740 mm
Environmental	
Temperature Range (Operating)	0 to 50°C
Temperature Range (Storage)	-10 to 50°C
Altitude (max)	1000 m
Humidity	0-95% NON Condensing
Compatible IEC standards	IEC- 60068-2-1, IEC-60068-2-2, IEC-60068-2-14, IEC-60068-2-30- As per MNRE Requirement
Connectivity	RS-232/GSM

Spark gaps are intended to provide galvanic isolation between electrical installation parts where direct connections are not permitted. The galvanic isolation prevents not only electrochemical corrosion but provides also a connection capable of carrying lightning current. For connecting different earthing systems, the aim being to make optimum use of all earthers for lightning protection equipotential bonding.

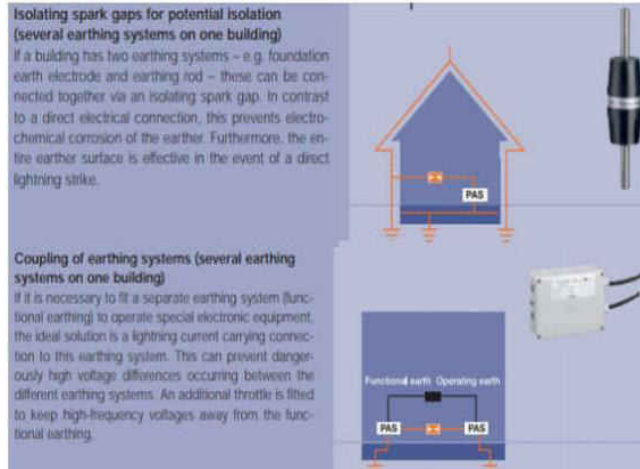

Activate Window
Go to Settings to acti

Surge and Protect

Power Surges and How to Protect Yourself

The Issue

WHAT IS A "POWER SURGE"?
 A power surge, or transient voltage, is a sudden and unwanted increase in voltage that can damage, degrade or destroy the sensitive electronic equipment in your home or business.

CAUSES
 The National Electrical Manufacturers Association (NEMA) estimates that 60-80% of surges are created within a facility, such as when large appliances, like air conditioners, turn on and off. Surges can also originate from the electric utility company during power grid switching. Lastly, the most powerful surges can be caused by lightning.

IMPACT
 A spike in voltage can be harmful to electrical devices in your home if the increase is above the device's intended operating voltage. This excess voltage can cause an arc of electrical current resulting in heat that damages the electrical components. Repeated small-scale surges may slowly damage your electronic equipment and shorten the life of appliances and electronics involved.

The Solutions

POINT-OF-USE SURGE PROTECTION DEVICES
 Protect only the items that are directly plugged into the device from most electrical surges. It does not suppress or arrest a surge but diverts the surge to ground. Use point-of-use surge protectors that have an indicating light and/or audible alarm that alert when it needs replacement.

SERVICE ENTRANCE SURGE PROTECTION DEVICES
 Mounted in or on your main electrical panel or at the base of the electric meter, this device provides protection for your entire electrical system. This device covers components that cannot be connected to a point-of-use device, such as outlets and light switches.

REMINDERS

- ! No surge protection device can handle a direct lightning strike. The best surge protection is to unplug devices from the wall if you suspect a surge might be coming.
- ! Power strips do NOT provide surge protection. Be sure you are relying on the appropriate device for protection.
- ! Power strips and surge suppressors don't provide more power to a location, only more access to the same limited capacity of the circuit into which it is connected.

Activate Window
to Settings to acti

UL SPD Types - Per 1449 4th Edition

Type 1- One port. permanently connected SPDs, except for watt-hour meter socket enclosure, intended for installation between the secondary of the service transformer and the line side of the service equipment overcurrent device, as well as the load side, including watt-hour meter socket enclosures and Molded Case SPDs intended to be installed without an external overcurrent protective device. Type 1 SPDs for use in PV systems can be connected between the PV array and the main service disconnect.

DIN-RAIL SPDs are open Type 1.

Type 2- Permanently connected SPDs intended for installation on the load side of the service equipment overcurrent device, including SPDs located at the branch panel and Molded Case SPDs.

Type 3 - Point of utilization SPDs, installed at a minimum conductor length of 10 meters (30 feet) from the electrical service panel to the point of utilization, for example cord connected, direct plug-in receptacle type and SPDs installed at the utilization equipment being protected. See marking in 80.3. The distance (10 meters) is exclusive of conductors provided with or used to attach SPDs.

Note: type 2 and 3 SPDs were previously known as TVSSs,

Type 4 - Component Assemblies - Component assembly consisting of one or more Type 5 components together with a disconnect (integral or external) or a means of complying with the limited current tests in 44.4.

Type 1, 2, 3 Component Assemblies - Consists of a Type 4 component assembly with internal or external short circuit protection.

Type 5 - Discrete component surge suppressors such as MOVs that may be mounted on a PVVB connected by its leads or provided within an enclosure with mounting means and wiring terminations. V/U_{π} ---nominal system voltage.

A nominal value assigned to designate a system of a given voltage class in accordance with ANSI CB4.1. Typical voltages include 120, 208, 240, 277, 347, 480, 6000 Vac.

V --- Voltage Protection Rating

A rating selected from a list of preferred values as given in Table 63.1 of UL 1449 4th Edition and assigned to each mode of protection. The value of V is determined as the nearest highest value taken from Table 63.1 to the measured limiting voltage determined during the surge test using the combination wave generator at a setting of 6 kV, 3kA. It is also known as let-through voltage.

Guide to Surge Protection Devices (SPDs): selection, application and theory

The following common terminologies, as recognised by BS EN 61643/IEC 62305 are used throughout SPD specifications in order to aid correct selection and are defined as follows:

Nominal Voltage U_0 is the line voltage to Earth a.c. voltage of the mains system (derived from the nominal system voltage) for which the SPD is designed to be the voltage by which the power system is designated - e.g. 230V.

Maximum Continuous Operating Voltage U_c is the maximum RMS voltage that may be continuously applied to the SPD's mode of protection e.g. phase to neutral mode. This is equivalent to the SPD's rated peak voltage.

Temporary Overvoltage U_T is the stated test value of momentary voltage increase or overvoltage that the power SPD must withstand safely for a defined time. Temporary overvoltages, typically lasting up to several seconds, usually

originate from switching operations or wiring faults (for example, sudden load rejection, single phase faults) as well as mains abnormalities such as ferro-resonance effects and harmonics.

Impulse Current I_{imp} is defined by three parameters, a current peak with a charge and a specific energy typically simulated with the 10/350 μ s waveform to represent partial lightning currents. This waveform is used with peak I_{imp} current value stated. for the mains Type 1 SPD Class I test and typically for data telecom SPD Test Category D.

Nominal Discharge Current I_{nspd} is a defined nominal peak current value through the SPD, with an 8/20 μ s current wave shape. This is used for classification of mains SPDs (Class II test) and also for preconditioning of SPDs in Class I and Class II tests.

Maximum Discharge Current I_{max} is the peak current value through the SPD, with an 8/20 μ s wave shape. I_{max} is declared for mains Type 2 SPDs in accordance to the test sequence of the Class II operating duty test. In general, I_{max} is greater than I_{nspd} .

Combined Impulse Test with Open Circuit Voltage U_{oc} is a hybrid 1.2/50 μ s voltage test combined with an 8/20 μ s current. The test is performed using a combination wave generator where its open circuit voltage is defined as U_{oc} , typically 6kV 1.2/50 μ s for the mains Class III test and up to 4kV 12/50 μ s for signal/telecom Test Category C. With an

value of Uoc (3kA 8/20us for the mains Class I test and up to 2kA 8/20us for signal telecom Test Category C). With both voltage and current test waveforms, the combined impulse test is designed to stress all technologies used within SPDS

Voltage Protection Level Up is the key parameter that characterises the performance of the SPD in limiting the transient overvoltage across its terminals. Allow protection level value (also known as let-through voltage) is therefore particularly critical for the effective protection and continued operation of electronic equipment. The peak voltage protection level Up is declared when the SPD is tested with its stated nominal discharge current in for the peak current peak of imp) and is also declared when the SPD is subject to combined impulse test mains Class test for Type 3 SPDS) as well as data telecom Test Categories C and B.

Modes' refer to tie combinations of conductors in which transient overvoltage can occur (e.g. as a result of flashover). Hence transients can exist simultaneously between any combinations of conductors. Electronic systems now pervade almost every aspect of our lives, from the work environment, through filling the car and even shopping at the local supermarket. As a society, we are now heavily reliant on the continuous and efficient running of such systems. The use of computers, electronic process controls and telecommunications has 'increased exponentially' during the last two decades. Not only are there more systems in existence the physical size of the electronics involved has reduced considerably. This reduction in size means less energy is required to damage components.

The operation of electronic systems can be severely affected by lightning activity during thunderstorms or electrical switching events. Both can cause very short duration increases in voltage on mains power and/or data

Communication/signal/telephone lines, with potentially devastating consequences. These increases in voltages are called surges or transient over voltages, all sorts of electronic equipment are at risk such as

- Computers
- Building management systems
- PABX telephone exchanges • CCTV equipment
- Fire and burglar alarms
- Uninterruptible power supplies • programmable logic controllers (PLCS)
- Plant sensors, telemetry and data acquisition equipment
- Weighbridge installations

A lightning surge is severe enough to present a risk of loss of life through fire and/or electric shock hazards through a dangerous flashover. This can occur when the surge voltage exceeds the withstand rating of the cable insulation or equipment. The home environment has also evolved everyday activities rely on electronic equipment. Products such as plasma televisions home theatre equipment alarms. microwaves and washing machines are all vulnerable to voltage surges. Protecting all home electronic equipment is simple with the qualified installation of a surge protection device. Products such as LCD screens. computer networks. data servers and industrial equipment including PLCs provide essential services now crucial to business operational productivity. Protection against the effects of voltage surges in business today is no longer an option, it has become a necessity.

Circuit breakers/fuses are not designed to provide overvoltage protection

Fuses and circuit breakers (aka Overcurrent Protective Devices (OCPDs) are designed to protect your home business equipment and possibly even your life from an event such as a short circuit or overload,

The Surge Protective Device (hereafter referred to as an SPD) is specifically designed to protect equipment from events such as extremely short duration high voltage spikes. These voltage spikes or transients are everyday occurrences and can be caused by anything from switching on a lamp to lightning storm most spikes are of low energy. Some spikes



Monoblock Single-Pole SPD

SPT25-XXX/1(S)

Class I • Class II • Type 1 • Type 2

Location of Use: Main Distribution Boards
Network Systems: TN-S, TN-C, TT
Mode of Protection: L-PE / N-PE
Surge Ratings: $I_{imp} = 25 \text{ kA} (10/350 \mu\text{s})$
 $I_n = 25 \text{ kA} (8/20 \mu\text{s})$
IEC/EN Category: Class I+II / Type 1+2
Protective Elements: High Energy MOV
Housing: Monoblock Design
Compliance: IEC 61643-11:2011
EN 61643-11:2012



Monoblock Multi-Pole SPD

SPT25-XXX/2(S)

Class I • Class II • Type 1 • Type 2

Location of Use: Main Distribution Boards
Network Systems: TN-S
Mode of Protection: L-PE / L'PE, N-PE / N'PE
Surge Ratings: $I_{imp} = 25 \text{ kA} (10/350 \mu\text{s})$
 $I_n = 25 \text{ kA} (8/20 \mu\text{s})$
IEC/EN Category: Class I+II / Type 1+2
Protective Elements: High Energy MOV
Housing: Monoblock Design
Compliance: IEC 61643-11:2011
EN 61643-11:2012



Monoblock Multi-Pole SPD

SPT25-XXX/3(S)

Class I • Class II • Type 1 • Type 2

Location of Use: Main Distribution Boards
Network Systems: TN-C
Mode of Protection: L-PE / L'PE
Surge Ratings: $I_{imp} = 25 \text{ kA} (10/350 \mu\text{s})$
 $I_n = 25 \text{ kA} (8/20 \mu\text{s})$
IEC/EN Category: Class I+II / Type 1+2
Protective Elements: High Energy MOV
Housing: Monoblock Design
Compliance: IEC 61643-11:2011
EN 61643-11:2012



Monoblock Multi-Pole SPD

SPT25-XXX/4(S)

Class I • Class II • Type 1 • Type 2

- Location of Use: Main Distribution Boards
- Network Systems: TN-S
- Mode of Protection: L-PE / L'PE, NPE / N'PE
- Surge Ratings: $I_{imp} = 25 \text{ kA} (10/350 \mu\text{s})$
 $I_n = 25 \text{ kA} (8/20 \mu\text{s})$
- IEC/EN Category: Class I+II / Type 1+2
- Protective Elements: High Energy MOV
- Housing: Monoblock Design
- Compliance: IEC 61643-11:2011
EN 61643-11:2012



Monoblock Multi-Pole SPD

SPT25-XXX/1(S)+1

Class I • Class II • Type 1 • Type 2

- Location of Use: Main Distribution Boards
- Network Systems: TT, TN-S
- Mode of Protection: L-N / L'N, N-PE
- Surge Ratings: $I_{imp} = 25 \text{ kA} / 50 \text{ kA} (10/350 \mu\text{s})$
 $I_n = 25 \text{ kA} / 50 \text{ kA} (8/20 \mu\text{s})$
- IEC/EN Category: Class I+II / Type 1+2
- Protective Elements: High Energy MOV and GDT
- Housing: Monoblock Design
- Compliance: IEC 61643-11:2011
EN 61643-11:2012



Monoblock Multi-Pole SPD

SPT25-XXX/3(S)+1

Class I • Class II • Type 1 • Type 2

- Location of Use: Main Distribution Boards
- Network Systems: TT, TN-S
- Mode of Protection: L-N / L'N, N-PE
- Surge Ratings: $I_{imp} = 25 \text{ kA} / 100 \text{ kA} (10/350 \mu\text{s})$
 $I_n = 25 \text{ kA} / 100 \text{ kA} (8/20 \mu\text{s})$
- IEC/EN Category: Class I+II / Type 1+2
- Protective Elements: High Energy MOV and GDT
- Housing: Monoblock Design
- Compliance: IEC 61643-11:2011
EN 61643-11:2012



New Modular Single Pole & Multi-pole Surge Protective Devices

New Housing Design Features

- Contemporary design
- Low residual protection level
- Lifetime indicators
- Redesigned thermal disconnection
- Patented protection technologies
- No external back-up fuse required up to 315 A
- Vibration and shock withstand capability
- Space-saving design
- Easy replacement
- Patented module locking mechanism
- Meets IEC/EN and UL 1449 4th Edition

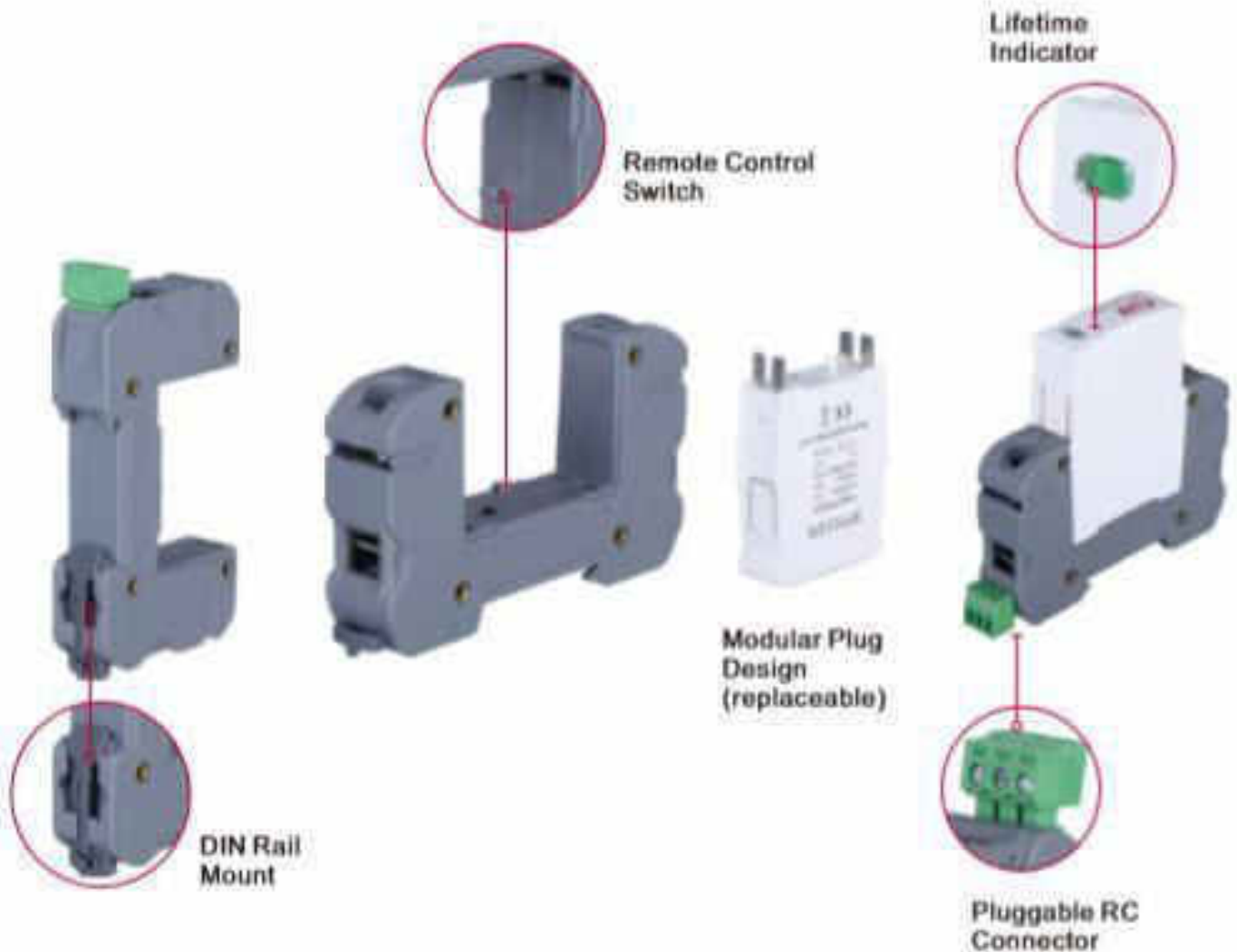

Type 1/Type 2 SPD



SPT12.5-XXX/1(S)



SPT12.5-XXX/2(S)



SPT12.5-XXX/3(S)



SPT12.5-XXX/4(S)



SPT12.5-XXX/1(S)+1



SPT12.5-XXX/3(S)+1



SPT12.5-PVXXX-(S)

Type 2 SPD



SPT40-XXX/1(S)



SPT40-XXX/2(S)



SPT40-XXX/3(S)



SPT40-XXX/4(S)



SPT40-XXX/1(S)+1



SPT40-XXX/3(S)+1



SPT40-PVXXX-(S)

Pluggable Multi-Pole SPD for Photovoltaic Systems

SPT40-PVXXX-(S)

Class II • Type 2 • Type 1CA

Location of Use: String box, Inverter

Mode of Protection: (DC+)-PE, (DC-)-PE, (DC+)-(DC-)

Surge Ratings: $I_n = 20kA$ (B/20 μs)

$I_{max} =$ up to 40kA (B/20 μs)

IEC/EN/UL Category: Class II/Type 2/Type 1CA

Protective Elements: High Energy MOV

Housing: Pluggable Design

Compliance: IEC 61643-31:2018

EN 50539-11:2013+A1:2014

UL 1449-4th Edition



In-line SPD for Coaxial & RF Systems

SPT CP BNC

C1 • C2 • C3

IEC/EN Category:	C1/C2/C3
Protection:	Impedance Matched
Maximum Operating:	
Voltage:	70, 180, 280 V
Maximum Peak Power:	40, 125, 300 W
Frequency Range:	DC – 2.6 GHz
Surge Discharge Ratings:	I_n : 10 kA, I_{max} : 20 kA
Impedance:	50 Ω
Insertion Loss:	< 0.4 dB
Return Loss:	> 20 dB
Termination:	BNC Type (F-F, M-F)
Housing:	In-line Installation, Shielded Enclosure
Compliance:	IEC/EN 61643-21



SPTs for Telecommunication and Data Networks

The "PoE Surge Protector" permits the use of Power over Ethernet with nominal currents of up to 1 A. It can be snapped directly onto the hot rail and uses it to create the necessary equipotential bonding. Alternatively, terminal protection using a separately connectable

- Support for Power over Ethernet • up to 1 A (PoE) according to IEEE 802.3at)
- CAT 6A in the channel according to ANSI/TIA/EIA-568
- For installation in conformity with the lightning protection zone concept at the boundaries from 0-2 and higher

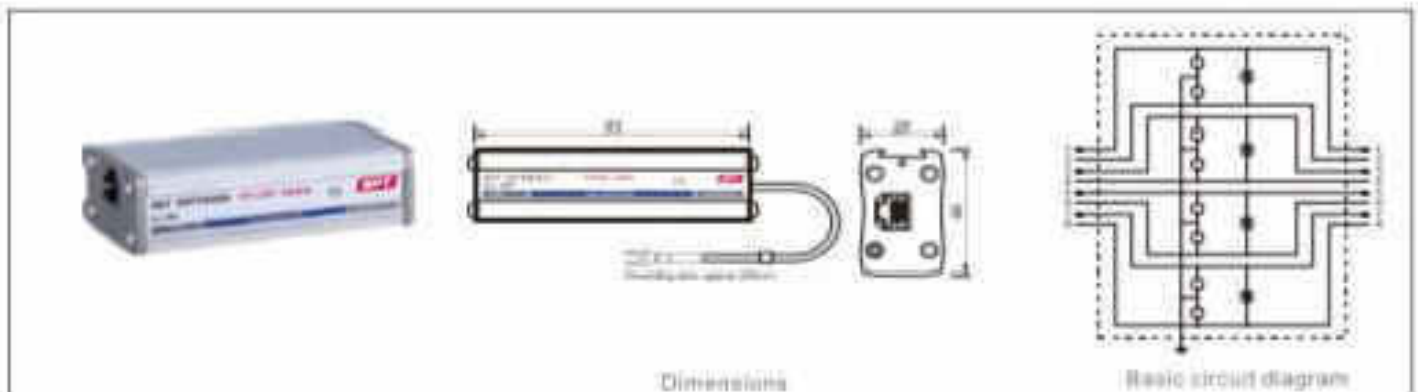

Modular SPD for Single Pair

SPT-DC Series

D1 • C1 • C2 • C3

IEC/EN Category:	D1/C1/C2/C3
Mode of Protection:	Longitudinal, Transverse
Coarse Protection:	3 Terminal GDT
Voltages:	5, 12, 15, 24, 30*, 48, 60, 110 VDC
Frequency Range:	30 MHz
Surge Discharge Ratings:	I_c : 10 kA, I_{max} : 20 kA, I_{max} : 2.5 kA
Series Load Current:	1 A
Enclosure:	DIN 43880 2/3 TE, DIN Rail Mount
Terminals:	Stranded to 4 mm ²
Housing:	Modular Design
Compliance:	IEC/EN 61643-21 UL 497B 4th Edition



LED Light for Outdoor Conditions

SHV LED GLOWING THE FUTURE

LED FLOOD LIGHTS

Designed to deliver high efficiency and excellent weathering, LED Flood Lights feature single, double, triple, and quad lighting for a variety of outdoor applications. They are available in a variety of sizes, colors, and beam angles. They are also available in a variety of mounting options.

Details	SHV-FL-100	SHV-FL-150	SHV-FL-200
Input Power	30W	45W	60W
Input Voltage	AC100-240V/50/60Hz		
Color Temperature	3000K-6500K		
CRI	More than 80		
Beam Angle	150 deg		
Lumens	3400	5100	6800
Operating Temperature	-20 deg to 60 deg centigrade		

Uses : Handings, Shopping Centers, Showrooms, Mall, Corridor.

LED PANEL LIGHTS

LED panel lights are the most popular lighting option for a variety of indoor applications. They are available in a variety of sizes, colors, and beam angles. They are also available in a variety of mounting options.

Details	SHV-PL-100	SHV-PL-150	SHV-PL-200
Input Power	30W	45W	60W
Input Voltage	AC100-240V/50/60Hz		
Color Temperature	3000K-6500K		
CRI	More than 80		
Beam Angle	150 deg		
Lumens	3400	5100	6800
Operating Temperature	-20 deg to 60 deg centigrade		

Uses : Residential, Showrooms, Offices, Mall.

SHV LED GLOWING THE FUTURE

LED TUBE LIGHTS - T5 & T8

LED tube lights are a popular choice for indoor lighting applications. They are available in a variety of sizes, colors, and beam angles. They are also available in a variety of mounting options.

Details	SHV-T505	SHV-T508	SHV-T510	SHV-T808	SHV-T810
Input Power	5W	8W	10W	8W	10W
Input Voltage	AC100-240V/50/60Hz				
Size (Ft.)	1	2	4	2	4
Color Temperature	3000K-6500K				
CRI	More than 80				
Beam Angle	120 deg				
Lumens	510	1020	1800	1000	2000
Operating Temperature	-20 deg to 60 deg centigrade				

Uses : Residential, Showrooms, Offices, Mall.

LED STREET LIGHTS

LED street lights are a popular choice for outdoor lighting applications. They are available in a variety of sizes, colors, and beam angles. They are also available in a variety of mounting options.

Details	SHV-SL-100	SHV-SL-150	SHV-SL-200	SHV-SL-250	SHV-SL-300
Input Power	30W	45W	60W	75W	90W
Input Voltage	AC100-240V/50/60Hz				
Color Temperature	3000K-6500K				
CRI	More than 80				
Beam Angle	120 deg				
Lumens	3400	5100	6800	8500	10200
Operating Temperature	-20 deg to 60 deg centigrade				

Uses : Street Lighting, Corridor, Mall.

SHV LED GLOWING THE FUTURE

LED BULBS

Every Light fixture benefits from a well-chosen light bulb. Improvements over the years have made LED light bulbs a very good choice. LED bulbs offer both practical and aesthetic advantages over other light sources. They are energy efficient, long lived, and give clear, consistent light.

Details	SHV-B-30	SHV-B-40	SHV-B-50	SHV-B-60	SHV-B-70
Input Power	3W	4W	5W	6W	7W
Input Voltage	AC100-240V/50/60Hz				
Color Temperature	3000K-6500K				
CRI	More than 80				
Beam Angle	120 deg				
Lumens	40	280	410	630	780
Operating Temperature	-20 deg to 60 deg centigrade				

Uses : Residential, Showrooms, Offices, Mall.

Solar Street Lights

Solar street lights are a popular choice for outdoor lighting applications. They are available in a variety of sizes, colors, and beam angles. They are also available in a variety of mounting options.

Details	SHV-SL-100	SHV-SL-150	SHV-SL-200	SHV-SL-250	SHV-SL-300
LED Light Wattage	6	9	12	18	24
Solar Panel (W)	40	30	20	15	10
Battery (Ah)	40	40	20	15	10
Q1 Panel (W)	6	9	12	18	24
Autonomy (Days)	2	2	2	2	2
Warranty (Years)	2	2	2	2	2

Uses : Residential, Showrooms, Offices, Mall.

SHV LED GLOWING THE FUTURE

AN ISO CERTIFIED COMPANY

Save Energy Save Earth

Regd. Office:
SHV LED ENTERPRISES
20/253, VADAKKUNTHALA,
COCHIN-682015
Kerala, IN
TOLL FREE: 1800-425-1800
Shiv TV Channel: 11 P

Email: shvled.com@gmail.com
Website: www.shvled.com
Contact: +91-9520031715
+91-988227801
+91-7340718915
Land Line Number: 0120-4182739

Earthing is Nothing less than Engineering

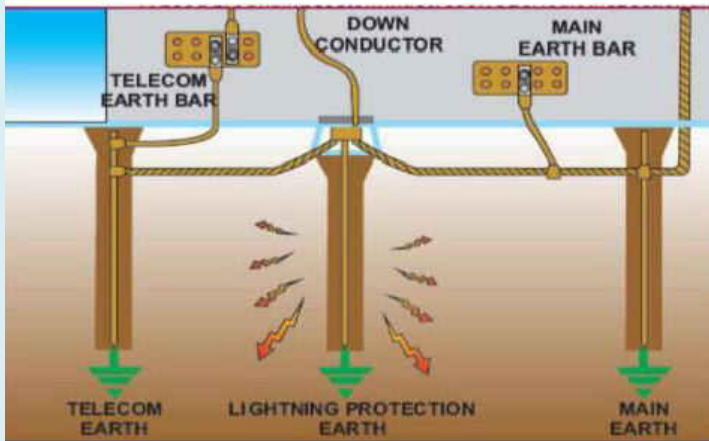

Maintenance Free Earthing installation as per IS3043(2018)

General Arrangements for Earth System

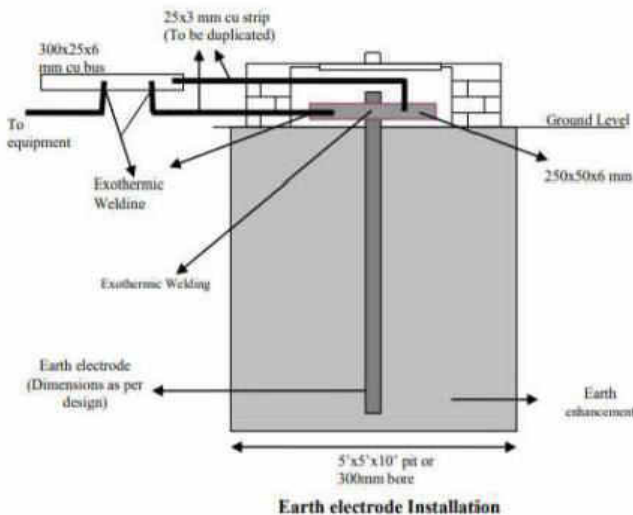

S.N.	Installations/ Current Capacity	IR Value Required	Soil Type/ Resistivity	Earth System
1.	House hold earthing/ 3kA	8 ohm	Normal Soil/ upto 50 ohm-mtr	Single Electrode
			Sandy Soil/ between 50 to 2000 ohm-mtr	Single Electrode
			Rocky Soil/ More than 2000 ohm-mtr	Multiple Electrodes
2.	Commercial premises Office buildings/ 5kA	2 ohm	Normal Soil/ upto 50 ohm-mtr	Single Electrode
			Sandy Soil/ upto 2000 ohm-mtr	Multiple Electrodes
			Rocky Soil/ More than 2000 ohm-mtr	Multiple Electrodes
3.	Transformers, substation earthing, LT line equipment/ 15kA	1 - 2 ohm	Normal Soil/ upto 50 ohm-mtr	Single Electrode
			Sandy Soil/ upto 2000 ohm-mtr	Multiple Electrodes
			Rocky Soil/ More than 2000 ohm-mtr	Multiple Electrodes
4.	Transformers, substation earthing, HT line equipment/ 40kA	less than 1 ohm	Normal Soil/ upto 50 ohm-mtr	Single Electrode
			Sandy Soil/ upto 2000 ohm-mtr	Multiple Electrodes
			Rocky Soil/ More than 2000 ohm-mtr	Multiple Electrodes
5.	Lightning arresters, extra high current applications etc./ 50kA	less than 1 ohm	Normal Soil/ upto 50 ohm-mtr	Single Electrode
			Sandy Soil/ upto 2000 ohm-mtr	Multiple Electrodes
			Rocky Soil/ More than 2000 ohm-mtr	Multiple Electrodes
6.	PRS, UTS, RTUs, FOIS, COIS, ATMs and data processing centre etc./5KA	less than 0.5 ohm	Normal Soil/ upto 50 ohm-mtr	Single Electrode
			Sandy Soil/ upto 2000 ohm-mtr	Multiple Electrodes
			Rocky Soil/ More than 2000 ohm-mtr	Multiple Electrodes

Maintenance Free Earthing Value Calculation & Costing Per PIT

Thumb Rule for Calculate Number of Earthing Rod

The approximate earth resistance of the Rod/Pipe electrodes can be calculated by:

Earth Resistance of the Rod/Pipe electrodes:

$$R = K \times \rho / L$$

Where:

ρ = Resistivity of earth in Ohm-Meter
 L = Length of the electrode in Meter.
 d = Diameter of the electrode in Meter.
 $K = 0.75$ if $25 < L/d < 100$,
 $K = 1$ if $100 < L/d < 600$
 $K = 1.2$ if $600 < L/d < 300$

Number of Electrode if find out by Equation of $R(d) = (1.5/N) \times R$

Where:

$R(d)$ = Desired earth resistance
 R = Resistance of single electrode
 N = No. of electrodes installed in parallel at a distance of 3 to 4 Meter interval.

Example: Calculate Earthing Pipe Resistance and Number of Electrode for getting Earthing Resistance of 1 Ω . Soil Resistivity of $\rho=40$, Length=2.5 Meter, Diameter of Pipe = 38 mm.

Here:

$$L/d = 2.5/0.038=65.78 \text{ so } K = 0.75$$

- The Earth Resistance of the Pipe electrodes $R = K \times \rho / L = 0.75 \times 65.78 = 12 \Omega$
- One electrode the earth resistance is 12 Ω .
- To get Earth resistance of 1 Ω : the total Number of electrodes required = $(1.5 \times 12) / 1 = 18$ No

- BOQ Per Earthing PIT
- 17.2mm Copper Bonded 3 Mtr ROD=1
- Earth Enhance Compound(Value 0.012 Ohm) Qty -30 KG
- Earthing Clamp Connector for Connecting FLAT STRIP/Conductor - 01
- Earthing Strip /Conductor as per Equipment Load /Fault Current -10 Mtrs
- High Quality Industrial Plastic PIT Cover

**KORS BRAND
 ADVANCED SOLUTIONS FOR ELECTRICAL SAFETY
 EARTHING LIGHTNING ARRESTERSURGE PROTECTION**



Conventional LA as per standard
 IS 2309, IEC 62305, NBC 2016



Copper Bonded Rod
 Inbuilt Customized
 Connector



Lattice Copper Mat



Copper Plate



Copper Flexible Jumper



Copper Bonded Rod
 Zig Pattern



Copper Bonded Rod
 With or Without Clamp



Cast Iron Pit Cover



FRP Pit Cover



PVC Pit Covers



PVC Pit Covers



PVC Pit Covers



HDPE FRP Pit Cover



DMC and PVC Insulator



Receptacle



Nut Bolt and Bimetallic Washer



Earthing Cable



Conventional Insulator



Test Link



Conduit Pipe



Mast

Graphite Mould



Mould Handle Clamp



Exothermic Weld Powder & Steel Metal Desk



Gloves



Flint Gun



Brush Soft & Hard



Flame Torch



File Card

Slag Removal Tool



**YOUR TRUST
OUR PROTECTION**

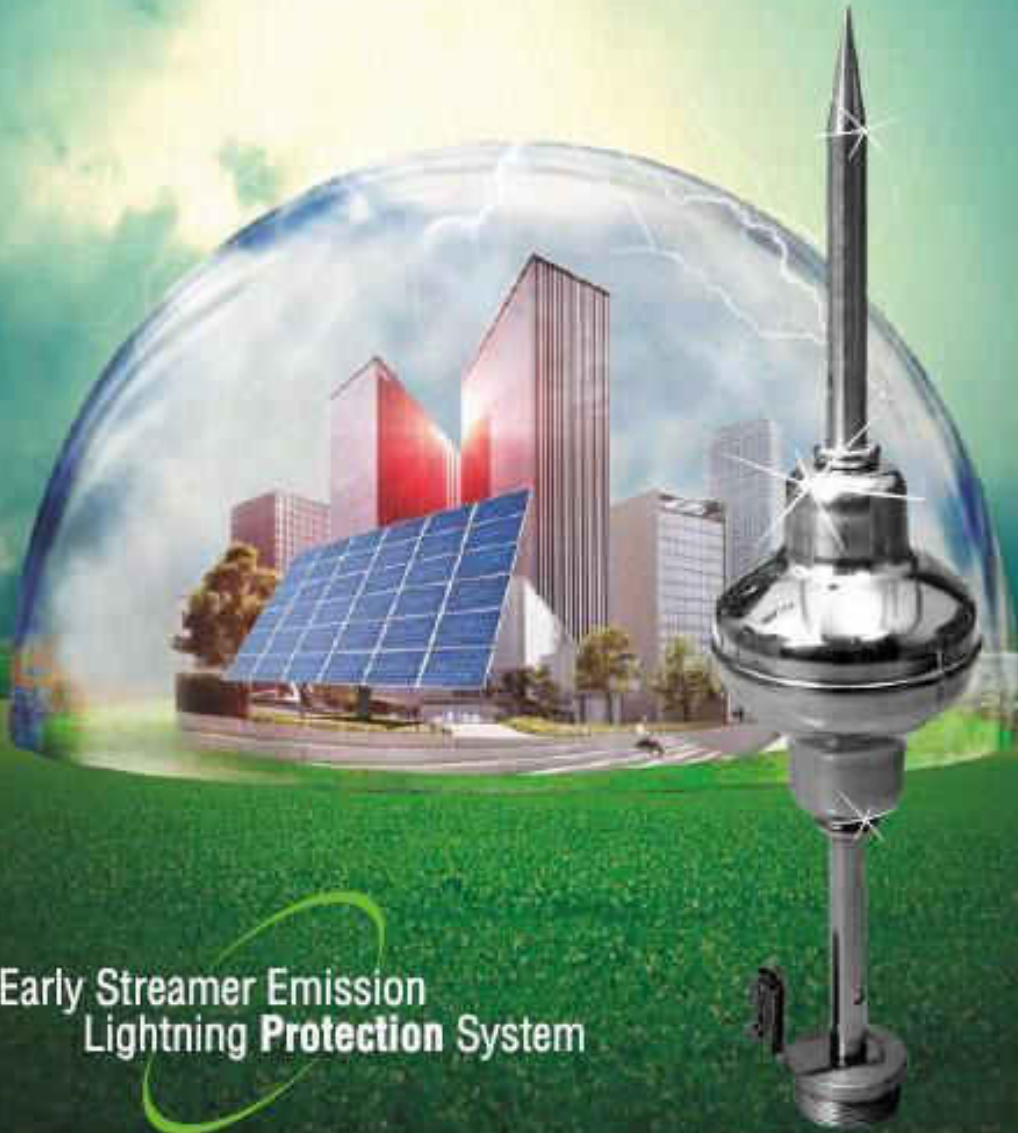

PARATONEX LIGHTNING PROTECTION SYSTEMS

PARATONEX a pioneer in the design and manufacture of Lightning Rods, Surge Protection Device and Grounding Products. PARATONEX product ranges are of External protection (ESE Lightning rod and Faradisation), Internal protection (Surge protection device) and grounding/earthing products. With years of experience in the sector of lightning protection systems and after thoroughly studying the problems associated with lightning overtime, our company was established with modern lightning protection technologies. PARATONEX Lightning Protection products are available at the affordable cost and at the same time it offers higher quality than most other companies.



5 POINT PLAN OF PROTECTION



RESEARCH & DEVELOPMENT

As one of the leading companies in the field of lightning protection, PARATONEX has invested heavily in field and laboratory testing as part of its ongoing commitment to research and development.

Throughout the product development of the PARATONEX, the proto-type models were subjected to intense testing under high voltage conditions. Following further refinements, the PARATONEX ESE air terminals were subjected to final testing by an independently accredited test laboratory which completed testing in full compliance with the French National standard NF C 17-102: 2011. The final testing of PARATONEX ESE terminals showed effective performance as defined in the standard.

PARATONEX 5 POINT PLAN OF PROTECTION

PARATONEX is trusted world leader for providing high quality direct strike lightning protection, surge protection and grounding solutions. By recognizing the importance of an integrated lightning protection strategy, PARATONEX has incorporated several major concepts into a Five point plan of protection:

1. Capture the direct lightning strike
2. Dissipate energy into the grounding system
3. Creation of a bonded earthing system
4. Protection of incoming AC power feeders
5. Protection of signal, data, telecommunication & communication lines

PARATONEX operates in every region of the world and supports the global market with an extensive distribution network, helping to ensure that PARATONEX products are available for any project, regardless of size or location.

Freedom Wire Connectors and Industrial Plug and Socket for High Power Equipment's

We are offering Advance and Allegiance Type Plug and Socket for Power ,Data and Communication Port this is very important and useful for Office,Conference Hall ,Data Centers ,Large Customer Handling Places like Hotels, Shopping Mall , Hospitals , Railway Station, Airports and other public places .

Indoor and out door purpose from 5Amps up to Max 400Amps Plug and Socket.

We are also offering Connectors for Power Cables wire Cable 1.5Sqmm to 6.00Sqmm Cable to Cable Free ,hanging, and Fixed Type Connections

Application scene graph



bank front desk



hospital

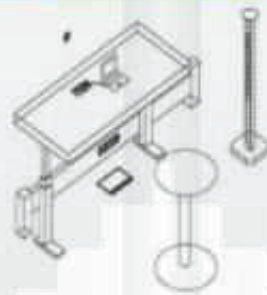

office liftable table



raised floor

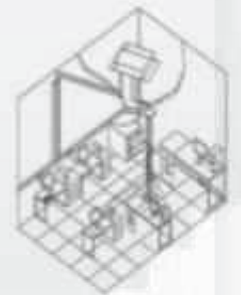

family living room



airport waitina room

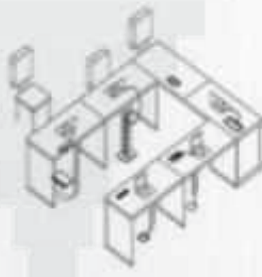

meetina room

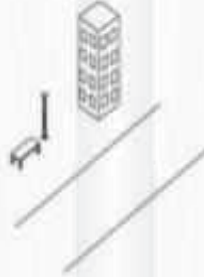

outdoor

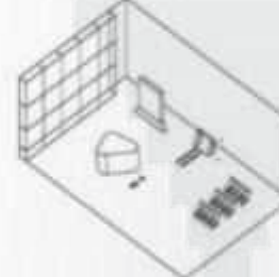

airport

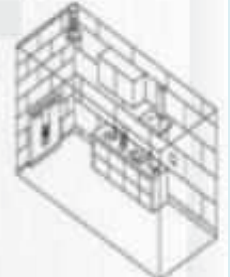

kitchen



PUD: Pop up socket



FZ-517B(Black color)



FZ-517W(whiter color)



FZ-517S(silver color)

FZ-517(B/W/S/G/H):Pop up ,3 socket with 2 damping;

FMD:Flush Mount Desktop



FZ-507S

Alu. Profile for under table



FZ-507B

Plastic Profile for under table



FZ-336

Hidden coverplate with outlets

Industrial socket



HTD-140-1

dia:140mm; Stainless steel



FZ-S66-1

IP68 power painted stainless steel stand pole



HTD-146K/KP-1

*lid:146*146mm square brass*

1.8 Industrial socket IP44 & IP67

IP67 Interlock switch socket



SF1372-4



SF1372

IP44 couper



IP44 Panel mounted socket



SF1431



SF1331



SF1531

IP44 Panel Angle mounted socket



IP44 Wall mounted socket



SF1311



SF1411



SF1411

IP67 couper



SF3322-9



SF3422



SF3522

IP67 Panel mounted socket



SF1332-9



SF1432



SF1532

IP67 Panel Angle mounted socket



SF5332-9



SF5432



SF5532

IP67 Wall mounted socket



SF1312



SF1412



SF1512

IP44 socket



SFS123



SFS123



SFS123

IP67 420A Large current sockets



SF4432

IP67 250A Large current sockets



SF2432

IP44 Low pressure sockets



SFD3231



SFD3331



SFD3232



SFD3332

2.6 Industrial plug

IP44 Plugs



SF1301



SF1401



SF1501

IP44 Wall mounted plug



SF1361



SF1461



SF1561

IP44 Concealed Plug



SF1351



SF1451



SF1551

IP67 Plugs



SF1302



SF1402



SF1502

IP67 Wall mounted plug



SF1362



SF1462



SF1562

IP67 Panel mounted plug



SF1352



SF1452



SF1552

IP44 Plugs

IP67 250A Large current plug

IP67 420A Large current plug



SFS120



SF2402



SF4402

IP44 Low pressure plugs



SFD1301



SFD1201



SFD1302



SFD1202

3.3 Quick connectors

Quick wire connectors

Electrical parameters: 400V/24A & 600V/20A ; Material: PC &PA66



FC773-102



FC773-106



FC773-108



FC773-253



FC773-255

Electrical parameters: 400V/32A; Material : PA66



FC221-414



FC221-415



FC222-413



FC222-414



FC222-415

Electrical parameters: 600V/32A;Material:PA66



FC223-3P



FC223-12P



FC121



FC426

Electrical parameters: 250V/32A; Material; PA66



MC 4 Connectors DC Voltage 1500 V-1800V 30Amps



Electric Vehicle and Electric Vehicle Charging Connectors, Cable Harness

AC EV Charger Connector



Type 1 EV Plug (SAE J1772)

Type 2 Female EV Plug

Type 2 Male EV Plug

AC EV Charger Socket



Type 1 EV Socket

Type 2 Female EV Socket

Type 2 Male EV Socket

DC EV Charger Connector



CCS Combo 1 EV Plug

CCS Combo 2 EV Plug

CHAdeMO EV Plug

DC EV Charger Socket



CCS Combo 1 Inlet Socket

CCS Combo 2 Inlet Socket

CHAdeMO Inlet Socket



(EVA-American Standards EV Plug / Type 1 EV Plug With EV Cable)



(EV-European Standards Female EV Plug / Type 2 Female EV Plug With EV Cable)



(EVFM-European Standards Female to Male EV Plug / Type 2 to Type 2 EV Charging Cable)



(EVAE-American Standards to European Standards EV Plug / Type 1 to Type 2 EV Charging Cable)



GBT DC Charger Connector



GBT DC Charger Socket

Product Introduction:

EV cable is a kind of flexible cable to connect electric vehicle with charging pile or power socket, high quality oxygen-free copper conductor ensures excellent conductor effect, TPE insulation material is soft and high strength, cable sheath is made from high-performance TPE, which possess characteristic as weatherability, high/low temperature resistance, rub resistance, ect. The cable is soft, elastic, flex index and wear-resistant in low temperature. EV Cables for Electric vehicle conductive charging system are fit for Battery Electric Vehicle, Fuel Cell Vehicle(FV) & Hybrid Electric Vehicle(HEV). They are widely used in charging connection between electric vehicle and power supply, or used in Electric Vehicle charging facility & Charge interface.



AC EV Charging Cable

DC Fast Charger Cable

AC Single Phase (1UV)	Conductor	Rated Amp	Rated Voltage	Color
3x2.5mm ² + 2x0.5mm ²	16Amp	450V/750V	Black Orange Green	
3x6.0mm ² + 2x0.5mm ²	32Amp			
3x8.0mm ² + 2x0.5mm ²	40Amp			
3x10mm ² + 2x0.5mm ²	63Amp			
AC Single Phase (3UL)	Conductor	Rated Amp	Rated Voltage	Color
3x14AWG + 1x18AWG	16Amp	600V	Black Orange Green	
3x10AWG + 1x18AWG	32Amp			
2x8AWG + 1x10AWG + 1x16AWG	40Amp			
2x8AWG + 1x10AWG + 1x16AWG	50Amp			
AC Three Phase (1UV)	Conductor	Rated Amp	Rated Voltage	Color
5x2.5mm ² + 2x0.5mm ²	16Amp	450/750V	Black Orange Green	
5x6.0mm ² + 2x0.5mm ²	32Amp			
5x10mm ² + 2x0.5mm ²	63Amp			
5x13.3mm ² + 2x0.5mm ²	70Amp			
DC Fast Charger (1UV)	Conductor	Rated Amp	Rated Voltage	Color
2x16mm ² + 1x2.5mm ² + 6x0.75mm ²	80Amp	750V/1000V	Black Orange Green	
2x35mm ² + 1x2.5mm ² + 6x0.75mm ²	135Amp			
2x50mm ² + 1x2.5mm ² + 6x0.75mm ²	16Amp			
2x70mm ² + 1x2.5mm ² + 6x0.75mm ²	32Amp			



Product Description:

- Conductor: Soft annealed stranded Bare Copper
- Insulation: 125°C halogen free TPE or TPU
- Filler: Cotton thread
- Cover: Non-woven fabrics
- Sheath: 125°C halogen free TPE or TPU
- Color: Black, Orange, Green
- Rated Voltage: AC 450/750V, DC 1000V
- Rated temperature: -25°C upto +125°C
- Voltage Test: 2.5KV AC /15min. No Breakdown
- Short circuit using temperature: +200°C 5s
- Crush Resistance: 5kN, 8kN/h, 220KPa, No Breakdown
- Flame Test: VW-1 test method comply with UL 2556

You are in Right Hand We are Right Partner For You
Genuine and Professional DEAL

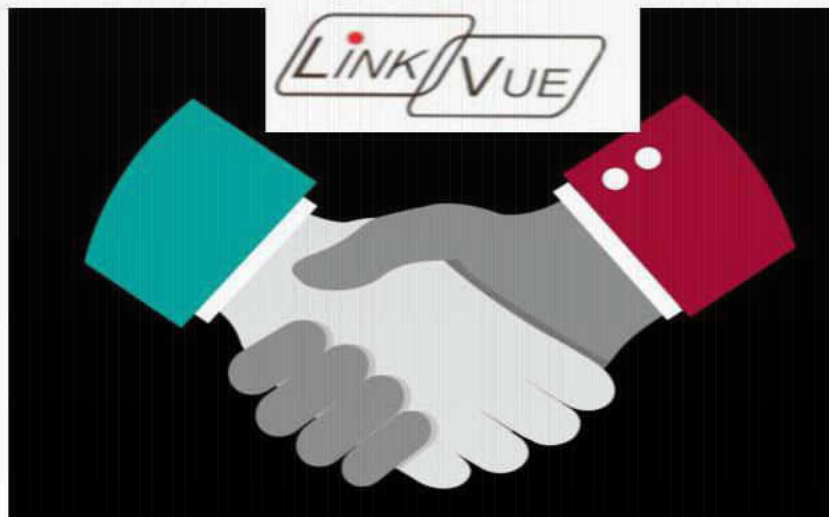



Director:- Mr. Manish Khatri

Head Marketing & Sales:- Mr. Mahesh Chandra Manav

•India

Link Vue System Pvt Ltd

Head Office: I-19, Karampura, New Moti Nagar, New Delhi, (India).

Mobile: +91-9811247237

Tel: +91 11 45597781

[Email:manav.chandra@linkvuesystem.com](mailto:manav.chandra@linkvuesystem.com)

[Email:manish@linkvuesystem.com](mailto:manish@linkvuesystem.com) Website: www.linkvuesystem.com

•Australia Sydney

Link Vue Systems Pty Ltd

2 BRUCE STREET, BLACKTOWN NSW 2148,

Sydney, Australia Mobile:+61-423064098,

[Email:pawandeep@linkvuesystem.com](mailto:pawandeep@linkvuesystem.com) Mobile: +91-9811247237,

[Email:manav.chandra@linkvuesystem.com](mailto:manav.chandra@linkvuesystem.com)